

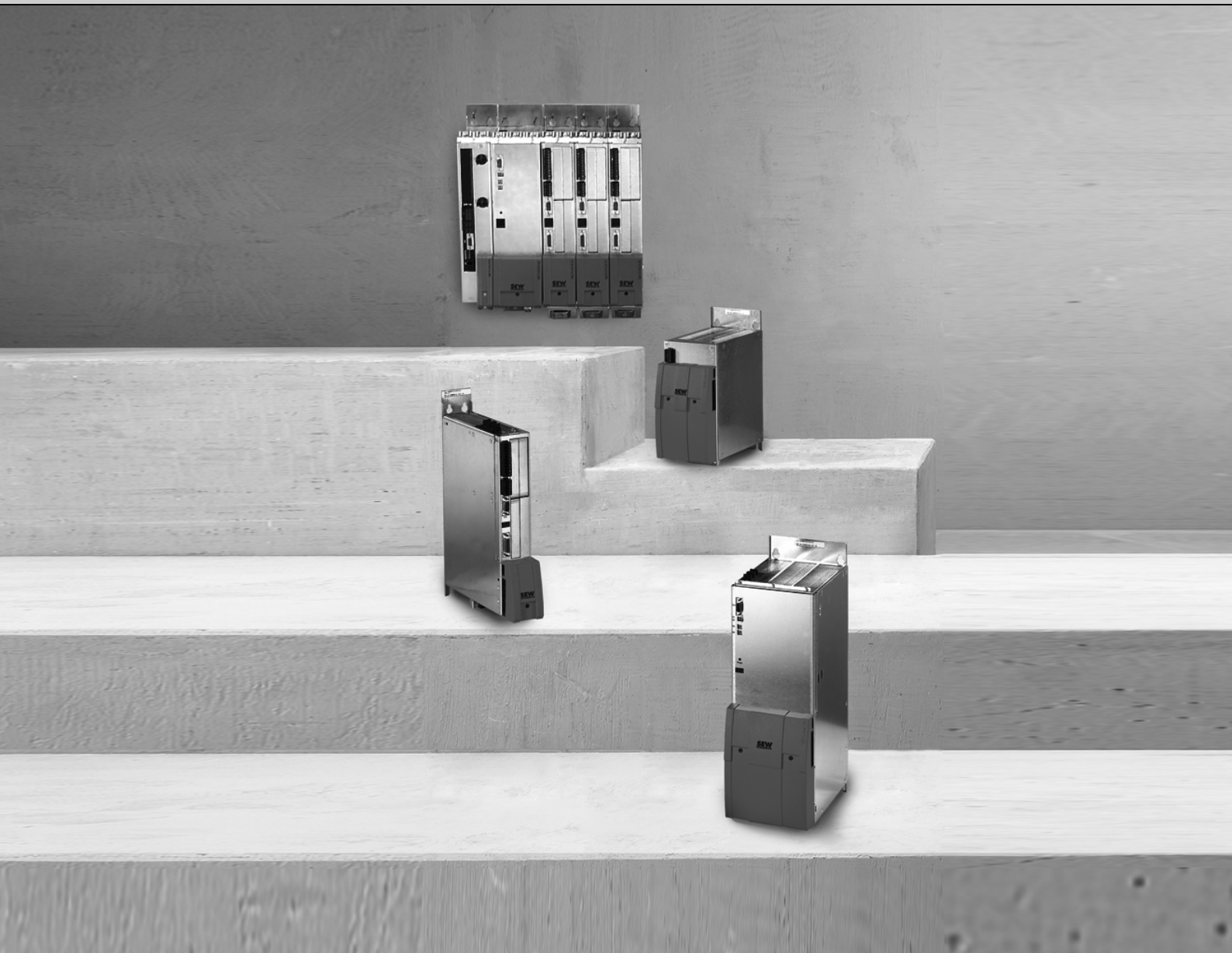

SEW
EURODRIVE

Manual



MOVIAXIS[®] Multi-Axis Servo Inverters Parameter Description





Contents

1	MX Parameter Description	5
1.1	Parameter description for display values	5
1.1.1	Process values of active drive	5
1.1.2	Process values of output stage.....	7
1.1.3	Unit status.....	11
1.1.4	Unit data	14
1.1.5	Unit nameplate.....	17
1.1.6	Error history 0 – 5	18
1.2	Parameter description of drive data	23
1.2.1	Controller parameter P1 / P2 / P3.....	23
1.2.2	Motor parameter P1/P2/P3.....	36
1.2.3	Control functions P1 / P2 / P3.....	41
1.2.4	Limit values P1/P2/P3.....	51
1.2.5	User-defined units P1/P2/P3	54
1.2.6	Reference travel P1/P2/P3	58
1.3	Communication parameter description	73
1.3.1	PDO Editor Process Data Object Editor	73
1.3.2	Basic settings.....	73
1.3.3	IN buffer	81
1.3.4	Control words 0 – 3.....	83
1.3.5	Error message words.....	88
1.3.6	IN process data.....	89
1.3.7	Status words 0 – 3	91
1.3.8	OUT process data.....	98
1.3.9	OUT buffer 0 – 7	100
1.3.10	I/O basic unit.....	104
1.3.11	I/O option 1	104
1.3.12	I/O option 2	107
1.4	Encoder parameter description.....	110
1.4.1	Encoder input of basic unit	110
1.4.2	Position mode settings.....	114
1.4.3	Actual values	115



1.5	Parameter description for FCB parameter setting	120
1.5.1	FCB Function Control Block	120
1.5.2	Basic settings.....	120
1.5.3	FCB 05 Speed control	122
1.5.4	FCB 06 Interpolated speed control.....	125
1.5.5	FCB 07 Torque control	131
1.5.6	FCB 08 Interpolated torque control.....	132
1.5.7	FCB 09 Positioning	134
1.5.8	FCB 10 Interpolated positioning	142
1.5.9	FCB 12 Reference travel	144
1.5.10	FCB 18 Encoder adjustment.....	145
1.5.11	FCB 20 Jog mode.....	153
1.5.12	FCB 21 Brake test	155
1.5.13	FCB 22 Multi-drive.....	159
1.5.14	FCB 25 Rotor position identification	165
1.5.15	FCB 26 Stop at user limits	170
1.6	Parameter description for unit functions	172
1.6.1	Setup	172
1.6.2	Output stage error response.....	175
1.6.3	Reset behavior.....	181
2	MXR Parameter Description	182
2.1	Parameter description for display values	182
2.1.1	Process values output stage.....	182
2.1.2	Unit status.....	183
2.1.3	Unit data	183
2.1.4	Unit nameplate.....	183
2.1.5	Error history	184
2.1.6	Line process values	184
2.2	Parameter description of system data	184
2.2.1	Startup	184
2.2.2	Controller parameters	185
2.2.3	Basic settings.....	186
2.3	Communication parameter description	186
2.3.1	Control word CAN1 / CAN2 / communication options	186
2.3.2	Status word CAN1 / CAN2 / communication options.....	187
2.4	Parameter description for unit functions	189
2.4.1	Setup	189
2.4.2	Reset behavior.....	189
	Index.....	190

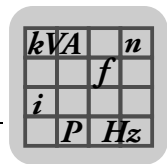

1 MX Parameter Description

The index contains a list with parameters sorted in ascending index order with references to the pages with the relevant parameter description.

Default values are underlined.

1.1 Parameter description for display values

1.1.1 Process values of active drive

- 10120.1 Velocity** Unit: User-defined unit (default: rpm)
Resolution: 10^{-3}
Value range: -2147483648 – 0 – 2147483647, step 1
Current actual velocity in user-defined units.
- 9704.1 Position** Unit: User-defined unit (default: rev)
Resolution: 1/65536
Value range: -2147483648 – 0 – 2147483647, step 1
Current actual position in user-defined units.
- 9839.1 Modulo position** Unit: User-defined unit (default: rev)
Resolution: 1/65536
Value range: -2147483648 – 0 – 2147483647, step 1
Current actual modulo position in user-defined units with the set modulo limits:
- *Parameter 9594.10 modulo overflow* (page 53),
 - *Parameter 9594.1 modulo underflow"* (page 54).
- 9985.1 Torque** Unit: User-defined unit (default: % nominal motor torque)
Resolution: 10^{-3}
Value range: -2147483648 – 0 – 2147483647, step 1
Current torque in user-defined units.
- 9980.1 Speed** Unit: 1/min
Resolution: 10^{-3}
Value range: -2147483648 – 0 – 2147483647, step 1
Current actual speed (system unit).
- 10068.1 Position** Unit: Increments
Resolution: 1/65536
Value range: -2147483648 – 0 – 2147483647, step 1
Current actual position in increments (system unit).

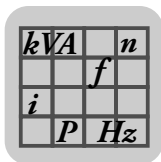

MX Parameter Description

Parameter description for display values

9784.1 Torque

Unit: % nominal motor torque

Resolution: 10^{-3}

Value range: -2147483648 – 0 – 2147483647, step 1

Current motor torque (system unit).

9951.1 Effective minimum torque

Unit: %

Resolution: 10^{-3}

Value range: -2147483648 – 0 – 2147483647, step 1

Effective minimum torque (system unit).

This parameter indicates the currently effective negative torque limit. This limit can be

- the system limit,
- the application limit,
- the current limit,
- one of the FCB limits,
- or a thermal limit of the axis module (I×t model)

depending on which limit would apply first.

9951.2 Effective maximum torque

Unit: %

Resolution: 10^{-3}

Value range: -2147483648 – 0 – 2147483647, step 1

Effective maximum torque (system unit).

This parameter indicates the currently effective positive torque limit. This limit can be

- the system limit,
- the application limit,
- the current limit,
- one of the FCB limits,
- or a thermal limit of the axis module (I×t model)

depending on which limit would apply first.

9872.255 KTY temperature motor

Unit: °C

Resolution: 10^{-3}

KTY motor temperature of the current parameter set.

This is the temperature of the sensor, which may deviate from the motor temperature depending on the dynamics.

Remedy: Motor utilization with calculated motor model.

The KTY sensor has a tolerance of $\pm 5\%$.

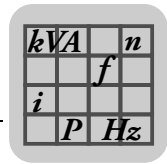

9874.255 Motor utilization, maximum KTY model

Unit: %

Resolution: 10⁻³

Motor utilization of the current parameter set.

The motor utilization uses a motor model to calculate the temperature transition of the motor to the KTY sensor. The injected current is also taken into account. The display is output in % and starts at a motor model temperature of 40 °C = 0% and a shutdown temperature = 100%.

1.1.2 Process values of output stage

MOVIAXIS® monitors a number of internal values to prevent overloading in the axis module. These values include

- Chip hub
- Chip temperature
- Heat sink temperature
- Load on electromechanics

The customer benefits lie in the predictable behavior of MOVIAXIS®, which for example, prevents unwanted or unexpected machine failure and ensures reproducible behavior.

9793.1 Output frequency

Unit: Hz

Resolution: 10⁻³

Displays the current output frequency to the motor in Hz.

9786.1 Output current

Unit: % nominal axis current

Resolution: 10⁻³

Displays the present output current in % of the nominal axis current.

9787.1 Torque current

Unit: % nominal axis current

Resolution: 10⁻³

Displays the torque-generating Q current in % of the nominal axis current.

9788.1 Magnetization current

Unit: % nominal axis current

Resolution: 10⁻³

Displays the magnetization-generating D current in % of the nominal axis current.

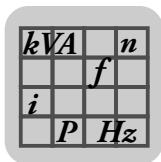

MX Parameter Description

Parameter description for display values

<i>8326.0 Output current</i>	Unit: A Resolution: 10^{-3} Displays the current output current in A (output current).
<i>9853.1 Torque current</i>	Unit: A Resolution: 10^{-3} Displays the torque-generating Q current in A.
<i>9855.1 Magnetization current</i>	Unit: A Resolution: 10^{-3} Displays the magnetization-generating D current in A.
<i>8325.0 DC link voltage</i>	Unit: V Resolution: 10^{-3} Displays the actual DC link voltage in V.
<i>9706.1 Output voltage</i>	Unit: V Resolution: 10^{-3} Displays the current output voltage in V.
<i>9791.1 Torque voltage</i>	Unit: V Resolution: 10^{-3} Displays the torque-generating Q voltage in V.
<i>9792.1 Magnetization voltage</i>	Unit: V Resolution: 10^{-3} Displays the magnetization-generating D voltage in V.
<i>9859.1 Thermal current limit</i>	Unit: % nominal axis current Resolution: 10^{-3} Displays the current thermal current limit in % of the nominal axis current. The axis has a brief overload capacity up to this maximum limit (maximum operating point). The thermal current limit is dynamically adjusted according to the utilization of the axis. It starts at 250% and becomes smaller depending on the utilization.

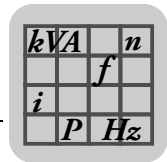

9811.5 Total utilization

Unit: %

Resolution: 10⁻³

Total utilization of the axis in percent.

The highest value of the 4 utilization calculations

- Chip rise,
- Chip absolute,
- Heat sink,
- And electromechanics

is displayed.

The axis trips at 100%.

The parameter is filtered for display because utilization can change very dynamically in particular for the chip.

9811.1 Dynamic utilization chip rise

Unit: %

Resolution: 10⁻³

Dynamic utilization of the chip rise in percent (I×t utilization).

The parameter is unfiltered.

9811.2 Dynamic utilization chip absolute

Unit: %

Resolution: 10⁻³

Absolute dynamic utilization of the chip in percent (I×t utilization).

The parameter is unfiltered.

9811.4 Heat sink utilization

Unit: %

Resolution: 10⁻³

Heat sink utilization in percent (I×t utilization).

The parameter is unfiltered.

9795.1 Heat sink temperature

Unit: °C

Resolution: 10⁻³

Temperature of the heat sink in °C.

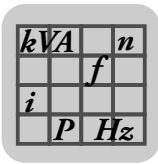

MX Parameter Description

Parameter description for display values

9811.3 *Electro-mechanical utilization*

Unit: %

Resolution: 10^{-3}

Electromechanical utilization in percent (I×t utilization).

The parameter is unfiltered.

8328.0 *ON hours*

Unit: h

Resolution: 10^{-2}

The ON hours are recorded every minute as long as the 24 V control voltage is present and then stored in a non-volatile memory. The quantification in minutes means that a maximum of one minute of ON hours can be lost in case the unit is switched off or rebooted as error acknowledgement.

The value is displayed in hours with 2 decimal places. The ON hours are reset via the parameter *8596.0 Reset statistics data* or *9727.3 Delivery status*.

When an axis error occurs, the ON hours are written to the error memory (see error memory parameters) to better diagnose the time at which the error occurred.

For more thorough SEW internal diagnostics, there is an additional ON hours counter that cannot be reset.

8329.0 *Enable hours*

Unit: h

Resolution: 10^{-2}

In contrast to the ON hours, the enable hours are counted only when the output stage is active. This is based on the status parameter *9702.1 Bit 0 output stage enabled*.

The enable hours are recorded every minute and stored in a non-volatile memory. The quantification in minutes means that a maximum of one minute of enable hours can be lost in case the unit is switched off or rebooted as error acknowledgement.

The value is displayed in hours with 2 decimal places. The enable hours are reset via the parameter *8596.0 Reset statistics data* or *9727.3 Delivery status*.

When an axis error occurs, the enable hours are written to the error memory (see *error memory* parameters) to better diagnose the time at which the error occurred.

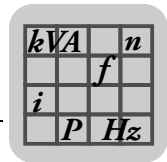

1.1.3 Unit status

- 9702.2 Axis status** Value range:
- 0 = Not ready
 - 1 = Ready, output stage inhibited
 - 2 = Ready, output stage enabled
- Displays axis status.
- 9702.3 Current FCB** Displays currently active FCB.
- 9702.6 Current FCB instance** Displays the currently active FCB instance.
The following FCBs offer more than one instance:
- FCB09 Positioning (64 instances)
 - FCB05 Speed control
 - FCB Torque control
- 9702.4 Active parameter set** Displays current parameter set 1 – 3.
- 9873.1 Active factory setting** Value range:
- 0 = No factory setting (cannot be selected via parameter tree)
 - 1 = Basic initialization
 - 2 = Delivery state
 - 3 = Factory setting
 - 4 = Customer set 1
 - 5 = Customer set 2
- This parameter indicates whether and what type of initialization is currently active.
For a description of the individual initialization options, see section "Unit Functions / Setup" (page 172).
- 9702.1 Status display**
- Bit 0 Output stage enabled
"Output stage enabled" is a subset of "Ready for operation" which is set to "1" in all FCBs except for *FCB 01 Output stage inhibit*.
 - Bit 1 Ready
0 signal: The axis is currently not ready for operation. Reasons can be error states or operating states outside FCB processing (supply voltage off, supply module not ready). All errors are "locked" in the final state.
1 signal: The axis is in FCB processing. If no FCB is selected, the default *FCB 13 Stop at application limits* will become active. The 7-segment display will show the number "13". All errors are "locked" in the final state. See also the operating instructions "MOVIAXIS® MX Multi-Axis Servo Inverters", chapter "Operating Displays and Errors".

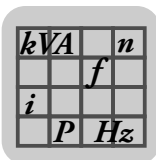

MX Parameter Description

Parameter description for display values

- Bit 2 Setpoints active
This signal is active in all setpoint processing FCBs when setpoints are being processed. This is FCB 05 – FCB 10. The signal is set to "0" in all stop FCBs as well as in the default FCB.
The signal is still 0 during the brake release time.
- Bit 5 Error response display only
This signal is a subset of "Fault" and displays error responses that are configured to "Display fault". The drive continues to operate normally.
- Bit 6 Error response is not equal to output stage inhibit
This signal is a subset of "Fault" and indicates that the drive can be decelerated using a ramp (motor does not coast to a halt / mechanical brake is not applied). This bit is also set when "Signal displayed error".
- Bit 7 Error response output stage inhibit
This signal is a subset of "Fault" and indicates that the motor coasts to a halt or, if installed, the mechanical brake is applied.
- Bit 8 24 V standby mode
Is set when the power supply is removed.
The threshold for this is a parameterizable DC link voltage. See parameter 9617.7 *DC link voltage - one level default* ff.
- Bit 9 Supply module not ready for operation.
If the supply module does not send a ready signal, e.g. due to brake resistor overload or supply system undervoltage.
- Bit 10 Axis module not ready
This parameter is a subset of "Bit 1 Ready" and refers only to the axis module.
- Bit 11 Safe stop 1
Indicates whether a safety relay 1 has detected a safe stop. Only active in conjunction with optional safety relays (device type MXA81A - or MXA82A -..).
- Bit 12 Safe stop 2
Indicates whether a safety relay 2 has detected a safe stop. Only active in conjunction with two optional safety relays (MXA82A -..).
- Bit 13 Process data not ready "C3"
Is displayed when one of the 16 "In buffers" is set to communication and the corresponding PDO has never been received. This signal is not generated any longer once the PDO was received once. Instead, a timeout error is generated when the communication is disconnected.
- Bit 19 Encoder not ready
Displays whether the encoder is communicating. No communication means the encoder or wiring might be defective or that motor startup was not executed.
- Bit 20 Parameter download active
Indicates whether parameters are currently being downloaded.

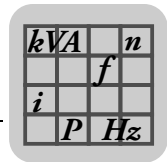

- Bit 22 Synchronization missing
If a synchronization source is set in parameter 9836.1 *Synchronization source*, but the synchronization signal has not been received yet after a reboot.
- Bit 30 Line voltage on
Shows whether the supply voltage is present at the supply module.
 - Line voltage present = TRUE
 - Line voltage not present = FALSE
 You can parameterize how fast a power failure is detected. See parameter 9746.1 *Power off response*.
- Bit 31 Line voltage off
Shows whether the supply voltage is present at the supply module.
 - Line voltage present = FALSE
 - Line voltage not present = TRUE
 You can parameterize how fast a power failure is detected. See parameter 9746.1 *Power off response*.

- 9950.1 *Error end status* Displays the currently pending error status:
- Bit 0 Displaying
The axis only displays the error in the 7-segment display. The axis continues to run in normal operation.
 - Bit 1 Waiting
The axis waits for a manual reset. The error is reset and operation is continued without boot reset of the firmware.
 - Bit 2 Locked
The axis waits for a manual reset. The axis then reboots (like when it is switched on).
- 9702.5 *Error code* Displays the pending error code. See also list of faults in the MOVIAXIS® operating instructions.
- 10071.1 *Suberror code* Displays the pending suberror code. See also list of faults in the MOVIAXIS® operating instructions.
- 8617.0 *Manual reset* Value range:
- 0 = No
 - 1 = Yes
- Manual reset to reset the error.

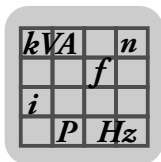

MX Parameter Description

Parameter description for display values

1.1.4 Unit data

<i>9701.1 – 5 Axis type</i>	Displays the order designation of the unit, e.g. MXA-80A-004-503-00.
<i>9701.10 Unit series</i>	Displays the unit series, e.g. MOVIAXIS®.
<i>9701.11 Unit variant</i>	Displays the unit variant.
<i>9701.13 Nominal unit voltage</i>	Unit: mV Value range: 0 – 2000000, step 1 Displays the nominal unit voltage.
<i>9701.14 Number of input phases</i>	Value range: <ul style="list-style-type: none"> • 1 = Single-phase • <u>3 = Three phase</u> Displays the number of input phases.
<i>9701.15 Radio interference suppression on mains end</i>	Value range: <ul style="list-style-type: none"> • <u>1 = none</u> • 2 = A • 3 = B Displays the implemented radio interference suppression compliant with the EMC product standard EN 61800-3.
<i>9617.1 Maximum possible output speed</i>	Unit: 10 ⁻³ /min Value range: 0 – 1000000, step 1 Maximum possible output speed that the axis module can control.
<i>9617.6 Nominal unit current</i>	Unit: mA Value range: 0 – 30000 – 1000000, step 1 Nominal unit current, r.m.s. value.
<i>9617.2 Maximum output current</i>	Unit: mA Value range: 0 – 12000 – 1000000, step 1 Maximum possible output current, r.m.s. value.
<i>9701.17 Standard encoder system</i>	Value range: <ul style="list-style-type: none"> • <u>13 = Hiperface®/resolver</u> Displays the SEW standard encoder for the unit.
<i>9701.18 Unit serial number</i>	Value range: 0 – 4294967295, step 1 Displays the serial number.

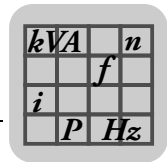

<i>9823.1 – 5 Unit signature</i>	Display and entry of the unit signature. You can assign a name to the device to have it displayed in the hardware tree and the visualization components.
<i>9701.30 Firmware part number basic unit</i>	Displays the firmware part number of the basic unit.
<i>9701.31 Firmware status basic unit</i>	Displays the firmware status of the basic unit.
<i>9701.32 Firmware version number basic unit</i>	Displays the firmware version number of the basic unit.
<i>9880.3 Initial boot loader part number</i>	Value range: 0 – 4294967295, step 1 Initial boot loader part number.
<i>9880.5 Initial boot loader status</i>	Value range: 0 – 4294967295, step 1 Initial boot loader status.
<i>9881.3 Boot loader part number</i>	Value range: 0 – 4294967295, step 1 Bootloader part number.
<i>9881.5 Boot loader status</i>	Value range: 0 – 4294967295, step 1 Boot loader status.
<i>9701.33 DSP firmware part number</i>	Value range: 0 – 4294967295, step 1 DSP firmware part number.
<i>9701.34 DSP firmware status</i>	Value range: 0 – 4294967295, step 1 DSP firmware status.
<i>9701.35 DSP firmware version number</i>	Value range: 0 – 4294967295, step 1 DSP firmware version number.
<i>9701.37 FPGA status</i>	Value range: 0 – 4294967295, step 1 FPGA firmware status.
<i>9701.38 FPGA status</i>	Value range: 0 – 4294967295, step 1 FPGA firmware status.

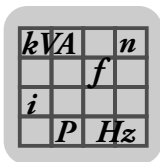

MX Parameter Description

Parameter description for display values

9701.41 <i>Signal electronics</i>	Value range: 0 – 4294967295, step 1 Hardware status (computer card).
9701.50 <i>Option in slot 1</i>	Value range: <ul style="list-style-type: none"> • 0 = No option • 1 = Unknown option • 2 = XIO11A (Digital I/O) • 3 = XIA11A (Analog-Digital I/O) • 4 = XHE41A (Plug-in control) • 5 = XHC41A (Plug-in control) • 6 = XHA41A (Plug-in control) • 7 = XGS11A (Multi-encoder card) • 8 = XGH11A (Multi-encoder card) • 9 = XFE24A (EtherCAT card) • 13 = XFA11A (K-Net)
9701.60 <i>Option in slot 2</i>	Value range: See parameter 9701.50 "Option in slot 1" (page 16).
9701.70 <i>Option in slot 3</i>	Value range: See parameter 9701.50 "Option in slot 1" (page 16).
9701.53 <i>Option in slot 1, firmware part number</i>	Displays firmware part number of option 1.
9701.63 <i>Option in slot 2, firmware part number</i>	Displays firmware part number of option 2.
9701.73 <i>Option in slot 3, firmware part number</i>	Displays firmware part number of option 3.
9701.54 <i>Option in slot 1, firmware status</i>	Displays firmware status of option 1.
9701.64 <i>Option in slot 2, firmware status</i>	Displays firmware status of option 2.
9701.74 <i>Option in slot 3, firmware status</i>	Displays firmware status of option 3.

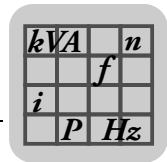

1.1.5 Unit nameplate

The electronic motor nameplate with the corresponding motor data is supported.

- 9701.110 *Status 1* Delivery state unit status field 1: Unit firmware.
- 9701.111 *Status 2* Delivery state unit status field 2: FPGA/DSP firmware.
- 9701.113 *Status 4* Delivery state unit status field 4: Control electronics.
- 9701.114 *Status 5* Delivery state unit status field 5: Power section.
- 9701.115 *Status 6* Delivery state unit status field 6: Switched-mode power supply.
- 9701.116 *Status 7* Delivery state unit status field 7: Attenuation.
- 9701.117 *Status 8* Delivery state unit status field 8: Safe technology.
- 9701.118 *Status 9* Delivery state unit status field 9: Reserve.
- 9701.125 *Option 1 software status* Delivery state option 1: Status field 1 software.
- 9701.126 *Option 1 hardware status* Delivery state option 1: Status field 2 hardware.
- 9701.135 *Option 2 software status* Delivery state option 2: Status field 1 software.
- 9701.136 *Option 2 hardware status* Delivery state option 2: Status field 2 hardware.
- 9701.145 *Option 3 software status* Delivery state option 3: Status field 1 software.
- 9701.146 *Option 3 hardware status* Delivery state option 3: Status field 2 hardware.
- 9701.155 *Option 4 software status* Delivery state option 4: Status field 1 software.
- 9701.156 *Option 4 hardware status* Delivery state option 4: Status field 2 hardware.
- 9701.165 *Option 5 software status* Delivery state option 5: Status field 1 software.
- 9701.166 *Option 5 hardware status* Delivery state option 5: Status field 2 hardware.

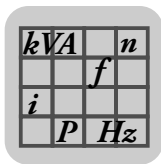

MX Parameter Description

Parameter description for display values

1.1.6 Error history 0 – 5

MOVIAXIS® stores the last 6 error states in a ring memory. A certain number of parameters are "frozen" here. Parameter *9626.1 Pointer to error memory t0 – t5* (page 18) points to the last error saved. Another index range is described each time an error is saved.

The parameter tree adapts the interface so that the error ring memory 0 – 5 is always sorted chronologically. Error ring memory 0 is the last one saved.

Error memory t5 is described below.

<i>9626.1 Error memory pointer</i>	Value range: 0 – 5, step 1 Pointer to error memory t0 – t5.
<i>9628.1 Inputs</i>	Value range: 0 – 4294967295, step 1 Displays binary inputs of basic unit t5.
<i>9630.1 Outputs</i>	Value range: 0 – 4294967295, step 1 Displays binary outputs of basic unit t5.
<i>9629.1 Inputs</i>	Value range: 0 – 4294967295, step 1 Displays binary inputs of option 1 t5.
<i>9631.1 Outputs</i>	Value range: 0 – 4294967295, step 1 Displays binary outputs option 1 t5.
<i>9629.2 Inputs</i>	Value range: 0 – 4294967295, step 1 Displays binary inputs of option 2 t5.
<i>9631.2 Outputs</i>	Value range: 0 – 4294967295, step 1 Displays binary outputs option 2 t5.
<i>9508.1 Resolution</i>	Value range: 0 – 4294967295, step 1 User-defined unit position resolution t5.
<i>9509.10 Denominator</i>	Value range: 0 – 4294967295, step 1 User-defined unit position denominator t5.
<i>9509.1 Numerator</i>	Value range: 0 – 4294967295, step 1 User-defined unit position numerator t5.
<i>9507.50 Position</i>	Value range: 0 – 4294967295, step 1 User-defined unit position t5.
<i>9502.1 Resolution</i>	Value range: 0 – 4294967295, step 1 User-defined unit speed resolution t5.

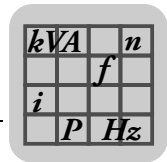

<i>9503.10 Denominator</i>	Value range: 0 – 4294967295, step 1 User-defined unit speed denominator t5.
<i>9503.1 Numerator</i>	Value range: 0 – 4294967295, step 1 User-defined unit speed numerator t5.
<i>9501.50 Velocity</i>	Value range: 0 – 4294967295, step 1 User-defined unit speed characters 0 – 3 t5.
<i>9501.51 Velocity</i>	Value range: 0 – 4294967295, step 1 User-defined unit speed characters 4 – 7 t5.
<i>9501.52 Velocity</i>	Value range: 0 – 4294967295, step 1 User-defined unit speed characters 8 – 11 t5.
<i>9501.53 Velocity</i>	Value range: 0 – 4294967295, step 1 User-defined unit speed characters 12 – 15 t5.
<i>9812.1 Rel.</i>	Unit: % Resolution: 10 ⁻³ Value range: 0 – 300000, step 1 Dynamic utilization relative t5.
<i>9623.1 Abs.</i>	Unit: % Resolution: 10 ⁻³ Value range: 0 – 300000, step 1 Dynamic utilization absolute t5.
<i>10069.1 Model</i>	Unit: % Resolution: 10 ⁻³ Value range: 0 – 300000, step 1 Motor utilization current motor model t5.
<i>9538.1 KTY</i>	Unit: % Resolution: 10 ⁻³ Value range: 0 – 300000, step 1 Motor utilization current motor KTY t5.
<i>9622.1 Heat exchanger</i>	Unit: % Resolution: 10 ⁻³ Value range: 0 – 300000, step 1 Cooling unit utilization t5.

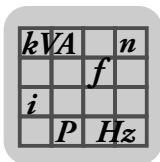

MX Parameter Description

Parameter description for display values

<i>9624.1 Thermal</i>	Unit: % Resolution: 10^{-3} Value range: 0 – 300000, step 1 Thermal utilization t5.
<i>9635.1 Device</i>	Unit: % Resolution: 10^{-3} Value range: 0 – 300000, step 1 Unit utilization t5.
<i>9627.1 Error</i>	Value range: 0 – 99, step 1 Display error code t5.
<i>10072.1 Suberror</i>	Value range: 0 – 32767, step 1 Suberror code t5.
<i>9636.1 DC link voltage</i>	Unit: mV Value range: 0 – 1000000, step 1 DC link voltage t5.
<i>9505.1 Output voltage</i>	Unit: mV Value range: 0 – 1000000, step 1 Output voltage t5.
<i>9500.6 Actual speed</i>	Unit: 10^{-3} /min Value range: -11000000 – 11000000, step 1 Displays actual velocity current parameter set in t5.
<i>10070.1 Model</i>	Unit: °C Resolution: 10^{-3} Value range: -2147483648 – 0 – 2147483647, step 1 Motor temperature current motor model t5.
<i>9545.1 KTY</i>	Unit: °C Resolution: 10^{-3} Value range: -2147483648 – 0 – 2147483647, step 1 Motor temperature current motor KTY t5.

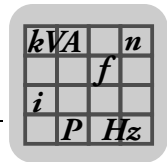

- 9505.30 ON hours** Unit: h
Resolution: 10⁻²
- The ON hours are recorded every minute as long as the 24 V control voltage is present and then stored in a non-volatile memory. The quantification in minutes means that a maximum of one minute of ON hours can be lost in case the unit is switched off or rebooted as error acknowledgement.
- The value is displayed in hours with 2 decimal places. The ON hours are reset via the parameter *8596.0 Reset statistics data* or *9727.3 Delivery status*.
- When an axis error occurs, the ON hours are written to the error memory (see error memory parameter) to better diagnose the time at which the error occurred.
- For more thorough SEW internal diagnostics, there is an additional ON hours counter that cannot be reset.
-
- 9505.40 Enable hours** Unit: h
Resolution: 10⁻²
- In contrast to the ON hours, the enable hours are counted only when the output stage is active. This is based on the status parameter *9702.1 Bit 0 output stage enabled*.
- The enable hours are recorded every minute and stored in a non-volatile memory. The quantification in minutes means that a maximum of one minute of enable hours can be lost in case the unit is switched off or rebooted as error acknowledgement.
- The value is displayed in hours with 2 decimal places. The enable hours are reset via the parameter *8596.0 Reset statistics data* or *9727.3 Delivery status*.
- When an axis error occurs, the enable hours are written to the error memory (see *error memory* parameter) to better diagnose the time at which the error occurred.
-
- 9632.1 Device status** Value range: 0 – 4294967295, step 1
Displays unit status t5.
-
- 9506.6 Actual position** Unit: U
Resolution: 1/65536
Value range: -2147483648 – 0 – 2147483647, step 1
Actual position t5.
-
- 9633.1 Output current** Unit: % nominal axis current
Resolution: 10⁻³
Value range: 0 – 300000, step 1
Output current t5.
-
- 9852.1 Phase failure detection** Value range: see index 8617.0 (page 181).
Line phase failure t5.

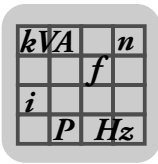

MX Parameter Description

Parameter description for display values

9504.1 *Frequency* Unit: Hz
 Resolution: 10^{-3}
 Value range: 0 – 1000000, step 1
 Frequency t5.

9634.1 *Active current* Unit: % nominal axis current
 Resolution: 10^{-3}
 Value range: 0 – 300000, step 1
 Active current t5.

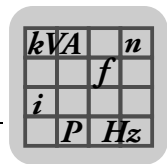

1.2 Parameter description of drive data

	INFORMATION
	Sections and chapters that contain "P1 / P2 / P3" apply to all 3 parameter sets.

MOVIAXIS® operates with the CFC control mode for asynchronous and synchronous motors with encoder feedback. MOVIAXIS® can be operated in the basic control types torque, speed and position control. This means that the customer can activate closed-loop control circuits where they are most suitable for the application. MOVIAXIS® can be implemented in a wide range of applications and, in many cases, can take on all the tasks of a motion controller.

1.2.1 Controller parameter P1 / P2 / P3

8537.0 / 8538.0 /
9720.0 Direction of
rotation reversal

Value range:

- 0 = Off
- 1 = On

Direction of rotation reversal P1.

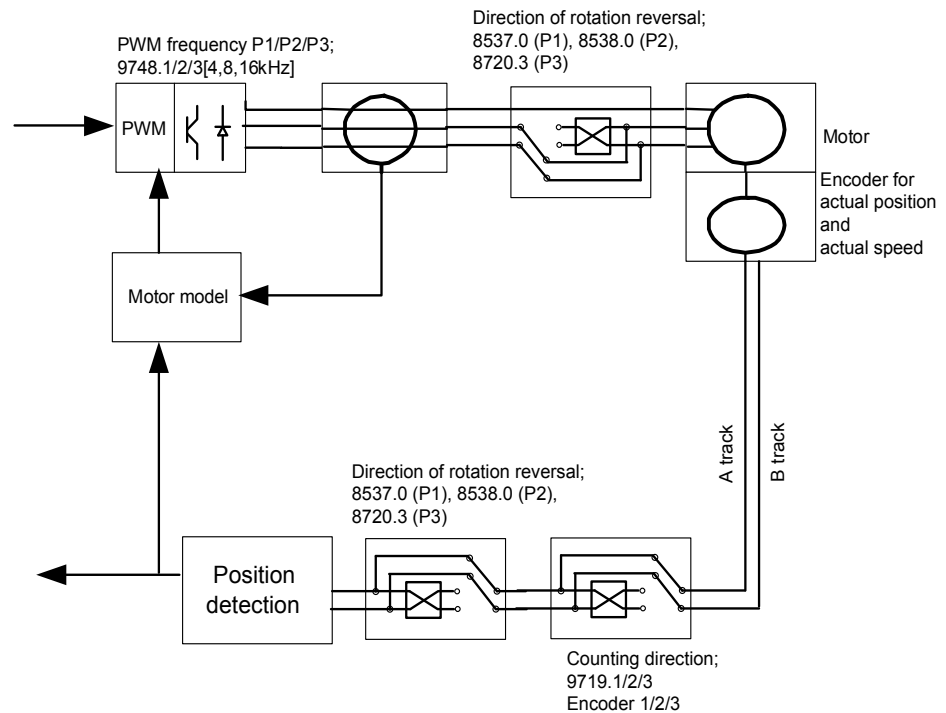

1238107659

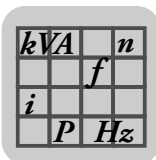

MX Parameter Description

Parameter description of drive data

The SEW-EURODRIVE standard defines that the motor rotates in clockwise direction (right) when the speed is positive and with increasing positions when viewed onto the motor shaft. Reversing the direction of rotation changes the sense of rotation of the motor without having to reverse the setpoint. Activating a reversal of the direction of rotation will invert the direction of rotation of the motor phases and encoder evaluation.

Direction of rotation reversal	Speed setpoint	Direction of rotation motor shaft (looking onto the drive-end bearing shield)	Position	Actual speed value	Actual acceleration value
0=Off; standard	Positive	Clockwise, "right"	Increases	Positive	Derived from the actual speed value
	Negative	Counterclockwise, "left"	Decreases	Negative	Derived from the actual speed value
1=On; inverted	Positive	Counterclockwise, "left"	Increases	Positive	Derived from the actual speed value
	Negative	Clockwise, "right"	Decreases	Negative	Derived from the actual speed value

The assignment of limit switches to the system is maintained.

When using this parameter, it is important to carefully check that the limit switch is connected properly and the reference point and travel positions are defined correctly.

Direction of rotation reversal and limit switch evaluation

Example: **Reversal of direction of rotation 8537.0=0 (off) (page 23)**

When the motor turns in **clockwise** direction, the drive will be properly stopped once it hits the **positive** limit switch. If it reaches the negative limit switch, the drive will respond with error code "27" (limit switches reversed).

Example: **Reversal of direction of rotation 8537.0=1 (ON) (page 23)**

When the motor turns in **counterclockwise** direction, the drive will be properly stopped once it hits the **positive** limit switch. If it reaches the negative limit switch, the drive will respond with error code "27" (limit switches reversed).

Do not mistake the parameter "**Direction of rotation reversal P1; P8537.0 (page 23)**" for the parameter "**Counting direction encoder 1; P9719.1 (page 111)**", see the "Encoders" chapter.

Current controller

9813.1 Activate I×t current reduction

Value range:

- 0 = Off
- 1 = On

The parameter cannot be edited in the parameter tree.

A current limit is set using the parameter setting "On" to ensure reliable operation of the axes even in the case of an overload.

The switch is only implemented in "Controller inhibit active" status.

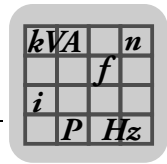

Function	Feature	Consistency
"On" default setting	Current is reduced before heat sink or power semiconductor triggers shutdown. Maximum available current < 250%.	Possibility of compensating load peaks that occur once. Might trigger subsequent errors because the required torque is not delivered any longer (e.g. lag error).
"Off"	Maximum available current = 250%	Immediate shutdown in the event of overload (results in controller inhibit). The entire device performance can be utilized.

9748.1 / 9748.2 /
9748.3 PWM
frequency

Value range:

- 0 = 4 kHz
- 1 = 8 kHz
- 2 = 16 kHz

PWM frequency P1 / P2 / P3

The **PWM frequency** is used to set the switching frequency at the inverter output. The cycle frequency is set to a fixed value and is not automatically reduced with high unit utilization.

A smaller modulation frequency reduces the switching losses in the output stage and, consequently, unit utilization. The motor noise, however, will increase.

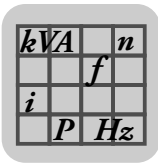

MX Parameter Description

Parameter description of drive data

Control structures The FCBs use different control structures.

The following table gives an overview of control structures activated by the FCBs.

FCB No.	Name	Torque control "MXDrehmomentStromreglerV1_5.vsd"	Speed control	Position control	External profile generation	Internal profile generation
0	No function block selected (starts FCB 13)		X			
1	Controller inhibit	Controller inhibited				
5	Speed control		X			Var1+4
6	Speed control, interpolated		X		Var1+4	
7	Torque control	X				Var 4
8	Torque control, interpolated	X			Var4	
9	Positioning			X		Var2+4
10	Positioning, interpolated			X	Var2+4	
12	Referencing		Referencing	Basic setting		
13	Stop (application limits)		X			Var1+4
14	Stop (emergency stop limit)		X			Var1+4
15	Stop (system limits)		X			Var1+4
16	Electronic cam			X		Var2+4
17	Synchronous operation			X		Var2+4
18	Encoder adjustment	Current control				
19	Hold control		Stop	Hold		
20	Jog			X		Var2+4
21	Brake test	Mode 1		Modes 2-4		
22	Double drive		X			

123811115

The variants "Var 1 - 4" are depicted in the figure "Control structure overview" (page 27).

kVA	n
f	
i	
P	Hz

Control structure overview

The control structure is cascaded (position, speed, current-torque controller). The following diagram shows an overview of the control structures described in detail on the following pages.

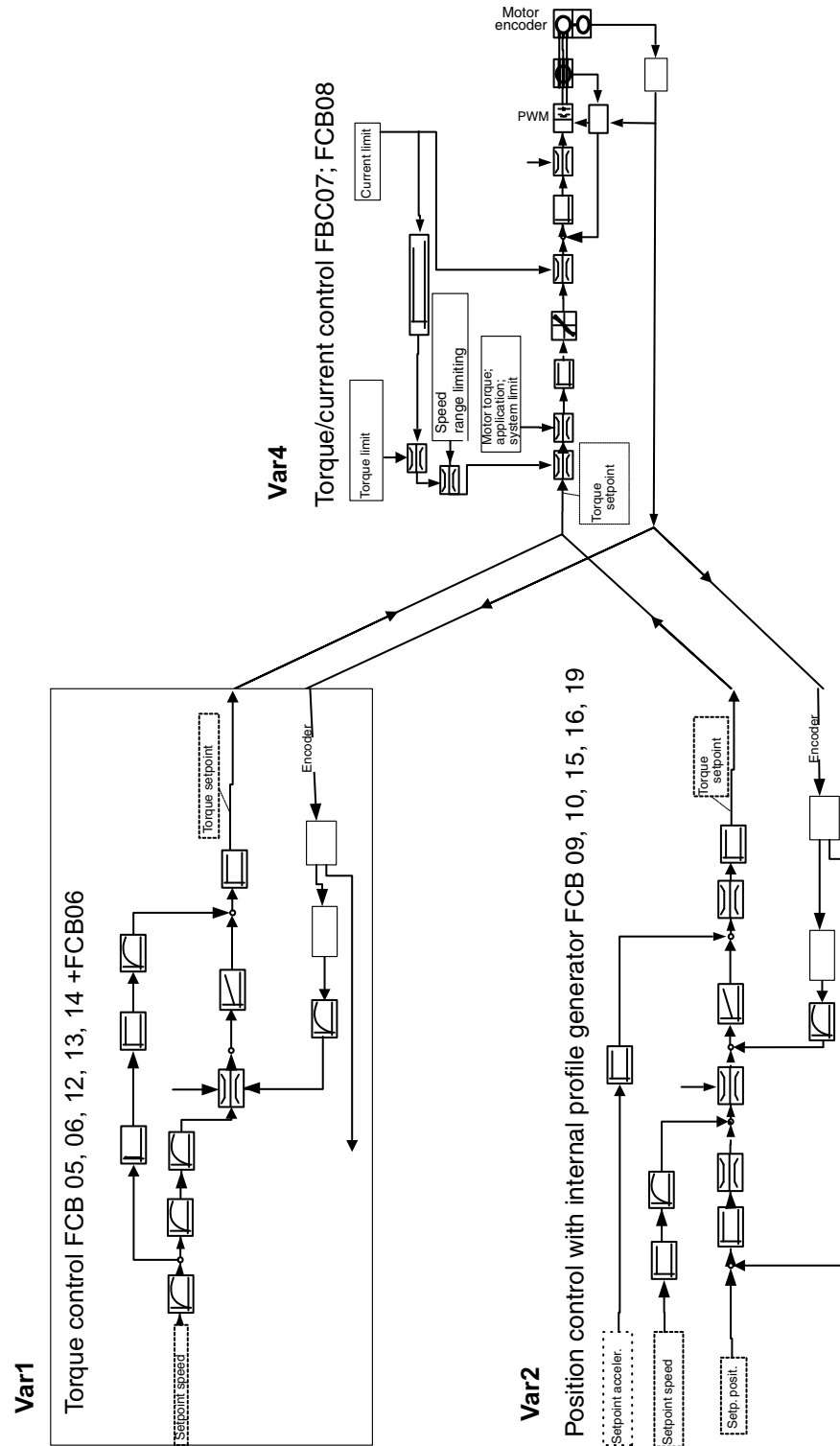

1238830347

See also the control structure table. (page 26)

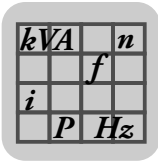

MX Parameter Description

Parameter description of drive data

Speed control FCB 05 (page 122), 06 (page 125), 12 (page 144), 13, 14

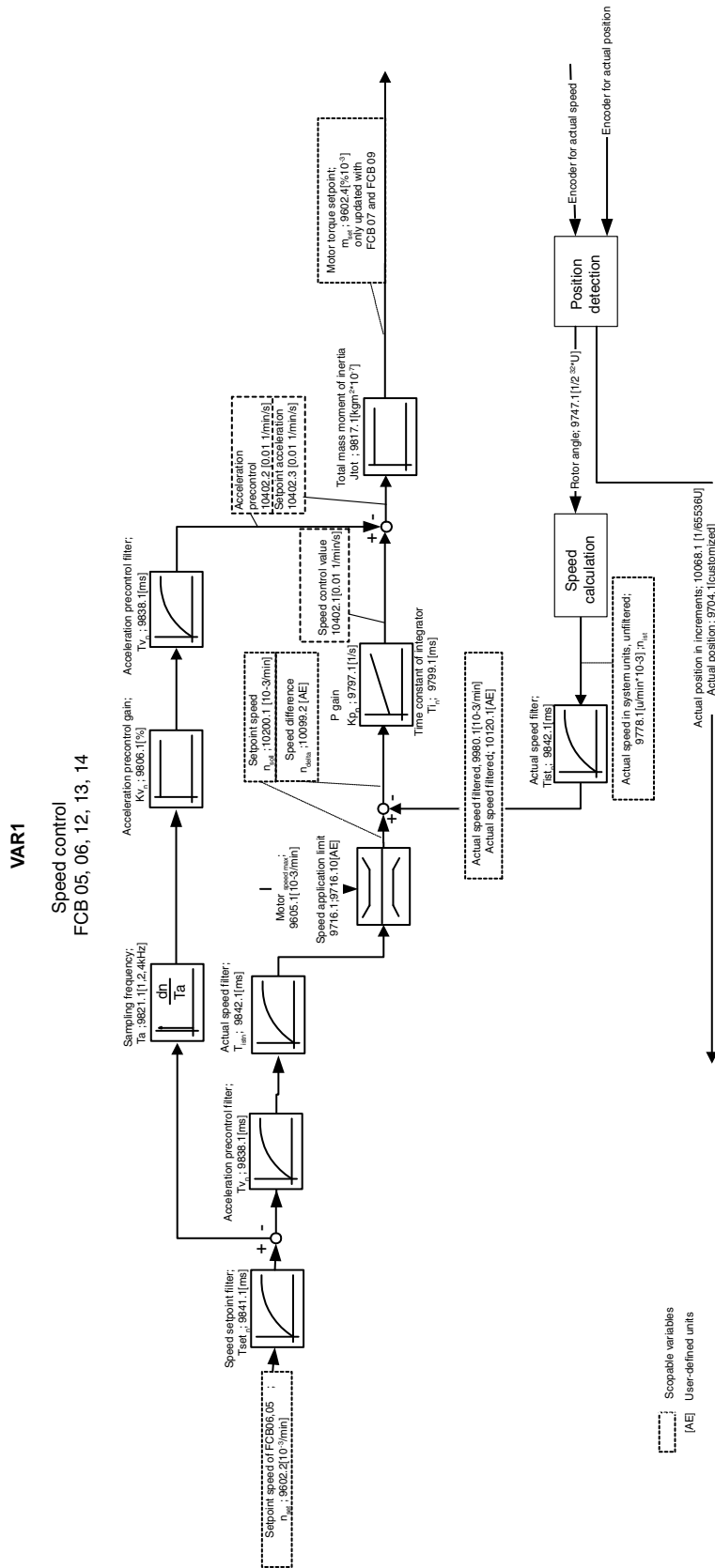

1238832779

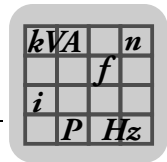

Position control with internal profile generator FCB 09 (page 134), 10 (page 142), 15, 16, 19

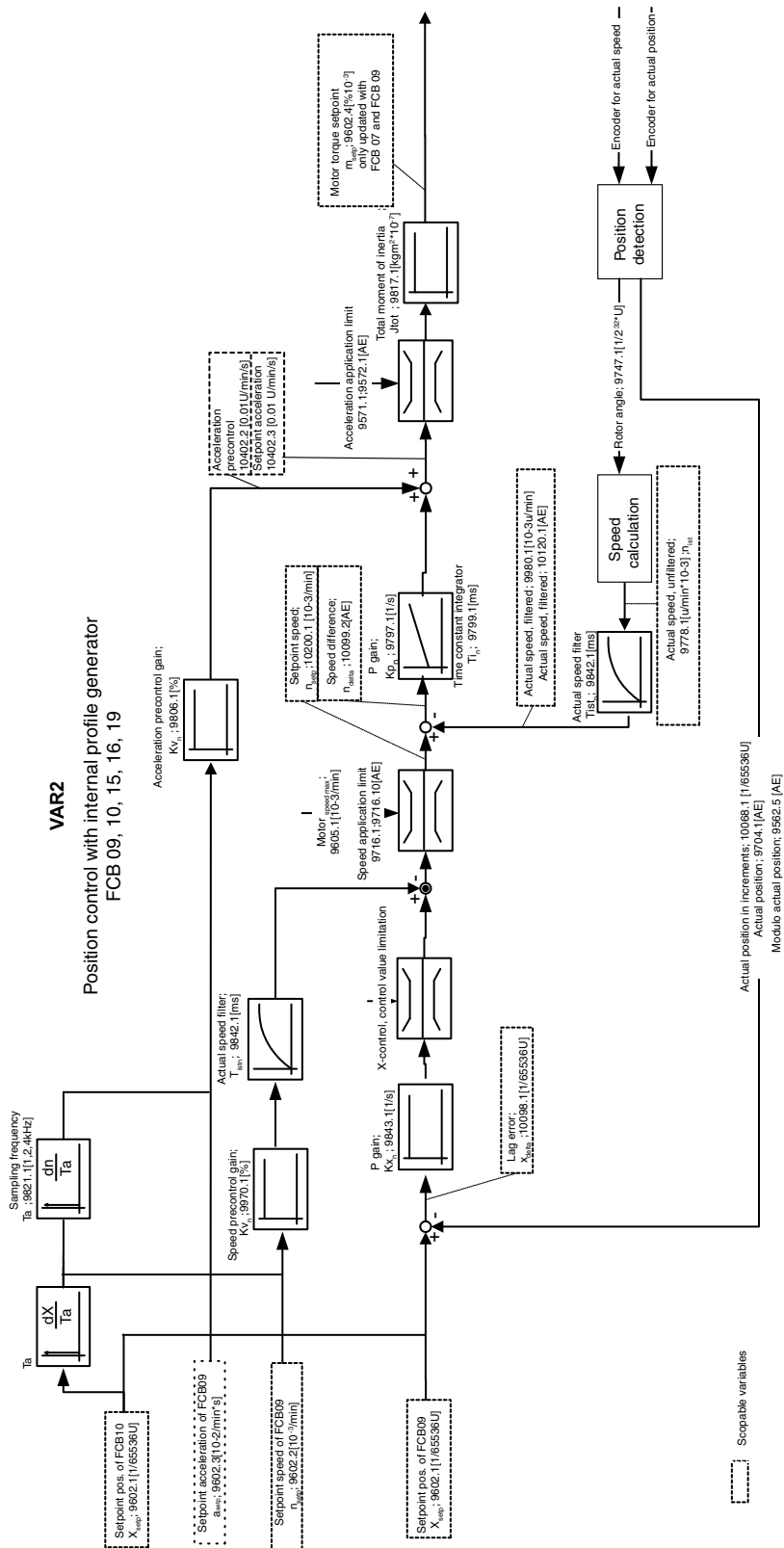

1239532043

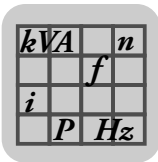

MX Parameter Description

Parameter description of drive data

Torque/current controller

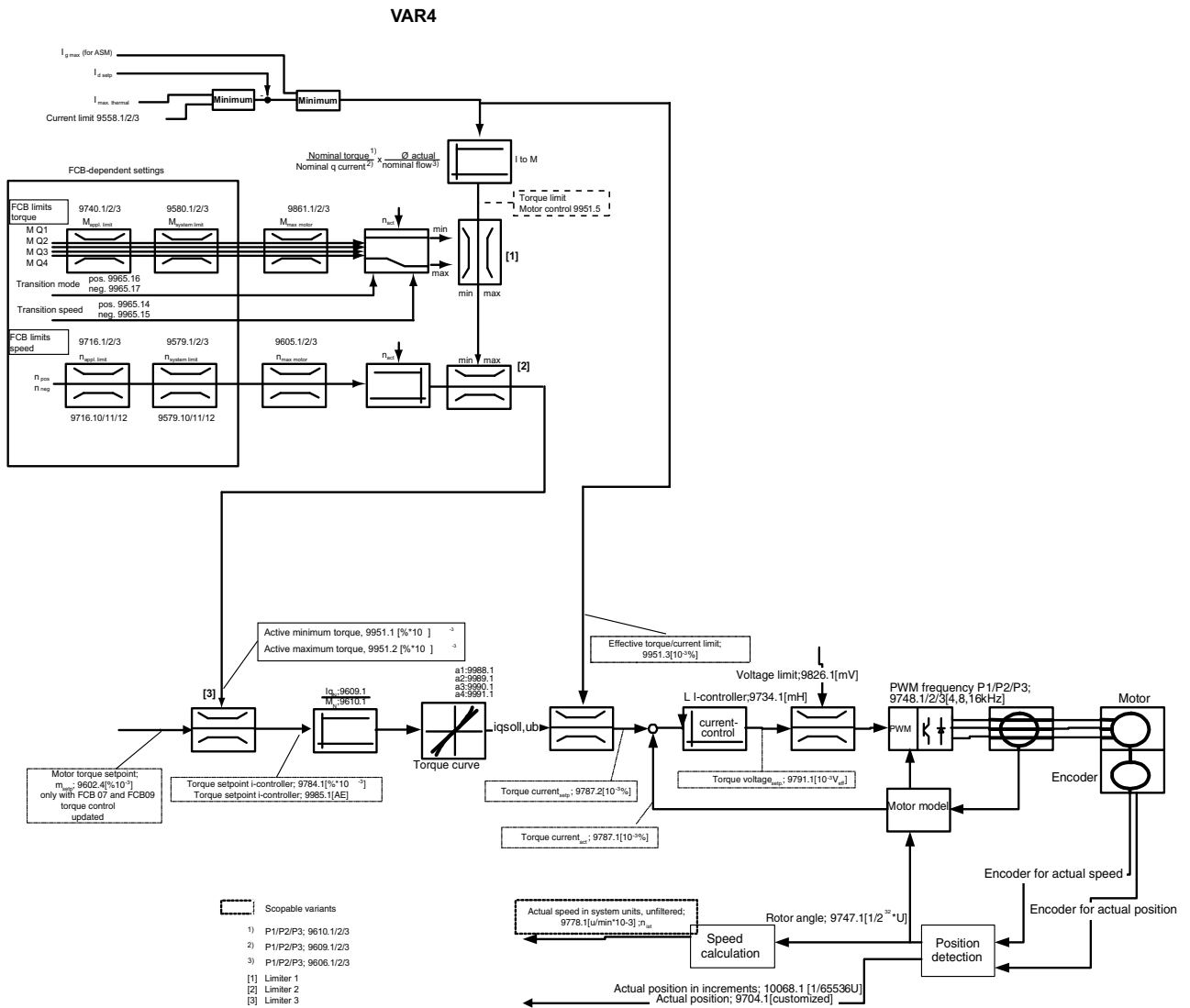

1239636875

Refer to the illustration for limits that are activated.

The relationship between the min/max delimiters 1 – 3 and the specific limit statement is listed in the following table.

Significance "1" means that this delimiter limits the input parameters and sets the limit values to its output. Vice versa with "0".

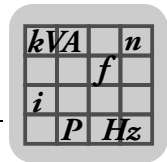

The speed limits are then clearly implemented using the limited torque specifications.

Delimiter 1	Delimiter 2	Delimiter 3	Limitation information
0	0	0	No M_{setp} limit
0	0	1	M_{setp} is limited by the specified speed
0	1	0	No M_{setp} limit
0	1	1	M_{setp} is limited by motor control (max. motor current, $I_{max. thermal}$, current limit, –)
1	0	0	No M_{setp} limit
1	0	1	M_{setp} is limited by the specified speed
1	1	0	No M_{setp} limit
1	1	1	M_{setp} is limited by the torque limit

9734.1 / 9734.2 /
9734.3 LI controller

Unit: H

Resolution: 10^{-7}

Value range: 0 – 214748367, step 1

Branch inductance of the motor.

Is used to set the parameters of the current controller (I controller) (P1/P2/P3). The integrative time and the gain are set using this parameter.

9558.1 / 9558.2 /
9558.3 Current
limit

Unit: mA

Value range: 0 – 2000000, step 1

Current limit P1 / P2 / P3.

The current limit indirectly limits the torque-generating current (Q current), see figure "Torque/current controller" (page 30). This is the only value in MOVIAXIS® that is directly entered in [mA]. All other "current" values refer to the nominal current of the device.

9826.1 / 9826.2 /
9826.3 Voltage
limit

Unit: mV

Value range: 0 – 230000 – 1000000, step 1

Control limit output voltage P1/P2/P3.

The value V_{rms} is the phase unit, the default value is 230 V.

This parameter limits the maximum output voltage, see figure "Torque/current -controller" (page 30).

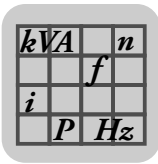

MX Parameter Description

Parameter description of drive data

Scanning frequency

9821.1 / 9821.2 /
9821.3 Scanning
frequency

Value range:

- 0 = 1 ms
- 1 = 0,5 ms
- 2 = 0.25 ms

Scanning frequency n-/X control P1 / P2 /P3

Is used to set the scanning frequency of the speed and position controller.

A high scanning frequency is only needed when the desired dynamic response requires it. This is only needed for drives with fast cycle times (<100 ms positioning time).

A higher scanning frequency results in a rougher actual speed value resolution. This means the scanning frequency should be set to a lower value for applications that require a very even speed.

These effects are more likely to occur in encoder systems with unfavorable resolution. See encoder resolution, chapter "Encoder" (page 110).

With the same stiffness and clearance settings, the scanning frequency has no influence on the gain, integrative time and control technology filter settings that are suggested at startup.

9797.1 / 9797.2 /
9797.3 P-gain

Unit: $10^{-3}/s$

Value range: 0 – 100000 – 10000000, step 1

P-gain N controller P1/P2/P3.

The unit of the gain is chosen in such a way that the velocity difference (speed setpoint/ actual speed value) results in acceleration.

Controller configuration is independent of the used inverter and connected mass moment of inertia because the control operates in SI units (revolution; rpm; rpm/s). Of course, you need to enter the current total mass moment of inertia "9817.1/2/3 (page 35)" to ensure the conversion of acceleration into torque.

9970.1 / 9970.2 /
9970.3 Speed
precontrol gain

Unit: %

Resolution: 10^{-3}

Value range: 0 – 100000 – 10000000, step 1

Velocity precontrol gain P1/P2/P3

100% is the optimum value. This gain multiplies the theoretically calculated velocity precontrol values.

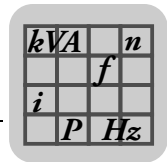

- 9806.1 / 9806.2 /
9806.3 *Acceleration precontrol gain*
- Unit: %
Resolution: 10⁻³
Value range: 0 – 100000 – 10000000, step 1
Acceleration precontrol gain P1/P2/P3.
100% is the optimum value. This gain multiplies the theoretically calculated acceleration precontrol values.
- 9841.1 / 9841.2 /
9841.3 *Speed setpoint filter*
- Unit: μs
Value range: 0 – 10000000, step 1
FCB 05 Speed control (page 122) Speed setpoint filter P1/P2/P3.
Is only active in all speed controlled operating modes. It filters the received speed setpoint.
It is important that the "cycle time of the external controller" is set to "0 ms" at startup when the internal speed profile generator is used.
- 9842.1 / 9842.2 /
9842.3 *Actual speed value filter*
- Unit: μs
Value range: 0 – 1000 – 10000000, step 1
Actual speed value filter P1/P2/P3.
This filter is active in the actual speed branch and also in the speed precontrol branch to smoothen the noise of the actual speed value information.
- 9838.1 / 9838.2 /
9838.3 *Acceleration precontrol filter*
- Unit: μs
Value range: 0 – 5000 – 10000000, step 1
Acceleration precontrol filter P1/P2/P3.
Acceleration precontrol filter P1/P2/P3 is only active in all speed controlled FCBs.
It is important that the "cycle time of the external controller" is set to "0 ms" at startup when the internal speed profile generator is used.
- 10058.1 / 10058.2 /
10058.3 *Switched integrator*
- Value range:
- 0 = Switched
The integrator is stopped when the control limit is reached to achieve a low overshoot of the actual speed value when reentering the control range.
 - 1 = Not switched
Is required for the "dual drive" special control function.
- Closed-loop speed controller switched integrator P1/P2/P3
The control limit can be reached with very large setpoint changes at the speed control input. The control limit is characterized by various specified limits that are calculated online (current limit, acceleration limits, motor limits, inverter limits, voltage limit, etc.).

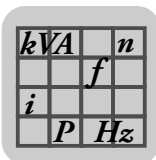

MX Parameter Description

Parameter description of drive data

9994.1 / 9994.2 /
9994.3 Integrator
mode

Value range:

- 0 = Hold
- 1 = Delete
- 2 = "Initialize" using the source of parameter 9995. *Integrator initialization* (page 35).

Speed control integrator mode P1/P2/P3.

The start value of the integrator behavior can be influenced by this parameter.

The changes are naturally very much dependent on the "Integrator integrative time; P9799.1".

The higher the integrative time, the longer lasts the adjustment of the start value to the actual disturbance.

The integrator behavior depends on the selected parameter set.

Hold: The content of the integrator is maintained when the speed control loop opens. When the speed control loop closes again, the torque previously contained in the integrator is directly adjusted at the motor shaft again. This operating mode is particularly useful in hoists to prevent the load from sagging when the brake is released.

The speed control loop can be closed by selecting *FCB 05 speed control* (page 122) or any other FCB (e.g. *FCB 09 Positioning* (page 134)) that activates the speed controller.

At a software reset, the content of the integrator is stored in non-volatile memory from where it is loaded again. With a software cold start (after power off/on), the integrator will always be cleared because the values are not saved when switching the power supply off.

Delete: The content of the integrator is set to zero when the speed control loop opens. When the speed control loop closes once again, the integral component is set to zero and adjusted to a torque of "zero".

Initialize: This setting lets you set the I component of the speed controller (torque) to a predefined value. The source of this value is defined in parameter 9995.1 *Integrator -initialization* (page 35). This value takes effect when the speed control loop closes.

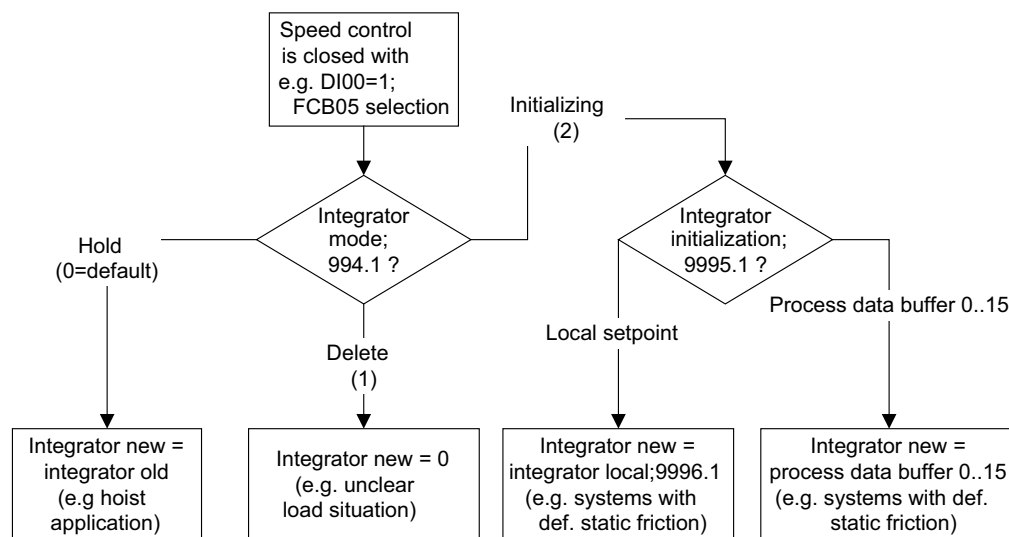

1239639307

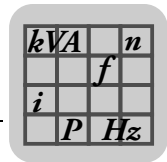

9995.1 / 9995.2 /
9995.3 *Integrator
initialization*

Value range:

- 0 = Local setpoint
from parameter 9996.1 *Local integrator*.
- 1 – 16 = Process data buffer, channel 0 – 15

Speed control integrator initialization source P1/P2/P3.

Takes effect when parameter 9994.1 *Integrator mode* (page 34) is set to "Initialize".

9996.1 / 9996.2 /
9996.3 *Local
integrator*

Unit: %

Resolution: 10^{-3}

Value range: -1000000 – 0 – 1000000, step 1

Speed control integrator initialization local P1/P2/P3.

When the speed control loop closes, the torque of parameter 9996.1 "Local integrator" is directly adjusted at the motor shaft.

It only takes effect if parameter 9994.1 *Integrator mode* (page 34) is set to "Initialize" and -parameter 9995.1 *Integrator initialization* (page 35) is set to "local".

This parameter must also be specified in the user-defined unit.

For default setting of the user-defined unit torque

- Parameter 9555.1 *Torque resolution* (page 57) = $10E-3$.
- Parameter 9556.1 *Torque numerator* (page 57) = 1.

The unit is [$10E-03 \times \% \times$ nominal torque; parameter 9610.1 (page 37)].

This setting can also be made using the bus, see the description on setting the torque, parameter 9555.1 (page 57); parameter 9556.1 (page 57); parameter 9557.1 (page 58).

9817.1 / 9817.2 /
9817.3 *Total mass
moment of inertia*

Unit: kgm^2

Resolution: 10^{-7}

Value range: 0 – 2147483647, step 1

Total mass moment of inertia P1.

Position controller

9843.1 / 9843.2 /
9843.3 *P-gain*

Unit: $10^{-3}/\text{s}$

Value range: 0 – 50000 – 10000000, step 1

Gain X controller P1/P2/P3.

10201.1 / 10201.2
/ 10201.3 *Setpoint
limit position
controller*

Value range:

- 0 = Off
- 1 = On

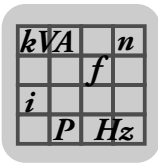

MX Parameter Description

Parameter description of drive data

Equalizing controller

(10060.1) / 10060.2 / 10060.3
NMin source

Value range: See parameter 9995.1 *Integrator initialization* (page 35).
Equalizing controller NMin source P1.
For details, see *FCB 22 Dual drive* (page 159).

(10062.1) / 10062.2 / 10062.3
NMin local

Unit: 10⁻³/min
Value range: -2147483648 – 2147483647, step 1
Equalizing controller NMin local P1.
For details, see *FCB 22 Dual drive* (page 159).

(10059.1) / 10059.2 / 10059.3
NMax source

Value range: See parameter 9995.1 *Integrator initialization* (page 35).
Equalizing controller NMax source P1.
For details, see *FCB 22 Dual drive* (page 159).

(10061.1) / 10061.2 / 10061.3
NMax local

Unit: 10⁻³/min
Value range: -2147483648 – 2147483647, step 1
Equalizing controller NMax local P1.
For details, see *FCB 22 Dual drive* (page 159).

1.2.2 Motor parameter P1/P2/P3

9820.1 / 9820.2 / 9820.3
Motor type

Value range:

- 0 = Asynchronous motor
- 1 = Synchronous motor

Motor type P1/P2/P3.

9732.1 / 9732.2 / 9732.3
Number of pole pairs

Value range: 1 – 3 – 64, step 1
Number of pole pairs P1/P2/P3.
The number of motor pole pairs is set here.

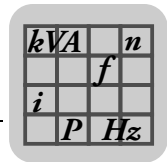

9610.1 / 9610.2 / 9610.3 <i>Nominal torque</i>	Unit: Nm Resolution: 10 ⁻⁵ Value range: 0 – 100000 – 2147483647, step 1 Nominal motor torque P1/P2/P3. The values specified in "torque" in MOVIAXIS® refer to this nominal torque value. All values specified in "current" in MOVIAXIS® refer to the nominal current of the unit.
9861.1 / 9861.2 / 9861.3 <i>Maximum torque</i>	Unit: Nm Resolution: 10 ⁻⁵ Value range: 0 – 2147483647, step 1 Maximum motor torque P1/P2/P3.
9605.1 / 9605.2 / 9605.3 <i>Maximum speed</i>	Unit: 10 ⁻³ /min Value range: 0 – 3000000 – 10000000, step 1 Maximum permitted motor speed P1/P2/P3.
9987.1 / 9987.2 / 9987.3 <i>Maximum current</i>	Unit: mA Value range: 0 – 2000000, step 1 Maximum motor current P1/P2/P3.
9609.1 / 9609.2 / 9609.3 <i>Nominal current I_q</i>	Unit: mA Value range: 0 – 2000000, step 1 I _q nominal current P1/P2/P3.
9819.1 / 9819.2 / 9819.3 <i>Nominal current I_d</i>	Unit: mA Value range: 0 – 2000000, step 1 I _d nominal current P1/P2/P3.
9606.1 / 9606.2 / 9606.3 <i>Nominal flow</i>	Unit: μVs Value range: 0 – 2147483647, step 1 Nominal flow P1/P2/P3.
9736.1 / 9736.2 / 9736.3 <i>Leakage inductance</i>	Unit: H Value range: 0 – 2147483647, step 1 CFC LSigma P1/P2/P3.
9738.1 / 9738.2 / 9738.3 <i>Rotor resistance</i>	Unit: μΩ Value range: 0 – 2147483647, step 1 Rotor resistance P1/P2/P3.

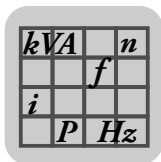

MX Parameter Description

Parameter description of drive data

<p>9737.1 / 9737.2 / 9737.3 <i>Flow time constant</i></p>	<p>Unit: μs</p> <p>Value range: 0 – 10000000, step 1</p> <p>Flow time constant P1/P2/P3.</p>
<p>9816.1 / 9816.2 / 9816.3 <i>Rotor time constant</i></p>	<p>Unit: μs</p> <p>Value range: 0 – 4294967295, step 1</p> <p>Time constant rotor P1/P2/P3.</p>
<p>9834.1 / 9834.2 / 9834.3 <i>Encoder offset</i></p>	<p>Unit: U</p> <p>Resolution: $1/2^{32}$</p> <p>Value range: 0 – 2147483647, step 1</p> <p>Encoder offset P1/P2/P3 is indicated in angular degrees in MotionStudio ($2^{32} = 360\,000$ degrees).</p> <p>The encoder offset refers to the mechanical revolution of the motor. A mechanical revolution is the electrical revolution multiplied by the number of poles specified in -parameter 9732.1 (page 36).</p>
<p><i>Encoder</i></p> <p>9597.1 / 9597.2 / 9597.3 <i>Actual speed source</i></p>	<p>Value range:</p> <ul style="list-style-type: none"> • 0 = No encoder • <u>1 = Encoder 1</u> • 2 = Encoder 2 • 3 = Encoder 3 <p>Source actual speed P1/P2/P3</p> <p>The parameter is set in the parameter tree folder "Motor data".</p> <p>This parameter is used to select the encoder that provides the information for the speed controller, current controller and commutation of the motor control.</p> <p>The source of the actual speed may not be switched to another source during controller enable.</p> <p>Only the encoder assigned to the parameter set number can be chosen as source. This is verified when activating controller enable.</p> <p>See also parameter 9595.2 <i>Connected to drive no.</i> in the "Encoder" chapter (page 116).</p>
<p>9744.1 / 9744.2 / 9744.3 <i>Actual position source</i></p>	<p>Value range:</p> <ul style="list-style-type: none"> • 0 = No encoder • <u>1 = Encoder 1</u> • 2 = Encoder 2 • 3 = Encoder 3 <p>Actual position source P1/P2/P3.</p> <p>The parameter is set in the parameter tree folder "Motor data".</p> <p>This parameter is used to select the encoder that provides the actual position information for the position controller of the motor control.</p>

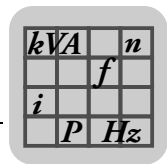

The source of the actual position may be switched to another source during controller enable.

Only the encoder assigned to the parameter set number can be chosen as source. This is verified as long as the controller is enabled.

See also parameter 9595.2 *Connected to drive no.* in the "Encoder" chapter (page 116).

Brake

Brake control

The parameters for the brake function are usually set by the startup process when the connected motor is entered or the data is read from the electronic nameplate.

The brake control is an independent function that is called up directly after the FCBs. It processes the requests of the FCB currently used and controls the control terminal for the brake accordingly.

The brake terminal is monitored for supply voltage and control signal level during the same time interval and depends on the relevant requirements of the FCBs on brake control.

	⚠ CAUTION
	<p>When output stage enable is revoked or output stage inhibit is set, the brake signal is immediately set to "close" and the output stage is disabled => A moving motor makes an emergency stop using the installed brake, or coasts to a halt.</p>

CMP, CMD, DS motors can be equipped with a servo holding brake. In this case, only a very limited number of emergency stops is possible.

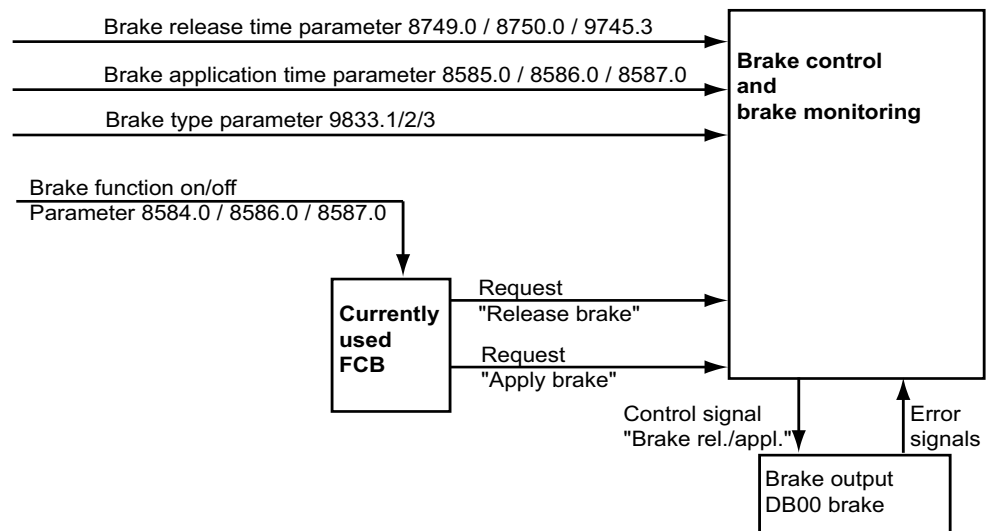

1239643275

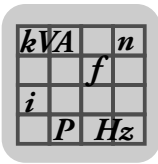

MX Parameter Description

Parameter description of drive data

10230.1 / 10230.2
/ 10230.3 Brake
name

Unit:
Value range:

9833.1 / 9833.2 /
9833.3 Brakes

Value range:

- 0 = None
- 1 = Brake connected to brake rectifier
- 2 = Brake directly connected

Brake type P1.

The control terminal and supply voltage for the brake are monitored:

1. Supply voltage within the specified tolerances or not => Error message "E13 Brake supply". Monitoring is only active when the brake is released or while the brake is being released.
2. No brake connected or brake control output overloaded => Error message "E12 Brake output". The brake message signal is monitored with a delay of $t = 150$ ms after the signal to release the brake has been issued. The current rise time is bridged until the required brake current is reached. Monitoring is active as long as the brake is released.

	⚠ CAUTION
	<p>Monitoring is only active when the brake type parameter is set to "Brake directly connected".</p> <p>The three- or two-wire brake from SEW-EURODRIVE is not monitored (setting: "Brake connected to brake rectifier" or "None").</p>

	INFORMATION
	<p>If parameter 9833.1 / 2 / 3 Brake type is set to "No brake", the brake output is set to "Brake applied".</p> <p>This means that the setting of parameter 8584.0/8586.0/8587.0 Brake function (page 43) has no effect on the brake output.</p>

8749.0 / 8750.0 /
9745.3 Brake
release time

Unit: ms
Value range: 0 – 2000, step 1
Brake release time P1/P2/P3.

During the brake release time, the drive is moved with speed control at the setpoint speed "zero", for example to prevent the load from sagging.

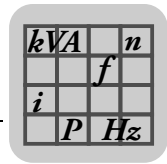

8585.0 / 8587.0 /
9726.3 Brake
application time

Unit: ms
Value range: 0 – 200 – 2000, step 1
Brake application time P1/P2/P3

During the brake application time, the output stage is enabled and speed control with the set value "zero" is active, for example to prevent the load from sagging.

Temperature
sensor

10046.11 /
10046.12 /
10046.13 Temper-
ature sensor type

Value range:
• 0 = No sensor
• 1 = TF / TH
• 2 = KTY(84 – 130)

Temperature sensor type P1/P2/P3.

This parameter is used to set the temperature sensor to ensure it is evaluated properly.

1.2.3 Control functions P1 / P2 / P3

Speed monitoring

8557.0 / 8559.0 /
9721.3 Speed
monitoring

Value range:
• 0 = Off
• 1 = Motor mode
• 2 = Regenerative mode
• 3 = Motor / regenerative mode

Speed monitoring P1/P2/P3.

Is set by the motor startup procedure.

If speed monitoring is not set to "off", the control variable limit of the speed controller are monitored. If a certain adjustable delay time is set for parameter 8558.0 Delay time (page 42), an error response will be triggered. Events in which the control limit is reached for a short time period while the drive is accelerating or decelerating can be blocked using the appropriate setting in parameter 8558.0 Delay time (page 42).

The control variable limit is based on all acceleration limit values. This includes data such as system limits, application limits, FCB limits, maximum motor torque limits as well as maximum axis current and thermally limited axis current.

Also see figure "Torque/current controller" (page 30).

Motor / regenerative modes are distinguished as follows:

- Sign of (speed × torque) = positive → motor speed limit → results in E08: Suberror code 1.
- Sign of (speed × torque) = negative → regenerative speed limit → results in E08: Suberror code 2.

Monitoring is always activated at speeds lower than 10 rpm (if parameter 88557 ≠ 0). This is independent of whether the cause is regenerative or associated with the motor. This is because the actual speed value information is distorted by noise during resolver evaluations and at small actual speeds. In this way, it cannot be clearly defined whether a motor or regenerative load is present.

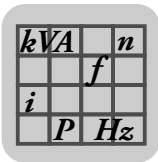

MX Parameter Description

Parameter description of drive data



INFORMATION

If the actual speed exceeds the maximum permitted system limits of parameter 9579.1 (page 51) "positive" and parameter 9579.10 (page 51) "negative", a unit error will be triggered. Unlike monitoring of the control limit, this type of monitoring cannot be deactivated or limited by setting speed monitoring to "off".

8558.0 / 8560.0 /
9722.3 Speed
monitoring delay
time

Unit: ms

Value range: 0 – 50 – 1000, step 1

N monitoring delay time P1/P2/P3.

Is set by the motor startup procedure.

When the control limit of the speed controller is reached, a timer responsible for the delay time is started. Once the delay time is exceeded, a unit error is triggered. If the speed controller leaves its control limit before the delay time expires, the timer will be decremented until "zero" is reached.

Also see the following figure.

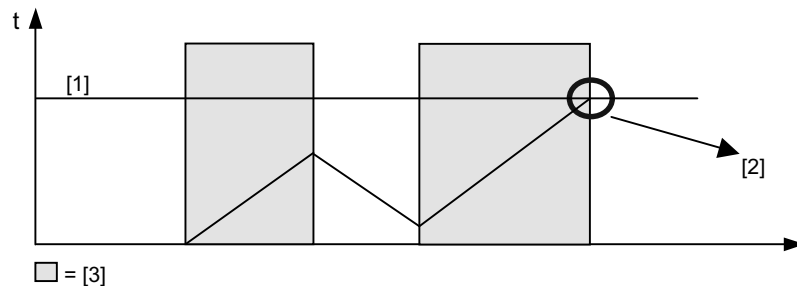

1240197003

[1] Parameter "8558.0 Delay time"

[2] Trigger error E08

[3] Control limit

9718.1 / 9718.2 /
9718.3 Speed
monitoring reset
time factor

Unit: ms

Value range: 0 – 1000, step 1

N monitoring reset time factor P1/P2/P3.

Is set by the motor startup procedure.

Use the "Speed monitoring reset time" factor to set how fast the timer decrements when leaving the control limit compared to the delay time. Usually this factor is equal to 1. For example, a factor of 3 means the counter decrements three times faster.

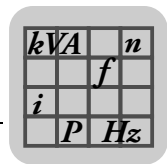

Brake function

8584.0 / 8586.0 /
9725.3 Brake
function

Value range:

- 0 = Off
- 1 = On

Brake function P1.

This parameter has an effect when stopping in STOP FCBs 14, 13 and 12, and when starting in the other FCBs (for example, FCB 05 (page 122), 09 (page 134))

See figure "Brake control" (page 39).

This parameter can be used to activate or deactivate the brake function regardless of whether a brake is connected (parameter 9833.1/2/3 Brake type (page 40)).

- **0 = Off**

When the drive is stopped, the brake is not applied if motor standstill is detected. The output stage remains enabled and the drive adjusts to the speed setpoint "zero", unless hold control is active.

Upon enable, the drive starts running without delay caused by a brake release time.

- **1 = On**

When the drive is stopped, the brake is applied if motor standstill is detected. The brake application time is taken into account. The output stage is blocked and the drive is electrically connected with no torque if this brake application time has expired.

When the motor brake is applied, asynchronous motors are premagnetized upon receiving an enable signal.

If synchronous motors are connected, the output stage and control will be activated.

Then the brake is released taking the brake release time into account with activated control. Once the brake release time has elapsed, the selected FCB is activated with the set setpoint.

	INFORMATION
	<p>The "Brake function" parameter has no effect on the brake output if parameter 9833.1/2/3 Brake type" (page 40) is set to "no brake". This way, the brake output is permanently set to the status "Apply brake".</p>

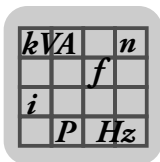

MX Parameter Description

Parameter description of drive data

Standstill current function

9826.11 /
9826.12 / 9826.13
Standstill current function

Value range:

- 0 = Off
- 1 = On

Activates/deactivates the standstill current function. This function is only effective for asynchronous motors. In a synchronous motor, **no** current is impressed even if the standstill current function is activated. A prerequisite for the standstill current function is that the motor has a brake and that the brake function is activated. Another prerequisite for the standstill current function is the activated controller enable (DI00 = "1").

In case of an activated stop (FCB00, FCB13, FCB14, FCB15), the standstill current function automatically impresses a current which is defined in the parameter "standstill current value". In case of a travel command, the activated standstill current function shortens the premagnetization time in the standstill phase until the motor begins to turn. If a standstill current of 100% is set, the premagnetization time is reduced to zero, as in this case the standstill current equals the magnetization current.

9826.21 /
9826.22 / 9826.23
Standstill current value

Unit: %

Value range: 0 – 100 – 200, step 1

Defines the magnitude of the standstill current of the motor in [%], based on the nominal magnetization current "Nominal current Id" of the motor, also see parameter 9819.1 – 3 (page 37).

Limit switch evaluation

A certain travel range of a drive can be monitored using hardware limit switches. Software limit switch monitoring can be activated if there are no hardware limit switches or for early detection purposes. Each limit switch (positive or negative software limit switch) can be activated/deactivated independently of one another.

Furthermore, the source of the software limit switches (encoder1 – encoder3) can also be set. A prerequisite for software limit switch monitoring is that the selected encoder is referenced.

The acknowledgement behavior applies both to software and hardware limit switches. You can set whether acknowledgement is required in the error response. You can choose between "Auto-reset" or "Waiting".

When a limit switch was hit, the error must be acknowledged depending on the programmed limit switch response before the drive moves clear of the limit switch. The acknowledgement is accepted even if the drive has not yet reached standstill. In this case, movement clear of the limit switch will be triggered immediately once the axis stop was detected.

Limit switch processing checks the sign of the currently present setpoint (e.g. target position of positioning). The drive moves along with the currently set ramp of the currently set FCB if this setpoint results in leaving the limit switch.

If the setpoint makes the drive move further into the limit switch, the drive will remain stopped. This "moving clear" is caused by *FCB 11 Limit switch*.

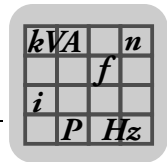

Once the drive has moved clear of the limit switch, the currently selected FCB is chosen and the drive continues to move using the setpoints and limits of this FCB.

	INFORMATION
	For influencing limit switches by reversing the direction of rotation, see parameter 8537.0 <i>Direction of rotation reversal</i> (page 23).

The limit switch signals are debounced by the software (debouncing time 200 ms).

Moving clear of hardware limit switches

A certain travel range of a drive can be monitored using hardware limit switches. If hardware limit switches are not used or, for example, an early warning alarm should be activated when a specific position is exceeded, the software limit switches integrated in MOVIAXIS® can be activated.

Each limit switch (positive or negative software limit switch) can be activated/deactivated independently of one another. Furthermore, the source of the software limit switches (encoder1 – encoder3) can also be set. If the drive hits one of the two software or hardware limit switches, it reacts using one of the responses set by the user.

Software and hardware limit switches basically react in the same way. In order to enable the monitoring function, the appropriate encoder must be referenced.

9729.6 / 9729.7 / 9729.8 Hardware limit switch response

- Value range:
- 0 = No response
 - 6 = Emergency stop / waiting
 - 10 = Stop at system limit / waiting
 - 18 = Emergency stop / autoreset
 - 19 = Stop at system limit / autoreset

Hardware limit switch response P1/P2/P3.

The hardware limit switch response sets the error response when a hardware limit switch is hit.

- **No response**

Error is ignored

- **Emergency stop / waiting**

The motor is stopped along the emergency stop ramp. After a restart, the axis performs a warm start. This means that the axis is immediately ready to operate again (without delay).

- **Stop at system limit/waiting**

The motor is stopped at the system limit. After a restart, the axis performs a warm start. This means that the axis is immediately ready to operate again (without delay).

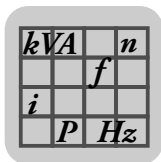

MX Parameter Description

Parameter description of drive data

- **Emergency stop / autoreset**

The motor is stopped along the emergency stop ramp. No reset is expected.

- **Stop at system limit / autoreset**

The motor is stopped at the system limit. No reset is expected.

For detailed information about this topic, refer to the operating instructions in the "Operation" chapter.

9824.1 / 9824.2 /
9824.3 *Software
limit switch
monitoring source*

Value range: See parameter 9744.1 *Actual speed source* (page 117).

Software limit switch monitoring source P1/P2/P3.

9729.13 / 9729.14
/ 9729.15 *Soft-
ware limit switch
response*

Value range: see parameter 9729.6 *Hardware limit switch response* (page 45).

Software limit switch response P1/P2/P3.

9798.1 / 9798.2 /
9798.3 *Monitor
software limit
switch negative*

Value range:

- 0 = Off
- 1 = On

Monitor software limit switch negative P1/P2/P3.

- Off

Software limit switch is not monitored.

- On

Software limit switch is monitored.

9961.1 / 9961.2 /
9961.3 *Software
limit switch
negative*

Unit: U

Resolution: 1/65536

Value range: -2147483648 – 2147483647, step 1

Negative software limit switch P1/P2/P3.

9801.1 / 9801.2 /
9801.3 *Monitor
software limit
switch positive*

Value range:

- 0 = Off
- 1 = On

Monitor software limit switch positive P1/P2/P3.

- Off

Software limit switch is not monitored.

- On

Software limit switch is monitored.

10064.1 / 10064.2
/ 10064.3 *Soft-
ware limit switch
positive*

Unit: U

Resolution: 1/65536

Value range: -2147483648 – 2147483647, step 1

Positive software limit switch P1/P2/P3.

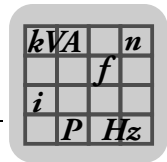

"Motor at standstill" signal

10056.1 / 10056.2 / 10056.3 Velocity threshold "Motor at standstill" – status bit

Unit: 10⁻³/min
Value range: 10000 – 50000, step 1
Velocity threshold motor at standstill P1/P2/P3
If the actual velocity is lower than this value, the "Motor at standstill" bit is set once the filter time of parameter "100057.1" has expired. If the velocity threshold is exceeded during the filter time, the filter will be reset to "zero" and starts again when the actual velocity drops below the velocity threshold again.

10057.1 / 10057.2 / 10057.3 Filter time "Motor at standstill" – status bit

Unit: ms
Value range: 0 – 25, step 1
Filter time motor at standstill P1/P2/P3
See parameter 10056.1 Velocity threshold motor at standstill (page 47).

Motor protection

When MOVIAXIS® detects that the maximum temperature of the motor is exceeded, it can respond in five different ways. These responses can be configured at startup. The responses range from "No response", through "Display", to different stop types.

MOVIAXIS® has a total of four different types / options to monitor the thermal properties of a motor and protect it from overload / irreparable damage. The types differ in quality and response capability.

1. Motor monitoring with TF / TH sensor

With this method, the configured action is executed when the limit temperature is exceeded.

2. Motor monitoring for types CMP, CM, CMD with KTY sensor

With this method, the configured action is triggered using temperature recording (in °C) and evaluation of the warning threshold of the motor when a limit temperature is exceeded. For all specified SEW-EURODRIVE motors, a KTY is used as a temperature sensor (initial values) to calculate the amount and time of the motor currents (history and course) in a motor-specific, thermal motor model in MOVIAXIS®.

The KTY also protects motors, e.g. CMP40, for which a purely mechanical temperature detection function would be too slow so that the motor might be damaged as a result. This functionality is only available for the specified SEW-EURODRIVE motors. It is the best way to ensure thermal protection for SEW-EURODRIVE servomotors.

3. Motor monitoring with KTY sensor

With this method, the configured action is executed when the limit temperature is exceeded.

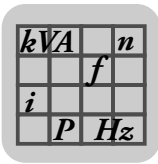

MX Parameter Description

Parameter description of drive data

4. Motor monitoring with KTY sensor and I^2t table

With this method, the KTY sensor is used to read in initial temperature values. A torque/speed curve point table (max. 8 curve points) supplied by the motor manufacturer can be used to adjust the dynamic behavior, or the values can be calculated in the inverter.

The combination of the two values can be used to offer better protection for the motor than is available with a KTY alone.

This is the best way to protect a non-SEW motor connected to MOVIAXIS®.

The motor protection / connected motor temperature sensor is set at startup.

KTY is set: The implementation monitors wire breakage ($> 1767 \Omega$; approx. $196 \text{ }^\circ\text{C}$ with KTY84 – 130) and short circuit ($< 305 \Omega$; approx. $-52 \text{ }^\circ\text{C}$ with KTY).

TF/TH is set: Implementation switches at 1725Ω (approx. 117 mV).

8904.0 / 8905.0 /
10046.1 (not in
parameter tree)

Value range:

- 0 = No sensor
- 1 = TF / TH
- 2 = KTY84 – 130

Temperature sensor type TMU1/TMU2/TMU3.

10063.1 /
10063.2 / 10063.3
(not in parameter
tree)

Value range:

- 0 = TMU1
- 1 = TMU2
- 2 = TMU3

Thermal motor monitoring used in parameter set P1/P2/P3.

Three thermal monitoring functions are available to being able to operate three motors alternately on one inverter. As default, parameter set 1 is assigned monitoring 1, parameter set 2 is assigned monitoring 2, etc.

For example, the thermal monitoring used in parameter set 2 should be set to "1" if the same motor as in parameter set 1 is used in parameter set 2. When using a model, doing so will prevent that heat drawn into the motor is distributed to several models and distorts the model values.

9872.1 / 9872.2 /
9872.3 Temperature
KTY sensor

Unit: $^\circ\text{C}$

Resolution: 10^{-6}

KTY temperature sensor TMU1/TMU2/TMU3.

Temperature of the sensor TMUx accurate within $\pm 5.7 \text{ }^\circ\text{C}$.

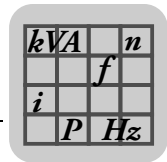

9800.1 / 9800.2 /
9800.3 *Thermal
motor model
temperature* Unit: °C
Resolution: 10⁻⁶
Winding temperature model P1/P2/P3
Temperature of the thermal motor model P1/P2/P3

9705.1 / 9705.2 /
9705.3 *KTY sensor
motor utilization* Unit: %
Resolution: 10⁻³
KTY TMU1/TMU2/TMU3 motor utilization
The following applies to the relative utilization values:

$$\text{Motor utilization KTY sensor} = \frac{\text{Temperature KTY sensor} - 40 \text{ °C}}{T_{\text{Motor_max}} - 40 \text{ °C}}$$

A temperature of 40 °C corresponds to a utilization of 0%.

9874.1 / 9874.2 /
9874.3 *Thermal
motor model motor
utilization* Unit: %
Resolution: 10⁻³
Motor utilization model P1/P2/P3.

The motor utilization uses a motor model to calculate the temperature transition of the motor to the KTY sensor. The injected current is also taken into account. The display is output in % and starts at a motor model temperature of 40 °C = 0% and a shutdown temperature = 100%.

$$\text{Motor utilization thermal model} = \frac{\text{Thermal motor model} - 40 \text{ °C}}{T_{\text{Motor_max}} - 40 \text{ °C}}$$

9962.1 / 9962.2 /
9962.3 *Motor
utilization pre-
warning threshold* Unit: %
Resolution: 10⁻³
Value range: 0 – 80000 – 100000, step 1
Motor utilization prewarning threshold TMU1/TMU2/TMU3

The prewarning threshold refers to parameter 9705.1 *KTY sensor motor utilization* (page 49) and parameter 9874.1 *Thermal motor model motor utilization* (page 49) (if calculated). If one of the parameters exceeds this threshold, an error is triggered with the error response "Display only".

The 7-segment display shows the "E69" status but the axis does not respond (continues to operate).

- E69.1 KTY: Warning threshold exceeded,
- E69.2 Synchronous model: Warning threshold exceeded,
- E69.3 I²t-model: Warning threshold exceeded.

The function "Prewarning motor temperature (KTY)" can be applied to a status word and consequently also to an output to allow a timely response in the machine controller.

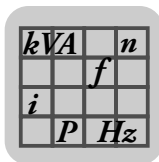

MX Parameter Description

Parameter description of drive data

9729.9 / 9729.10 /
9729.11 TF / TH /
KTY signal
response

Value range:

- 0 = No response
- 1 = Display only
- 2 = Output stage inhibit / locked
- 3 = Stop at emergency stop limit / locked
- 5 = Output stage inhibit / waiting
- 6 = Stop at emergency stop limit / waiting
- 8 = Stop at application limit / waiting
- 9 = Stop at application limit / locked
- 10 = Stop at system limit / waiting
- 11 = Stop at system limit / locked

If the parameter *9705.1 KTY sensor motor utilization* (page 49) and parameter *9874.1 Thermal motor model motor utilization* (page 49) (if calculated) exceed 100 %, error message E31.x will be issued. The error response to this message is set in response TF/TH/KTY message.

- **No response**

Error is ignored

- **Display only**

The 7-segment display shows the "E031" status but the axis does not respond (continues to operate).

- **Output stage inhibit / locked**

The axis changes to the controller inhibit state and applies the mechanical brake, if installed. If no brake is installed, the motor will coast to a halt. After a reset, the axis performs a system restart.

- **Stop at emergency stop limit / locked**

The motor is stopped along the emergency stop ramp. After a reset, the axis performs a system restart.

- **Output stage inhibit/waiting**

The axis changes to the controller inhibit state and applies the mechanical brake, if installed. If no brake is installed, the motor will coast to a halt. After a reset, the axis performs a warm start. This means that the axis is immediately ready to operate again (without delay).

- **Stop at emergency stop limit / waiting**

The motor is stopped along the emergency stop ramp. After a reset, the axis performs a warm start. This means that the axis is immediately ready to operate again (without delay).

- **Stop at application limit/waiting**

The motor is stopped at the application limit. After a reset, the axis performs a warm start. This means that the axis is immediately ready to operate again (without delay).

- **Stop at application limit / locked**

The motor is stopped at the application limit. After a reset, the axis performs a system restart.

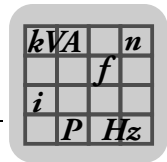

- **Stop at system limit/waiting**

The motor is stopped at the system limit. After a reset, the axis performs a warm start. This means that the axis is immediately ready to operate again (without delay).

- **Stop at system limit / locked**

The motor is stopped at the system limit. After a reset, the axis performs a system restart.

For detailed information about this topic, refer to the operating instructions in the "Operation" chapter.

1.2.4 Limit values P1/P2/P3

System values can only be changed when the controller is disabled.

Application limits can be changed when the controller is enabled.

System limits

9573.1 / 9573.2 /
9573.3 Maximum
acceleration

Unit: 10⁻²/(min×s)

Value range: 0 – 300000 – 2147483647, step 1

Maximum velocity within the system limits in user-defined units.

Special handling with FCB 00, 05 (page 122), 11, 12 (page 144), 13, 14, 15, 20 (page 153) for system limit acceleration = 0: The value 0 completely deactivates the acceleration limit. The application or emergency stop limits as well as local values are **not effective**.

9574.1 / 9574.2 /
9574.3 Maximum
deceleration

Unit: 10⁻²/(min×s)

Value range: 0 – 300000 – 2147483647, step 1

Maximum deceleration within the system limits in user-defined units.

Special handling with FCB 00, 05 (page 122), 11, 12 (page 144), 13, 14, 15, 20 (page 153) for system limit acceleration = 0: The value 0 completely deactivates the acceleration limit. The application or emergency stop limits as well as local values are **not effective**.

9579.1 / 9579.2 /
9579.3 Maximum
positive velocity

Unit: 10⁻³/min

Value range: 0 – 10000000, step 10

Maximum positive speed within the system limits in user-defined units.

9579.10/9579.11 /
9579.12 Maxi-
mum negative
velocity

Unit: 10⁻³/min

Value range: 0 – 10000000, step 10

Maximum negative speed within the system limits in user-defined units.

9580.1 / 9580.2 /
9580.3 Maximum
torque

Unit: %

Resolution: 10⁻³

Value range: 0 – 100000 – 100000, step 1

Torque limit within the system limits in user-defined units.

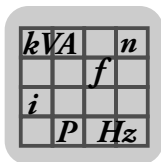

MX Parameter Description

Parameter description of drive data

<p>9583.1 / 9583.2 / 9583.3 <i>Maximum jerk</i></p>	<p>Unit: 1/(min×s²) Value range: 1 – <u>2147483647</u>, Step 1 Maximum jerk limit within the system limits. Special handling with FCB 00, 07 (page 131), 13, 14, 15 for jerk = 0: The value 0 completely deactivates the acceleration limit. Application or emergency stop limits as well as local values are not effective.</p>
<p><i>Emergency stop</i> 9576.1 / 9576.2 / 9576.3 <i>Emer- gency stop deceleration</i></p>	<p>Unit: 10⁻²/(min×s) Value range: 0 – 300000 – 2147483647, step 1 Emergency stop deceleration in user-defined units.</p>
<p><i>Application limits</i> 9571.11 / 9571.12 / 9571.13 <i>Maximum acceleration source</i></p>	<p>Unit: Value range: See parameter 9598.1 / 10440.1 <i>Velocity setpoint source</i> (page 123). Description: See parameter 9598.1 / 10440.1 <i>Velocity setpoint source</i> (page 123).</p>
<p>9571.1 / 9571.2 / 9571.3 <i>Maximum acceleration</i></p>	<p>Unit: 10⁻²/(min×s) Value range: 0 – 300000 – 2147483647, step 1 Maximum acceleration within the application limits in user-defined units.</p>
<p>9572.11 / 9572.12 / 9572.13 <i>Maximum deceleration source</i></p>	<p>Unit: Value range: See parameter 9598.1 / 10440.1 <i>Velocity setpoint source</i> (page 123). Description: See parameter 9598.1 / 10440.1 <i>Velocity setpoint source</i> (page 123).</p>
<p>9572.1 / 9572.2 / 9572.3 <i>Maximum deceleration</i></p>	<p>Unit: 10⁻²/(min×s) Value range: 0 – 300000 – 2147483647, step 1 Maximum deceleration within the application limits in user-defined units.</p>
<p>9716.21 / 9716.22 / 9716.23 <i>Maxi- mum positive velocity source</i></p>	<p>Unit: Value range: See parameter 9598.1 / 10440.1 <i>Velocity setpoint source</i> (page 123). Description: See parameter 9598.1 / 10440.1 <i>Velocity setpoint source</i> (page 123).</p>
<p>9716.1 / 9716.2 / 9716.3 <i>Maximum positive velocity</i></p>	<p>Unit: 10⁻³/min Value range: 0 – 10000000, step 10 Maximum positive speed within the application limits in user-defined units.</p>

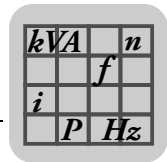

- 9716.31 / 9716.32 / 9716.33 *Maximum negative velocity source* Unit: Value range: See parameter 9598.1 / 10440.1 *Velocity setpoint source* (page 123). Description: See parameter 9598.1 / 10440.1 *Velocity setpoint source* (page 123).
- 9716.10 / 9716.11 / 9716.12 *Maximum negative velocity* Unit: 10⁻³/min Value range: 0 – 10000000, step 10 Maximum negative speed within the application limits in user-defined units.
- 9740.11 / 9740.12 / 9740.13 *Maximum torque source* Unit: Resolution: Value range: See parameter 9598.1 / 10440.1 *Velocity setpoint source* (page 123). Description: See parameter 9598.1 / 10440.1 *Velocity setpoint source* (page 123).
- 9740.1 / 9740.2 / 9740.3 *Maximum torque* Unit: % Resolution: 10⁻³ Value range: 0 – 100000 – 100000, step 1 Torque limit within the application limits in user-defined units.
- 9582.11 / 9582.12 / 9582.13 *Maximum jerk source* Unit: Value range: See parameter 9598.1 / 10440.1 *Velocity setpoint source* (page 123). Description: See parameter 9598.1 / 10440.1 *Velocity setpoint source* (page 123).
- 9582.1 / 9582.2 / 9582.3 *Maximum jerk* Unit: 1/(min×s²) Value range: 1 – 2147483647, Step 1 Maximum jerk limit within the application limits.
- Modulo limits*
- 9594.10 / 9594.11 / 9594.12 *Modulo overflow* Unit: U Resolution: 1/65536 Value range: -2147483648 – 2147483647, step 1 Modulo overflow is needed in all modulo operating modes, e.g. in *FCB 09 Positioning* (page 134). Modulo overflow specifies the position from which an overflow takes place. The parameter is set in the user-defined units and has residual management for infinite gear ratios (set using the user-defined unit numerator / denominator factor at motor startup), for example. Parameter 9998.1 *Positioning mode* (page 114) should be set to "ON". This means endless positioning is possible in one direction without losing positions within the modulo travel range.

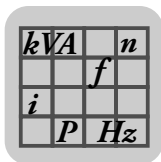

MX Parameter Description

Parameter description of drive data

9594.1 / 9594.2 /
9594.3 Modulo
underflow

Unit: U

Resolution: 1/65536

Value range: -2147483648 – 2147483647, step 1

Modulo underflow is the opposite of modulo overflow. This means it is the start of the modulo travel range. In many applications it is "0" but can also range between -180° and + 180°.

1.2.5 User-defined units P1/P2/P3

MOVIAXIS® offers customers the option of using the controller to send process output data for the position, speed, acceleration and torque to MOVIAXIS® in user-defined units.

In the axis, this process data is converted into internal units (basis: increments) in the setpoint cycle of a minimum of 500 µs.

The same process applies to the process input data returned from MOVIAXIS® to the controller. The data for position, speed, or acceleration are converted into the customer's user units.

The big advantage for customers / PLC programmers is that they do not have to convert the complex physical conditions in the machine into SEW-EURODRIVE-specific units in their programs. Customers can simply select the units most suitable for their applications and send them as specifications to MOVIAXIS®.

For example, customers can specify the following:

- For the position
 - "Compartments", "Packages", "Bottles", etc.
- For the speed
 - "Bottles / minute", "Pouches / second", etc.
- For the acceleration
 - "Pouches / seconds²", "Compartments/ min×s", etc.

Position

9539.1 – 4
9540.1 – 4
9541.1 – 4 *Position*
unit text

Displays the unit text of the position entered by the user. The text consists of a maximum of 16 characters and is set to "Rev." as default, which corresponds to one motor revolution. It is set at motor startup.

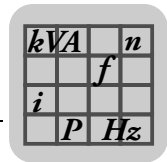

9542.1 / 9542.2 /
9542.3 Position
resolution

Value range:

- 0 = 0
- 1 = 1
- 2 = 2
- 3 = 3
- 4 = 4
- 5 = 5
- 6 = 6

The position resolution interprets the decimal places because communication buses communicate using integers only.

Example: The position resolution is "3", the user-defined unit is millimeters. This means that the number "1000" is interpreted via the bus as "1.000" mm.

The parameter tree in MotionStudio displays all values already with decimal point.

9543.1 / 9543.2 /
9543.3 Position
numerator

Value range: 1 – 65536 – 16777215, step 1

The numerator/denominator factor is used for converting user-defined units into MOVIAXIS® basic units. The basic unit is "revolution" with four decimal places. It is set at motor startup.

9544.1 / 9544.2 /
9544.3 Position
denominator

See parameter 9543.1 Position numerator (page 55). Default value: 1000.

Velocity

9532.1 – 4
9533.1 – 4
9534.1 – 4 Velocity
unit text

Displays the unit text of the velocity entered by the user. The text consists of a maximum of 16 characters and is set to "rpm". It is set at motor startup.

9535.1 / 9535.2 /
9535.3 Velocity
resolution

Value range:

- 0 = 0
- 1 = 1
- 2 = 2
- 3 = 3
- 4 = 4
- 5 = 5
- 6 = 6

The velocity resolution interprets the decimal places because communication buses communicate using integers only.

Example: The velocity resolution is "3" and the user-defined unit is "rpm". This means that the number "1000" is interpreted via the bus as "1.000 rpm".

The parameter tree in MotionStudio displays all values already with decimal point.

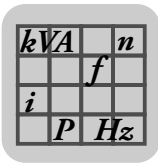

MX Parameter Description

Parameter description of drive data

9536.1 / 9536.2 /
9536.3 *Velocity
numerator*

Value range: 1 – 16777215, step 1

The numerator/denominator factor is used for converting user-defined units into MOVIAXIS® basic units. The basic unit is "rpm" with three decimal places. It is set at motor startup.

9537.1 / 9537.2 /
9537.3 *Velocity
denominator*

See parameter 9536.1 *Velocity numerator* (page 56).

Acceleration

9546.1 – 4
9547.1 – 4
9548.1 – 4 *Accel-
eration unit text*

Displays the unit text for the acceleration entered by the user. The text consists of a maximum of 16 characters and is set to "rpm". It is set at motor startup.

9549.1 / 9549.2 /
9549.3 *Accelera-
tion resolution*

Value range:

- 0 = 0
- 1 = 1
- 2 = 2
- 3 = 3
- 4 = 4
- 5 = 5
- 6 = 6

The acceleration resolution interprets the decimal places because communication buses communicate using integers only.

Example: The acceleration resolution is "3" and the user-defined unit is "rpm×s". This means that the number "1000" is interpreted via the bus as "1.000 rpm×s".

The parameter tree in MotionStudio displays all values already with decimal point.

9550.1 / 9550.2 /
9550.3 *Accelera-
tion numerator*

Value range: 1 – 16777215, step 1

The numerator/denominator factor is used for converting user-defined units into MOVIAXIS® basic units. The basic unit is "rpm×s" with three decimal places. This means one speed change per second. It is set at motor startup.

9551.1 / 9551.2 /
9551.3 *Accelera-
tion denominator*

See parameter 9550.1 *Acceleration numerator* (page 56).

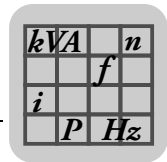

Torque

Torque setting:

The default setting displays the torque in "%" of the rated motor torque selected at startup.

- Torque resolution = 3
- Torque numerator = 1
- Torque denominator = 1
- Torque unit text = "%"

Example:

Set user-defined unit "Newton meter":

- Torque parameter "9552.1 – 4 unit text" = "Nm",
- Torque parameter "9555.1 Resolution" = 3.

$$\frac{\text{Parameter "9556.1 Torque numerator"}}{\text{Parameter "9557.1 Torque denominator"}} = \frac{100}{\text{Parameter "9610.1 Nominal torque"}}$$

→ In the parameter tree, torques are entered in "Nm" with three decimal places.

→ The torque has the unit [10⁻³ Nm] via the bus to the PDOs.

9552.1 – 4
9553.1 – 4
9554.1 – 4 Torque
unit text

Displays the customer's unit text for torque. The text consists of a maximum of 16 characters and is set to "%" as default. It is set at motor startup.

9555.1 / 9555.2 /
9555.3 Torque res-
olution

Value range:

- 0 = 0
- 1 = 1
- 2 = 2
- 3 = 3
- 4 = 4
- 5 = 5
- 6 = 6

The torque resolution interprets the decimal places only for the MotionStudio user interface because communication buses communicate using integers only.

Example: The acceleration resolution is "3" and the user-defined unit is Nm. This means that the number "1000" is interpreted via the bus as "1 Nm".

The parameter tree in MotionStudio displays all values already with decimal point.

9556.1 / 9556.2 /
9556.3 Torque
numerator

Value range: 1 – 16777215, step 1

The numerator/denominator factor is used for converting user-defined units into MOVIAXIS® basic units. The basic unit is "%" of the motor torque with three decimal places. It is set at motor startup.

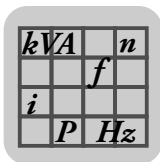

MX Parameter Description

Parameter description of drive data

9557.1 / 9557.2 / 9557.3 Torque denominator See parameter 9550.1 Acceleration numerator (page 56).

1.2.6 Reference travel P1/P2/P3

MOVIAXIS® offers a number of options for reference travel. The reference travel type "Reference to fixed stop" is new.

The aim of reference travel is to reference / match the drive and its position data with the machine design. Referencing is used to identify the real zero point of the drive. This value is then used to define distances necessary for positioning processes.

MOVIAXIS® offers the following reference travel types:

- Deactivated
- Zero pulse negative direction
- Negative end reference cam
- Positive end reference cam
- Positive limit switch
- Negative limit switch
- No reference travel
- Reference cam flush limit switch positive
- Reference cam flush limit switch negative
- Fixed stop positive
- Fixed stop negative

The reference travel types differ according to the first search direction or the switching contact (reference cam, limit switch or fixed stop) used for referencing. Reference travel can apply to all three encoders.

Using the reference point determined by reference travel, the machine zero point can be changed using the reference offset according to the following equation.

Machine zero = reference position - reference offset

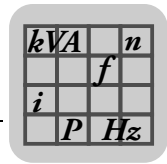

9658.2 / 10442.1 /
10443.1 Reference
travel type

Value range:

- 0 = Deactivated
- 1 = Zero pulse negative direction
- 2 = Negative end reference cam
- 3 = Positive end reference cam
- 4 = Positive limit switch
- 5 = Negative limit switch
- 6 = No reference travel
- 7 = Reference cam flush with positive limit switch
- 8 = Reference cam flush with negative limit switch
- 9 = Fixed stop positive
- 10 = Fixed stop negative

Reference travel types:

- General information about reference travel

For applications using absolute positioning commands, you must define the reference point (machine zero). When using absolute encoders, the reference point must be defined once at initial startup. With all other encoder types, machine zero must be defined each time the machine is switched on.

MOVIAXIS® supports 10 different reference travel types that are set via the parameter 9658.2 Reference travel type.

If referencing is set to the hardware limit switches and / or the reference cam, these must be set as binary inputs in the control word.

If a hardware limit switch is hit during reference travel type 1 or 2 and the reference point has not yet been found, the drive turns and continues reference travel in the other direction.

Machine zero = reference point + reference offset.

The status "Referenced" is reset when the servo inverter is switched off or if error messages relating to the position measuring system are issued.

An exception are absolute encoders, see section below. For Hiperface® and SSI absolute encoders, the status "referenced" is always set and is only reset during reference travel. The status "Not referenced" remains if the reference travel is canceled.

When deciding whether to reference to the reference cam or zero pulse, note the following points:

- The zero pulse shifts when the motor is replaced.
- The reference cam could become inaccurate as a result of age, wear or switching hysteresis.
- If the reference point is determined using the zero pulse and reference cam, and the zero pulse is located exactly at the end of the reference cam, the switching transition of the reference cam may be detected before or after the zero pulse (switching hysteresis). The result may be a reference position which varies by a motor revolution from one time to the next. The situation can be remedied by shifting the reference cam by about half a motor revolution.

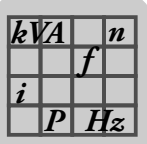

MX Parameter Description

Parameter description of drive data

- Unidirectional drives can only be referenced using a reference cam. Also note that there is no defined distance between the reference cam and zero pulse of the encoder for non-integer ratios. This means that in this case only the end of the reference cam can be selected as the reference point.
- The length of the reference cam and the reference speeds must be selected so the drive can reliably decelerate to the slower reference speed (reference speed 2) on the reference cam. The end of the reference cam or the closest zero pulse of the encoder system can be used as reference point.
- The zero pulse can only be used as a reference point when the encoder has a zero pulse and the zero track is connected to the servo inverter.

As an option, travel to the start position can be selected after the reference procedure for each reference travel type using the parameter *9656.1 Travel to start position* (page 71). This allows you to freely define the drive position regardless of the reference point using *FCB 12 Reference travel* (page 144). This dispenses with the controller performing a positioning travel procedure. The start position is set using parameter *9730.2 Start position* (page 72). The travel speed to the start position is set using parameter *9731.1 Start position velocity* (page 72).

Explanation of symbols for the figures "Reference travel types"

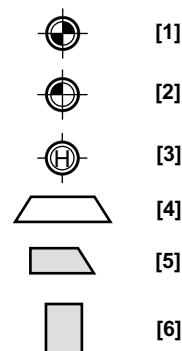

1240575627

- [1] Reference point
- [2] Machine zero
- [3] Stop position after start position travel (optional)
- [4] Reference cam
- [5] Hardware limit switch
- [6] Fixed stop

- Left zero pulse

kVA	n
	f
i	
P	Hz

For this reference travel type, it is mandatory to set parameter "9750.1 Referencing to zero pulse" (page 71) to "YES".

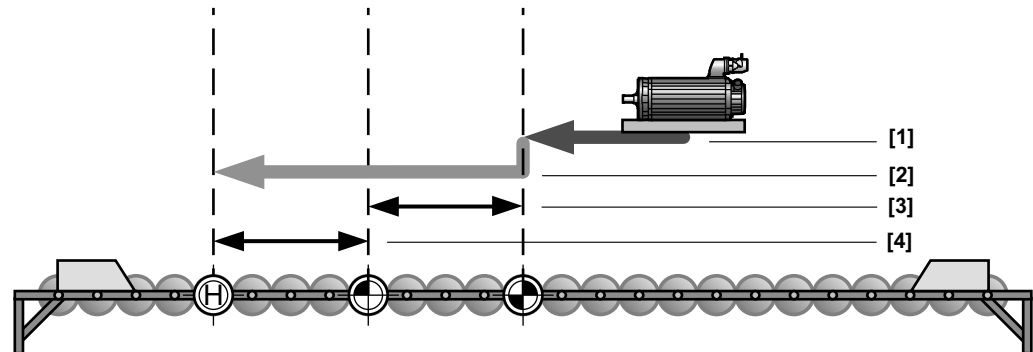

1240733707

- [1] 9731.2 Clear velocity (page 72)
- [2] 9731.1 Start position velocity (page 72)
- [3] 9730.1 Reference offset (page 72)
- [4] 9730.2 Start position (page 72)

MX Parameter Description

Parameter description of drive data

The reference position is the first zero pulse CCW of the starting position of reference travel. A reference cam is not required. Only parameter 9731.2 *Clear velocity* (page 72) (reference speed 2) is used for reference travel.

- Negative end reference cam

Parameter 9750.1 *Reference to zero pulse* (page 71) is set to "YES".

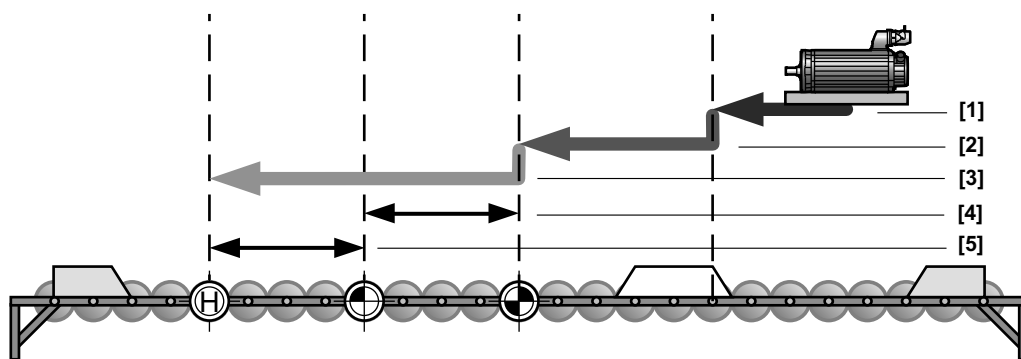

1240736139

- [1] 9731.3 Search velocity (page 72)
- [2] 9731.2 Clear velocity (page 72)
- [3] 9731.1 Start position velocity (page 72)
- [4] 9730.1 Reference offset (page 72)
- [5] 9730.2 Start position (page 72)

Parameter 9750.1 *Reference to zero pulse* (page 71) is set to "NO".

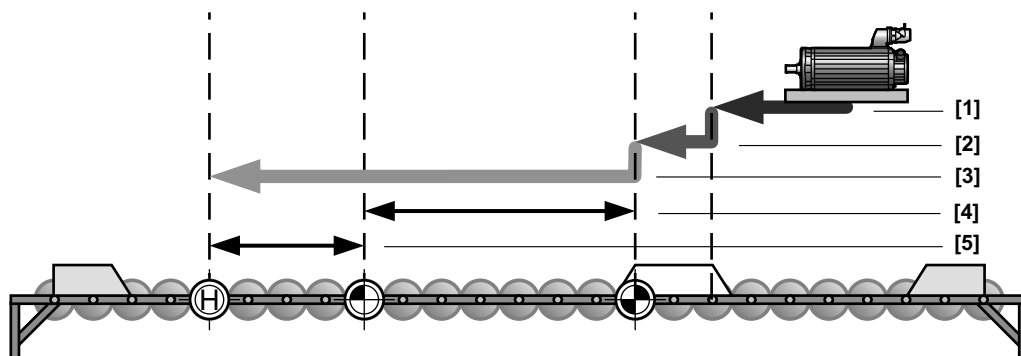

1240738571

- [1] 9731.3 Search velocity (page 72)
- [2] 9731.2 Clear velocity (page 72)
- [3] 9731.1 Start position velocity (page 72)
- [4] 9730.1 Reference offset (page 72)
- [5] 9730.2 Start position (page 72)

The reference position is the negative end of the reference cam or the first negative zero pulse after the end of the reference cam.

A bit in control word 0 – 3 must be set to "REFERENCE CAM".

kVA	n
	f
i	
P	H_z

The reference travel starts with the search velocity in a negative rotational direction up to the first positive edge of the reference cam. Search velocity changes to clear velocity once the reference cam is detected.

The reference point will then be the falling edge (negative end) of the reference cam without "Referencing to zero pulse". If "Referencing to zero pulse = yes", the reference point will be the first zero pulse after the falling edge of the reference cam.

Parameter 9657.1 *Hardware limit switch for velocity changeover* (page 72) is not relevant for this reference travel type.

- Positive end reference cam

Parameter 9750.1 *Reference to zero pulse* (page 71) is set to "YES".

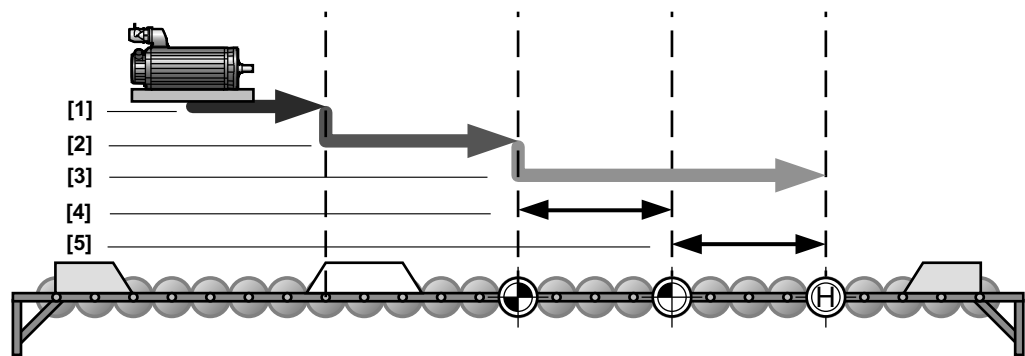

1240741387

- [1] 9731.3 Search velocity (page 72)
- [2] 9731.2 Clear velocity (page 72)
- [3] 9731.1 Start position velocity (page 72)
- [4] 9730.1 Reference offset (page 72)
- [5] 9730.2 Start position (page 72)

Parameter 9750.1 *Reference to zero pulse* (page 71) is set to "NO".

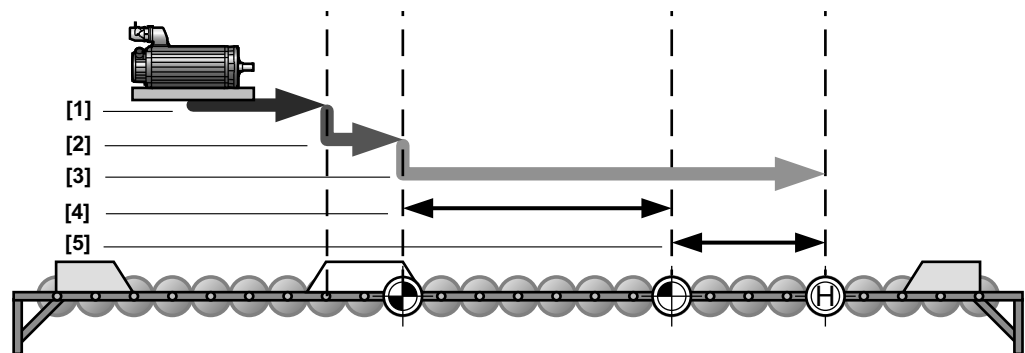

1240743819

- [1] 9731.3 Search velocity (page 72)
- [2] 9731.2 Clear velocity (page 72)
- [3] 9731.1 Start position velocity (page 72)
- [4] 9730.1 Reference offset (page 72)
- [5] 9730.2 Start position (page 72)

MX Parameter Description

Parameter description of drive data

The reference position is the positive end of the reference cam or the first positive zero pulse after the end of the reference cam.

A bit in control word 0 – 3 must be set to "REFERENCE CAM".

Reference travel starts in positive direction. The search velocity is used up to the first positive edge of the reference cam. Search velocity changes to clear velocity once the reference cam is detected.

The reference point will then be the falling edge (right end) of the reference cam without "Referencing to zero pulse". If "Referencing to zero pulse = yes", the reference point will be the first zero pulse after the falling edge of the reference cam.

Parameter 9657.1 *Hardware limit switch for velocity changeover* (page 72) is not relevant for this reference travel type.

- Limit switch positive

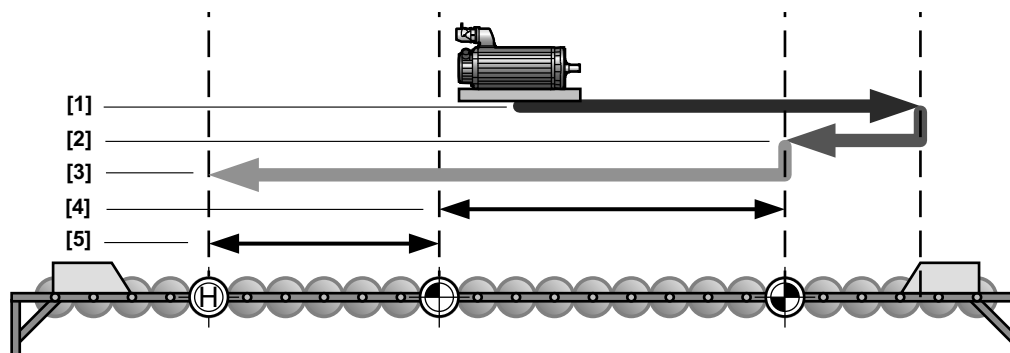

1240746251

- [1] 9731.3 Search velocity (page 72)
- [2] 9731.2 Clear velocity (page 72)
- [3] 9731.1 Start position velocity (page 72)
- [4] 9730.1 Reference offset (page 72)
- [5] 9730.2 Start position (page 72)

The reference position is the first zero pulse to the left of the positive limit switch.

Reference travel starts in positive direction. Search velocity is used up to the falling edge of the positive limit switch, then clear velocity is used.

Parameter 9657.1 *Hardware limit switch for velocity changeover* (page 72) is not relevant for this reference travel type.

kVA	n
f	
i	
P	Hz

- Limit switch negative

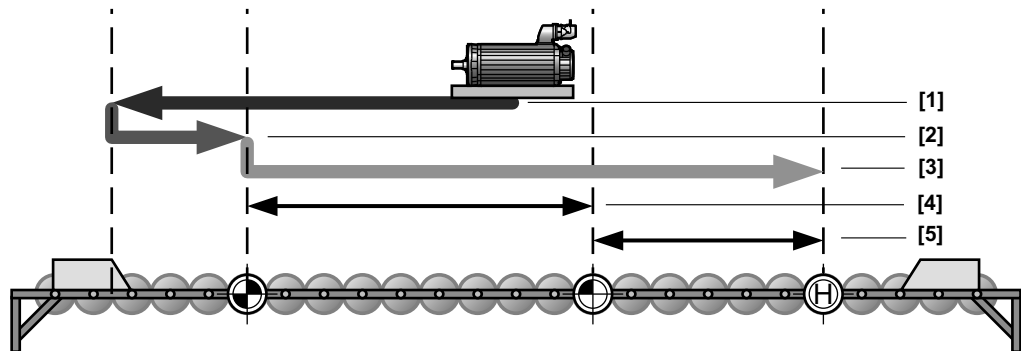

1240966283

- [1] 9731.3 Search velocity (page 72)
- [2] 9731.2 Clear velocity (page 72)
- [3] 9731.1 Start position velocity (page 72)
- [4] 9730.1 Reference offset (page 72)
- [5] 9730.2 Start position (page 72)

The reference point is the first zero pulse to the right of the negative limit switch.

Reference travel starts in negative direction. Search velocity is used up to the falling edge of the negative limit switch, then clear velocity is used.

Parameter 9657.1 *Hardware limit switch for velocity changeover* (page 72) is not relevant for this reference travel type.

- No reference travel

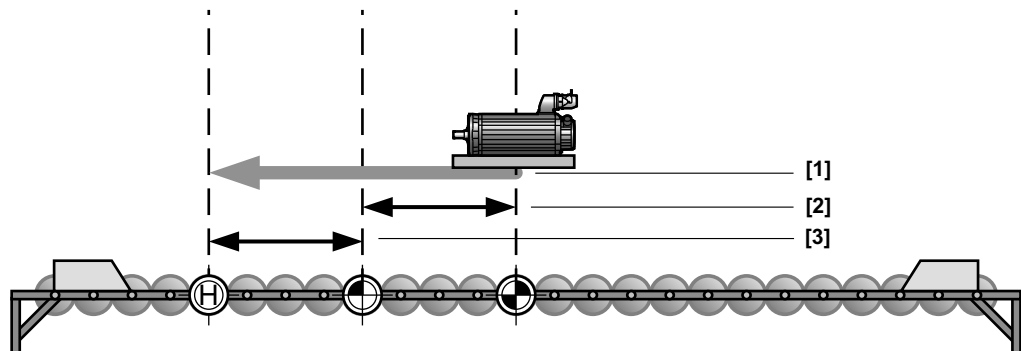

1240968715

- [1] 9731.1 Start position velocity (page 72)
- [2] 9730.1 Reference offset (page 72)
- [3] 9730.2 Start position (page 72)

The reference position is the current position. It makes sense to use this type of reference travel with absolute encoders and for drives that are to be referenced at standstill. For example, the position of a feed axis can be set to "zero" when the drive is at standstill. In this way, the machine operator can tell where the drive is located within each feed movement.

MX Parameter Description

Parameter description of drive data

- Reference cam flush with positive limit switch

Parameter 9750.1 Reference to zero pulse (page 71) is set to "YES".

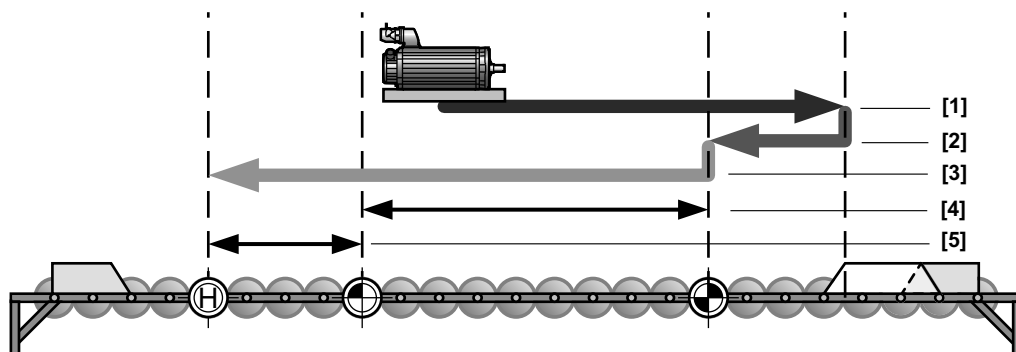

1240971147

- [1] 9731.3 Search velocity (page 72)
- [2] 9731.2 Clear velocity (page 72)
- [3] 9731.1 Start position velocity (page 72)
- [4] 9730.1 Reference offset (page 72)
- [5] 9730.2 Start position (page 72)

Parameter 9750.1 Reference to zero pulse (page 71) is set to "NO".

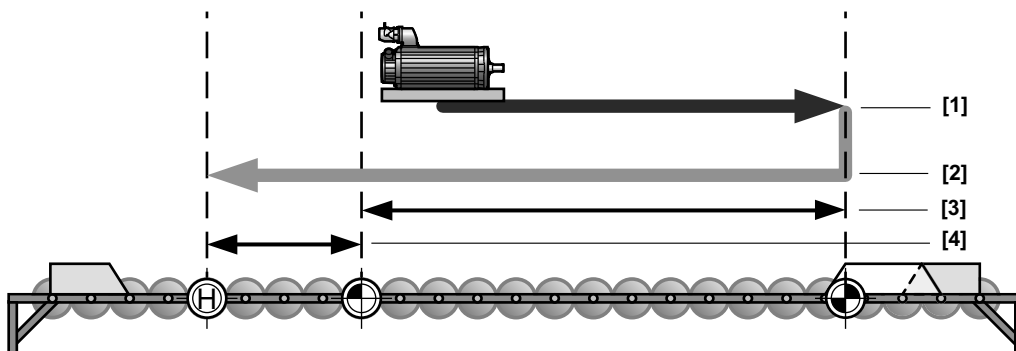

1240973579

- [1] 9731.3 Search velocity (page 72)
- [2] 9731.1 Start position velocity (page 72)
- [3] 9730.1 Reference offset (page 72)
- [4] 9730.2 Start position (page 72)

The reference position is the negative end of the reference cam or the first zero pulse to the left after the end of the reference cam.

A bit in control word 0 – 3 must be set to "REFERENCE CAM".

Reference travel starts in positive direction. Search velocity is used up to the first positive edge of the reference cam, then clear velocity is used. In contrast to the type "Negative end reference cam", the drive starts to the right and turns on the reference cam.

Depending on the setting "Reference to zero pulse", referencing takes place to the falling edge of the reference cam or to the zero pulse following the falling edge of the reference cam.

kVA	n
	f
i	
P	H _z

The reference cam must start just before or in line with the positive hardware limit switch and must project into the limit switch. This ensures that no hardware limit switch is hit during reference travel. Parameter 9657.1 *Hardware limit switch for velocity changeover* (page 72) is not relevant for this reference travel type.

- Reference cam flush with negative limit switch

Parameter 9750.1 *Reference to zero pulse* (page 71) is set to "YES".

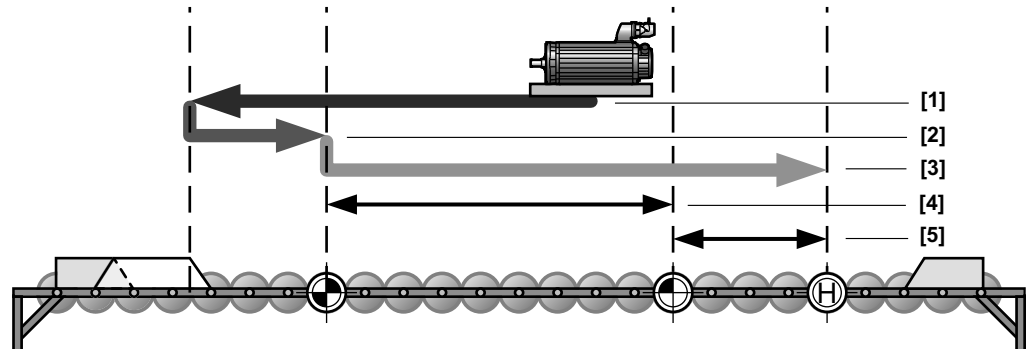

1240976907

- [1] 9731.3 Search velocity (page 72)
- [2] 9731.2 Clear velocity (page 72)
- [3] 9731.1 Start position velocity (page 72)
- [4] 9730.1 Reference offset (page 72)
- [5] 9730.2 Start position (page 72)

Parameter 9750.1 *Reference to zero pulse* (page 71) is set to "NO".

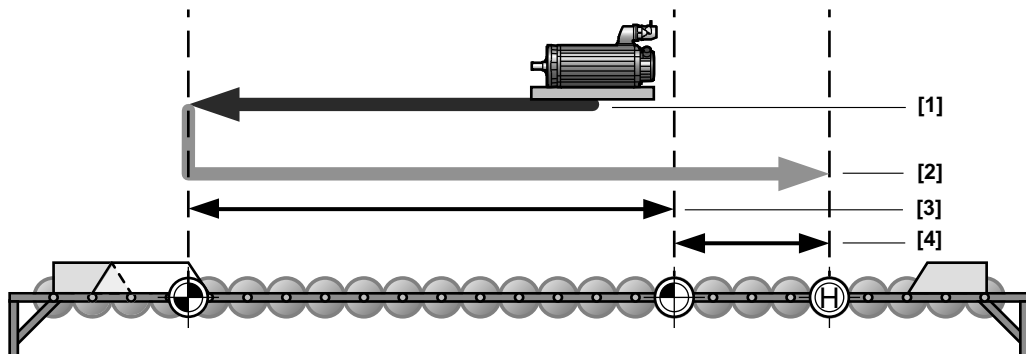

1241043339

- [1] 9731.3 Search velocity (page 72)
- [2] 9731.1 Start position velocity (page 72)
- [3] 9730.1 Reference offset (page 72)
- [4] 9730.2 Start position (page 72)

The reference position is the right end of the reference cam or the first zero pulse to the right after the end of the reference cam.

A bit in control word 0 – 3 must be set to "REFERENCE CAM".

kVA		n
	f	
i		
P	Hz	

MX Parameter Description

Parameter description of drive data

Reference travel starts in negative direction. Search velocity is used up to the first positive edge of the reference cam, then clear velocity is used. In contrast to the type "Positive end reference cam", the drive starts to the left and turns on the reference cam.

Depending on the setting "Reference to zero pulse", referencing takes place to the falling edge of the reference cam or to the zero pulse following the falling edge of the reference cam.

The reference cam must start just before or in line with the positive hardware limit switch and must project into the limit switch. This ensures that no contact is made with the hardware limit switch during reference travel.

Parameter 9657.1 *Hardware limit switch for velocity changeover* (page 72) is not relevant for this reference travel type.

- Fixed stop positive

Parameter 9657.1 *Hardware limit switch for velocity changeover* (page 72) is set to "Hardware limit switch".

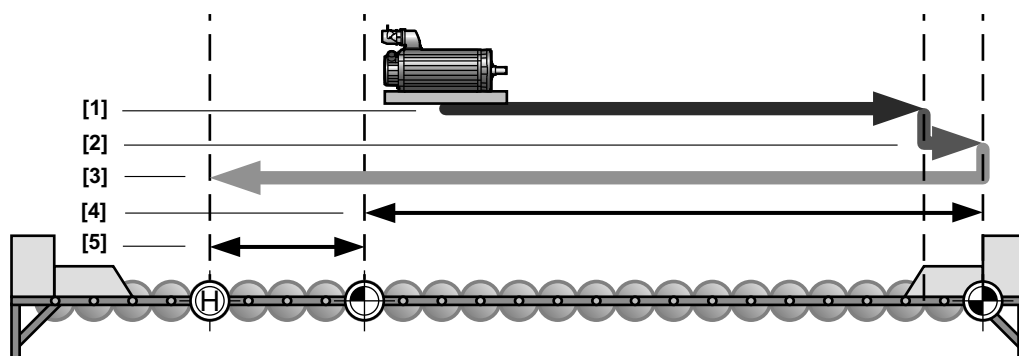

1241045771

- [1] 9731.3 Search velocity (page 72)
- [2] 9731.2 Clear velocity (page 72)
- [3] 9731.1 Start position velocity (page 72)
- [4] 9730.1 Reference offset (page 72)
- [5] 9730.2 Start position (page 72)

kVA	n
i	f
P	H _Z

Parameter "9657.1 Hardware limit switch for velocity changeover" (page 72) is set to "Reference cam".

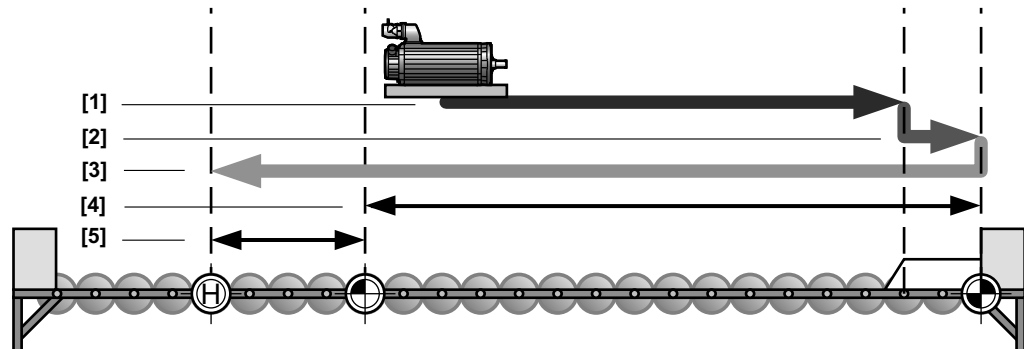

1241048203

- [1] 9731.3 Search velocity (page 72)
- [2] 9731.2 Clear velocity (page 72)
- [3] 9731.1 Start position velocity (page 72)
- [4] 9730.1 Reference offset (page 72)
- [5] 9730.2 Start position (page 72)

Parameter 9657.1 Hardware limit switch for velocity changeover (page 72) is set to "without".

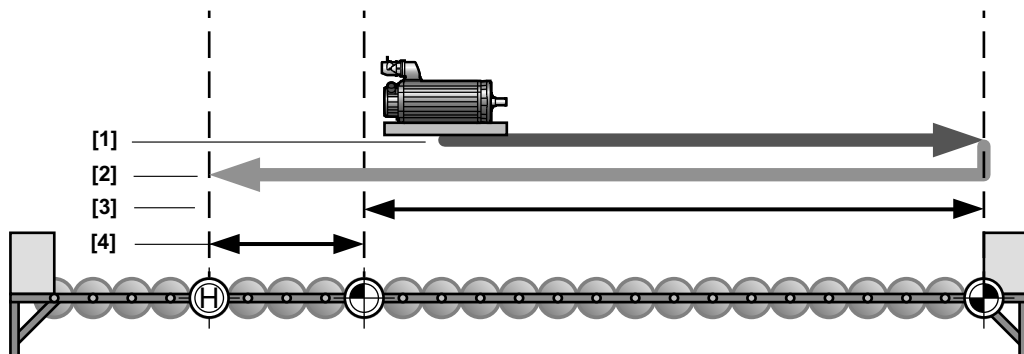

1242546699

- [1] 9731.2 Clear velocity (page 72)
- [2] 9731.1 Start position velocity (page 72)
- [3] 9730.1 Reference offset (page 72)
- [4] 9730.2 Start position (page 72)

The reference position is the positive fixed stop. The machine must be designed so that the fixed stop withstands impact at the corresponding speed without any damage.

Reference travel starts in positive direction. If parameter 9657.1 Hardware limit switch for velocity changeover (page 72) is set to "without", reference travel will start with clear velocity.

With the setting "Hardware limit switch" or "Reference cam", the reference travel starts with the search speed and reduces to the clear velocity when coming into contact with the hardware switch or reference cam.

MX Parameter Description

Parameter description of drive data

Parameter 9655.1 *Reference dwell time* (page 73) can be used to set the duration for which the torque (parameter 9654.4 *Torque reference travel* (page 73)) is maintained on the fixed stop until referencing.

- Fixed stop negative

Parameter 9657.1 *Hardware limit switch for velocity changeover* (page 72) is set to "Hardware limit switch".

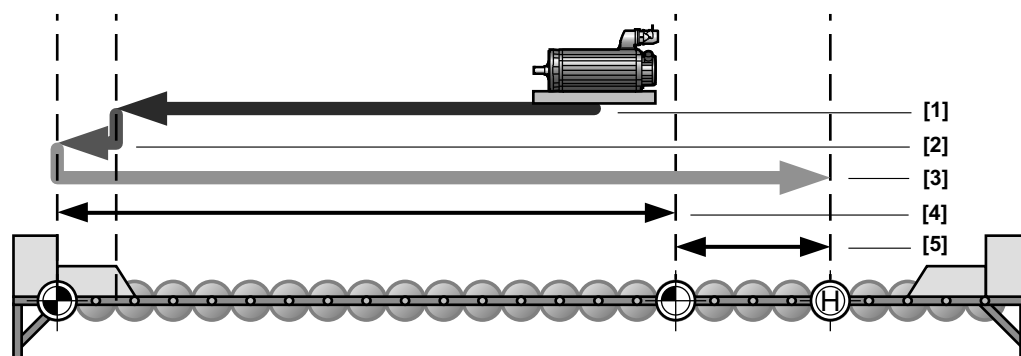

1242549131

- [1] 9731.3 Search velocity (page 72)
- [2] 9731.2 Clear velocity (page 72)
- [3] 9731.1 Start position velocity (page 72)
- [4] 9730.1 Reference offset (page 72)
- [5] 9730.2 Start position (page 72)

Parameter 9657.1 *Hardware limit switch for velocity changeover* (page 72) is set to "Reference cam".

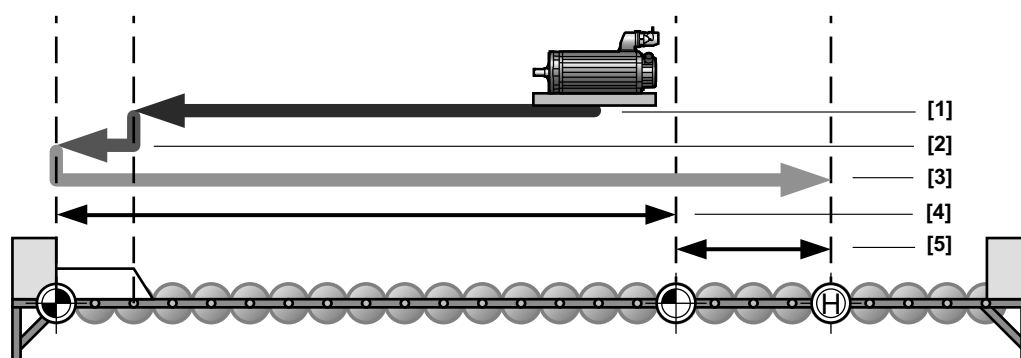

1242551819

- [1] 9731.3 Search velocity (page 72)
- [2] 9731.2 Clear velocity (page 72)
- [3] 9731.1 Start position velocity (page 72)
- [4] 9730.1 Reference offset (page 72)
- [5] 9730.2 Start position (page 72)

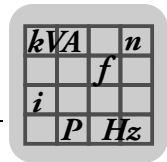

Parameter 9657.1 *Hardware limit switch for velocity changeover* (page 72) is set to "without".

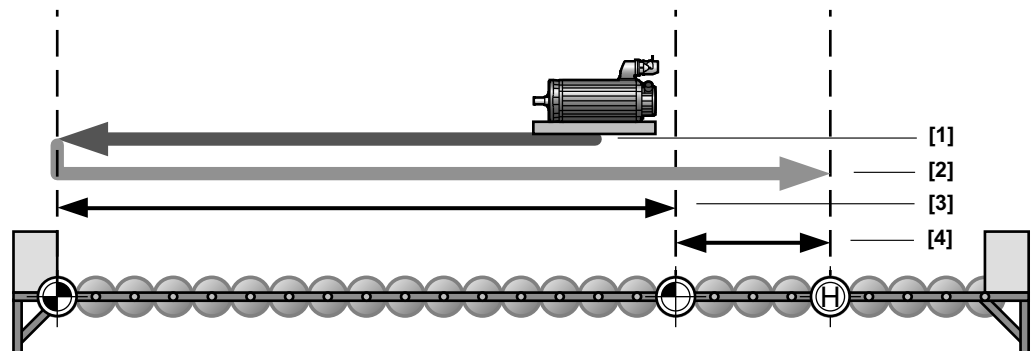

1242554251

- [1] 9731.2 Clear velocity (page 72)
- [2] 9731.1 Start position velocity (page 72)
- [3] 9730.1 Reference offset (page 72)
- [4] 9730.2 Start position (page 72)

The reference position is the negative fixed stop. The machine must be designed in such a way that it is not damaged when the fixed stop is reached at the respective speed.

Reference travel starts in negative direction. If parameter 9657.1 *Hardware limit switch for velocity changeover* (page 72) is set to "without", reference travel will start with clear velocity.

With the setting "Hardware limit switch" or "Reference cam", the reference travel starts with the search speed and reduces to the clear velocity when coming into contact with the hardware switch or reference cam.

Parameter 9655.1 *Reference dwell time* (page 73) can be used to set the duration for which the torque (parameter 9654.4 *Torque reference travel* (page 73)) is maintained on the fixed stop until referencing.

9750.1 / 10442.2 /
10443.2 *Referencing to zero pulse*

Value range:

- No
- Yes

Reference to zero pulse, see reference travel type parameter 9658.2 (page 59).

9656.1 / 10442.3 /
10443.3 *Travel to start position*

Value range:

- No
- Yes

Here is set whether the function "Travel to start position" is basically required.

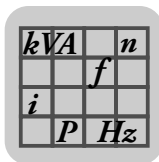

MX Parameter Description

Parameter description of drive data

<p>9657.1 / 10442.4 / 10443.4 HW limit switch for velocity changeover</p>	<p>Value range:</p> <ul style="list-style-type: none"> • <u>0 = Without</u> • 1 = Hardware limit switches • 2 = Reference cam <p>Hardware switch for velocity change during reference travel, see reference travel type parameter 9658.2 (page 59).</p>
<p>9730.2 / 10442.7 / 10443.7 Start position</p>	<p>Unit: U.</p> <p>Resolution: 1/65536.</p> <p>Value range: -2147483648 – 0 – 2147483647, step 1.</p> <p>Start position in user-defined units, see reference travel type parameter 9658.2 (page 59).</p>
<p>9730.1 / 10442.5 / 10443.5 Reference offset</p>	<p>Unit: U.</p> <p>Resolution: 1/65536.</p> <p>Value range: -2147483648 – 0 – 2147483647, step 1.</p> <p>Reference offset in user-defined units, see reference travel type parameter 9658.2 (page 59).</p>
<p>9730.3 / 10442.6 / 10443.6 Reference offset modulo</p>	<p>Unit: U.</p> <p>Resolution: 1/65536.</p> <p>Value range: -2147483648 – 0 – 2147483647, step 1.</p> <p>Reference offset modulo</p>
<p><i>Limit values</i></p> <p>9731.3 / 10442.8 / 10443.8 Search velocity reference speed 1</p>	<p>Unit: 10⁻³/min.</p> <p>Value range: 0 – 10000000, step 1.</p> <p>Search velocity in user-defined units (reference velocity 1), see reference travel type -parameter 9658.2 (page 59).</p>
<p>9731.2 / 10442.9 / 10443.9 Clear velocity reference speed 2</p>	<p>Unit: 10⁻³/min.</p> <p>Value range: 0 – 10000000, step 1.</p> <p>Clear velocity in user-defined units (reference velocity 2), see reference travel type -parameter 9658.2 (page 59).</p>
<p>9731.1 / 10442.10 / 10443.10 Start position reference speed 3</p>	<p>Unit: 10⁻³/min.</p> <p>Value range: 0 – 10000000, step 1.</p> <p>Start position velocity in user-defined units (reference velocity 3), see reference travel type parameter 9658.2 (page 59).</p>
<p>9654.1 / 10442.11 / 10443.11 Acceleration reference travel</p>	<p>Unit: 10⁻²/min×s.</p> <p>Value range: 0 – 300000 – 2147483647, step 1.</p> <p>Acceleration reference travel in user-defined units.</p>

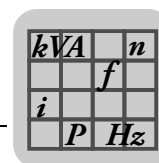

9654.2 / 10442.12 / 104432.12 Deceleration reference travel	Unit: 10 ⁻² /min×s. Value range: 0 – 300000 – 2147483647, step 1. Deceleration reference travel in user-defined units.
9654.3 / 10442.13 / 10443.13 Jerk reference travel	Unit: 1/(min×s ²). Value range: 1 – 2147483647, Step 1. Maximum jerk reference travel.
9654.4 / 10442.14 / 10442.14 Torque reference travel	Unit: %. Resolution: 10 ⁻³ . Value range: 0 – 100000 – 1000000, step 1. Torque limit reference travel in user-defined units.
9655.1 / 10442.15 / 10443.15 Reference dwell time fixed stop	Unit: ms. Value range: 0 – 100000, step 1. Reference dwell time fixed stop.

1.3 Communication parameter description

1.3.1 PDO Editor Process Data Object Editor

The PDO Editor is the central, graphical software tool for editing and configuring FCBs and the entire unit functionality.

The tool can be used to determine where and which data packages should be retrieved from buses or I/Os, how they should be interpreted (control/process data) and how they are used in the unit functions and, in the same way, to determine how this data is output (buses or I/O).

This feature makes for maximum flexibility when using the MOVIAXIS® functions without the user having to perform any programming. The graphical structure makes it easy for users to familiarize themselves with the tool using the intuitive interface.

1.3.2 Basic settings

9831.1 Stop process data	Value range: • <u>No</u> • Yes
--------------------------	--------------------------------------

Parameter changes that affect communication (all parameters described in the "Communication" section) will trigger error 66 and stop the process data. The parameter "Stop process data" = "YES" is also used to stop process data but no error message is generated.

The effect of parameter and error 66 is that the drive can only be enabled again when all parameters have been set and the drive does not rotate in a non-controlled manner at the upper speed limit.

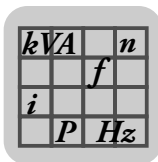

MX Parameter Description

Communication parameter description

9603.1 PDO
timeout response

Value range:

- 0 = No response
- 1 = Display only
- 5 = Output stage inhibit / waiting
- 6 = Emergency stop / waiting
- 8 = Stop at application limit / waiting
- 10 = Stop at system limit / waiting
- 17 = Stop at application limit / autoreset
- 18 = Emergency stop / autoreset
- 19 = Stop at system limit / autoreset
- 20 = Output stage inhibit / autoreset
- 21 = Stop at application limit / autoreset without fault memory
- 22 = Emergency stop / autoreset without fault memory
- 23 = Stop at system limit / autoreset without fault memory
- 24 = Output stage inhibit / autoreset without fault memory

The PDO timeout response sets the error response for the case that the IN buffer does not receive an expected process data. The process data was already received and is then absent before the error message is issued. The axis is in state C3 "Waiting for process data" after a reset. This is not an error but a state.

0 = No response:

Error is ignored

1 = Display only:

The 7-segment display shows the error but the axis does not respond (continues to operate).

5 = Output stage inhibit / waiting:

The axis changes to controller inhibit state and activates the mechanical brake, if installed. If no brake is installed, the motor will coast to a halt. After a reset, the axis performs a warm start. This means that the axis is immediately ready to operate again (without delay).

6 = Emergency stop / waiting:

The motor is stopped along the emergency stop ramp. After a reset, the axis performs a warm start. This means that the axis is immediately ready to operate again (without delay).

8 = Stop at application limit / waiting (default):

The motor is stopped at the application limit. After a reset, the axis performs a warm start. This means that the axis is immediately ready to operate again (without delay).

10 = Stop at system limit / waiting:

The motor is stopped at the system limit. After a reset, the axis performs a warm start. This means that the axis is immediately ready to operate again (without delay).

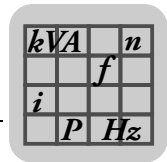

17 = Stop at application limit / autoreset

The motor is stopped at the application limit. The axis runs again without a reset when the error is no longer present.

18 = Emergency stop / autoreset

The motor is stopped at the emergency stop limit. The axis runs again without a reset when the error is no longer present.

19 = Stop at system limit / autoreset

The motor is stopped at the system limit. The axis runs again without a reset when the error is no longer present.

20 = Output stage inhibit / auto reset

The motor is stopped by the output stage inhibit. The axis runs again without a reset when the error is no longer present.

21 = Stop at application limit / autoreset without fault memory

The motor is stopped at the application limit. The axis runs again without a reset when the error is no longer present. Furthermore, no entry is generated in the error memory.

22 = Emergency stop / autoreset without fault memory

The motor is stopped at the emergency stop limit. The axis runs again without a reset when the error is no longer present. Furthermore, no entry is generated in the error memory.

23 = Stop at system limit / autoreset without fault memory

The motor is stopped at the system limit. The axis runs again without a reset when the error is no longer present. Furthermore, no entry is generated in the error memory.

20 = Output stage inhibit / auto reset without fault memory

The motor is stopped by the output stage inhibit. The axis runs again without a reset when the error is no longer present. Furthermore, no entry is generated in the error memory.

For more information, refer to the operating instructions section "Operation and Service".

9729.16 Response to external error

Value range:

- No response
- Display only
- Output stage inhibit/waiting
- Stop at application limit/waiting
- Stop at system limit/waiting

Descriptive text see parameter 9603.1 PDO timeout response (page 74)

This parameter sets the corresponding response if a bit was set to "External error" in control word 0 – 3.

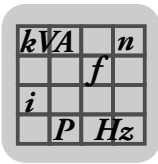

MX Parameter Description

Communication parameter description

Standard communication

8937.0 CAN1 protocol selection

Value range:

- 0=MOVILINK
- CANopen

CAN1 protocol selection.

8938.0 CAN2 protocol selection

Value range:

- 0=MOVILINK
- CANopen

CAN2 protocol selection.

8603.0 CAN1 baud rate

Value range:

- 0=125 kBaud
- 1=250 kBaud
- 2=500 kBaud
- 3=1 MBaud

CAN1 baud rate. This is only a display value. It is set using the automatic addressing function of the supply module.

8939.0 CAN2 baud rate

Value range:

- 0=125 kBaud
- 1=250 kBaud
- 2=500 kBaud
- 3=1 MBaud

CAN2 baud rate.

8600.0 CAN1 address

Value range: 0 – 63, step 1

Present CAN1 address. This is only a display value. It is set using the automatic addressing function of the supply module.

8932.0 CAN2 address

Value range: 0 – 99, step 1

CAN2 address

9825.1 Scope ID CAN1

Value range: 0 – 120 – 1073741823, step 1

This CAN message ID is used for all axis scope recordings (multi-axis scope).

9883.1 Synchronization ID CAN1

Value range: 0 – 128 – 1073741823, step 1

This synchronization ID is used for CAN1 for sending and receiving.

9882.1 Synchronization ID CAN2

Value range: 0 – 128 – 1073741823, step 1

This synchronization ID is used for CAN2 for sending and receiving.

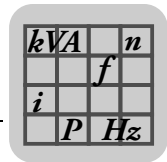

- 9877.5 Setpoint cycle CAN1** You can handle poorer sync messages (with large jitter) by increasing the CAN setpoint cycle. This is especially needed for baud rates below 500 kBaud.
The maximum sync jitter can be \pm (setpoint cycle CAN/4). Long-term deviation must not exceed an average of \pm 0.4 % of the CAN setpoint cycle.
The CAN setpoint cycle can be increased if the controller cannot maintain the tolerance of the sync. The value must be a whole-number multiple of the sync cycle.
The default value of "1 ms" is the optimum setting for axis-axis communication within MOVIAXIS® and a minimum baud rate of 500 kBaud.
- 9878.5 Setpoint cycle CAN2** Descriptive text see parameter *9877.5 Setpoint cycle CAN1* (page 77).
- 10118.1 Sync mode CAN1** Value range:
 - 0=Consumer
 - 1=Producer
 Is used to set whether the axis receives (consumes) or sends (produces) a synchronization protocol on CAN1.
 Observe the parameter *9836.1 Synchronization source* (page 80) when setting "Consumer".
 Observe the parameters "*9877.1 Sync period* (page 77), *9877.2 Sync offset* (page 78) and *9877.3 Sync start mode* (page 78)" when setting "Producer".
- 10118.2 Sync mode CAN2** Value range:
 - 0=Consumer
 - 1=Producer
 Is used to set whether the axis receives (consumes) or sends (produces) a synchronization protocol on CAN2.
 Observe the parameter *9836.1 Synchronization source* (page 80) when setting "Consumer".
 Observe the parameters *9878.1 Sync period* (page 77), *9878.2 Sync offset* (page 78) and *9878.3 Sync start mode* (page 79) when setting "Producer".
- 9877.1 Sync period CAN1** Unit: μ s
 Value range: 0 – 5000 – 100000000, step 1000
 Sync period CAN1.
 Only if *10118.1 Sync mode CAN1* (page 77) is set to "Producer".
- 9878.1 Sync period CAN2** Unit: μ s
 Value range: 0 – 5000 – 100000000, step 1000
 Sync period CAN2.
 Only if *10118.2 Sync mode CAN2* (page 77) is set to "Producer".

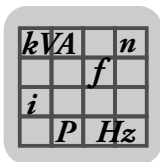

MX Parameter Description

Communication parameter description

- 9877.2 Sync offset CAN1** Unit: μs
 Value range: 0 – 5000 – 100000000, step 1000
 Sync offset CAN1.
 Only if *10118.1 Sync mode CAN1* (page 77) is set to "Producer".
 The offset causes a start delay on the parameter *9877.3 Sync start mode CAN1* (page 78).
- 9878.2 Sync offset CAN2** Unit: μs
 Value range: 0 – 5000 – 100000000, step 1000
 Sync offset CAN2.
 Only if *10118.2 Sync mode CAN2* (page 77) is set to "Producer".
- 9877.3 Sync start mode CAN1** Value range:
- 0 = Off
 - 1 = when receiving PDO00
 - 2 = PDO01
 - 3 = PDO02
 - 4 = PDO03
 - 5 = PDO04
 - 6 = PDO05
 - 7 = PDO06
 - 8 = PDO07
 - 9 = PDO08
 - 10 = PDO09
 - 11 = PDO10
 - 12 = PDO11
 - 13 = PDO12
 - 14 = PDO13
 - 15 = PDO14
 - 16 = PDO15
 - 100 = Direct
- The sync start mode CAN1 describes when the axis should start with the sync protocols.
- OFF**
 No sync protocols are sent. The module is disabled.
- PDO00 to PDO15**
 The synchronization protocols are started if the corresponding PDO00 to PDO15 was received once.
- Direct**
 The synchronization protocols are started immediately after booting.

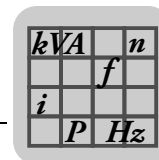

- 9878.3 Sync start mode CAN2** Sync start mode CAN2.
See parameter **9877.3 Sync start mode CAN1** (page 78).
- 9992.1 Sync jitter compensation CAN1** Value range:
- No
 - Yes
- The sync jitter compensation function informs the sync protocol how much later it can place the sync protocol on the CAN. There are always delays if another protocol is being processed during sync (approx. 200 µs).
- The receiver will process this offset.
- This is a SEW particularity and always has to be set when MOVIAXIS® units are sync master and sync slave in relation to one another. In this case, the sync jitter compensation for the two other units must be set to "YES".
- With external sync master, the sync jitter compensation must be set to "NO".
- 9993.1 Sync jitter compensation CAN2** Value range:
- No
 - Yes
- CAN2 sync jitter compensation.
See parameter **9992.1 Sync jitter compensation CAN1** (page 79)
- Communication option**
- 8453.0 Fieldbus baud rate** Value range: 0 – 4294967295, step 1
- The baud rate of the fieldbus is specified by the master depending on the fieldbus type. In some cases this is only a display value (e.g. PROFIBUS) or an input value.
- 8454.0 Fieldbus address** Value range: 0 – 4294967295, step 1
- Current fieldbus address (e.g. for PROFIBUS this is a hardware setting on the option card). In some cases this is only a display value or an input value, just like the fieldbus baud rate.
- 8606.0 Timeout** Unit: ms
- Value range: 0 – 500 – 650000, step 10
- Fieldbus timeout interval.
- An error will be triggered after this timeout interval when the fieldbus is interrupted.
- 9729.17 Fieldbus timeout response** Value range: See parameter **9729.16 Response external error** (page 75).
- Fieldbus timeout response.
- For a description of the setting options, see parameter "**9603.1 PDO timeout response**" (page 74).

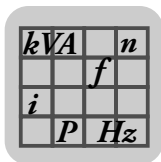

MX Parameter Description

Communication parameter description

Gateway

9879.1 Sync
period gateway

Unit: μs

Value range: 0 – 5000 – 100000000, step 1000

Sync period gateway.

This value is used for transferring the sync signal from the fieldbus to the system bus. This currently works only with the K-Net fieldbus. In case of questions please contact SEW-EURODRIVE.

9879.2 Sync offset
gateway

Unit: μs

Value range: 0 – 5000 – 100000000, step 1000

Sync offset gateway.

This value is used for transferring the sync signal from the fieldbus to the system bus. This currently works only with the K-Net fieldbus. In case of questions please contact SEW-EURODRIVE.

9879.3 Sync start
mode gateway

Value range: See parameter 9877.3 Sync start mode CAN1

Sync start mode gateway.

This value is used for transferring the sync signal from the fieldbus to the system bus. This currently works only with the K-Net fieldbus. In case of questions please contact SEW-EURODRIVE.

Synchronization

9836.1 Synchroni-
zation source

Value range:

- 0=No source
- 1=CAN2
- 2=CAN1
- 3=Communication option

If the CAN1 or CAN2 sync mode is set to consumer, then this parameter sets the source of the sync signal.

9835.1 Time inter-
val between sync
signals

Unit: μs

If the axis is the consumer of a sync signal, all incoming signals will be recorded with respect to time and displayed here.

9951.4 Time inter-
val between base
periods

Value range: -2147483648 – 0 – 2147483647, step 1

For in-house use only!

The time interval between base periods is a display value for internal error diagnostics purposes. All other tasks are derived from the base period.

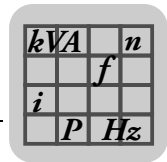

1.3.3 IN buffer



1242563979

IN buffer 0

Basic settings

9514.1 Data source

Value range:

- 0=No source
- 1=CAN2
- 2=CAN1
- 3=Communication option

The setting in the data source defines the bus system responsible for reading the data.

9514.3 Data block start

The data block start describes from which data block within a message the IN buffer is loaded. Whether a value unequal to 0 may be entered depends on the bus system (e.g. the data block start for CAN is always 0).

9514.4 Data block length

Value range: 0 – 4 – 16, step 1.

The data block length also depends on the bus system, e.g. for CAN = maximum 4.

9514.19 Timeout interval

Unit: μ s

Value range: 0 – 100000000, step 1000.

Timeout interval IN buffer 0. The value 0 deactivates the timeout.

9514.5 Update

Value range:

- 1=ON
- 0=OFF

The update indicates whether the value in the IN buffer is updated with the values from the bus or not. This parameter can be used to separate the PDO from the bus.

9514.16 Configuration error

Value range: 0 – 4294967295, step 1

- 0=No error

The config error indicates any error.

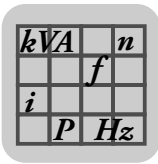

MX Parameter Description

Communication parameter description

Specific CAN parameters

9514.2 Message ID Value range: 0 – 1073741823, step 1
The message ID is a CAN-specific parameter. It numbers or prioritizes the messages.

9514.14 Data acceptance with sync. Value range:

- 1=No
- 0=Yes

 Here you can set whether the data is transferred to the IN buffer after receiving the first sync message. This is a CAN-specific parameter.

	INFORMATION
	The sync must be sent exactly as often as the process data when set to "Yes".

9514.20 Endianness IN buffer 0 Value range:

- 0=Big Endian
- 1=Little Endian

 This parameter is used to set whether the first of the two bytes from the bus is interpreted as high or low byte.

- **Big Endian**
The first byte from the bus is interpreted as high byte.
- **Little Endian**
The first byte from the bus is interpreted as low byte.

 This is a CAN-specific parameter.

Specific communication option parameters

9514.18 Address sender IN buffer 0 Value range: 0 – 255, step 1.
This parameter only applies to the K-Net bus system and sets the PDO address. This parameter is usually set in the PDO Editor.

9514.17 PDO ID Value range: 0 – 255, step 1.
K-Net IN buffer ID 0.

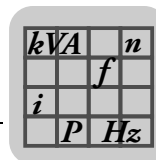

Data

9754.1 – 16 data Value range: 0 – 65535, step 1.
word 0 – 15 Data word 0 – 15 IN buffer 0.
Displays the current data in the IN buffer 0 – 15.

IN buffer 1 – 15 See IN buffer 0 (page 81) for a description of the parameter.

1.3.4 Control words 0 – 3

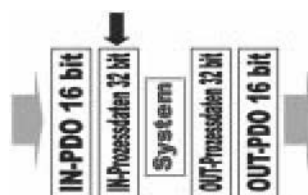

1242556683

9510.1 Actual value source Displays the actual value of control word 0.

Control word 0 The control word is the control center that activates or deactivates functions in the axis module via binary inputs or process data.

9512.1 Source control word 0 Value range:

- 0=No source
- 8334=Standard binary inputs
- 75339=Local control word
- 730515=Opt 1 DI
- 730521=Opt 2 DI
- Or "IN 0-15" word 0 – 15

Several sources can be set for control word 0:

• **No source**

The control word is inactive.

• **Standard binary inputs**

The binary inputs on the basic unit are transferred to the control word. All FCBs 1 = active via bus communication (1 on FCB 13 triggers a stop at the application limits). To implement wire breakage protection via binary inputs, the following FCBs or functions are 0 = active:

- FCB 01 Output stage inhibit
- FCB 13 Stop at application limits
- FCB 14 Emergency stop
- FCB 15 Stop at system limits

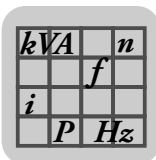

MX Parameter Description

Communication parameter description

- External error (no FCB but message)
- Limit switch positive
- Limit switch offset (0 on FCB 13 negative triggers a stop at the application limits). This only applies to the standard binary input source.

- **Local control word**

Parameter *9803.1 Local value* (page 84) specifies the control word.

- **Opt 1 DI**

If a digital terminal expansion XIO or XIA is plugged in option slot 1, then the control word is specified by the option.

- **Opt 2 DI**

If a digital terminal expansion XIO or XIA is plugged in option card slot 3, the control word is specified by the option.

- **IN**

If you want to specify the control word via bus, set IN 0 – 15 and word 0 – 15.

This parameter is usually set in the PDO Editor.

9803.1 Local value Value range: 0 – 4294967295, step 1

If the source control word 0 is set to "local control word", this parameter will be control word 0. This must only be used for test purposes, as the parameter is set to 0 after a reset.

This parameter is usually set in the PDO Editor.

9513.1 Layout Value range:

- 0=No layout
- 1=Programmable layout
- 2 = FCB/ instance
- 3 = Programmable layout / FCB / instance

Layout control word 0

- **No layout**

The control word is inactive.

- **Programmable layout**

Each bit of the control word is freely configurable.

- **FCB/instance**

The control word has a fixed assignment. The 8 low bits (low byte) are used for selecting the FCB and the 8 high bits (high byte) for selecting the instance. See also parameter "9804.1 Select FCB with instance".

- **Programmable layout / FCB / instance**

Part of the control word has a fixed assignment. Bit 0 to 4 is freely configurable: Bits 5 to 9 selects the FCB. Bits 10 to Bit 15 select the instance.

This parameter is usually set in the PDO Editor.

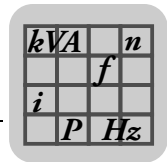

9513.10 Bit 0

Value range:

- 0 = No function
- 1 = FCB final stage lock
- 2 = FCB stop at system limits
- 3 = FCB emergency stop
- 4 = FCB stop at application limits
- 5 = FCB reference travel
- 7 = FCB jog mode
- 8 = FCB hold control
- 9 = FCB brake test
- 10 = FCB encoder adjustment
- 11 = FCB electronic gear unit
- 12 = FCB electronic cam
- 13 = FCB interpolated position control
- 14 = FCB positioning
- 15 = FCB interpolated speed control
- 16 = FCB speed control
- 17 = FCB interpolated torque control
- 18 = FCB torque control
- 20 = FCB rotor position identification
- 21 = FCB stop at user limits
- 31 = Limit switch 1 positive
- 32 = Limit switch 1 negative
- 33 = External error
- 34 = Fault reset
- 35 = Reference cam
- 36 = Parameter selection bit 0
- 37 = Parameter selection bit 1
- 38 = IEC input
- 39 = Jog negative
- 40 = Jog positive
- 41 = Feed enable
- 42 = Accept position
- 46 = Limit switch 2 positive
- 47 = Limit switch 2 negative
- 48 = Limit switch 3 positive
- 49 = Limit switch 3 negative

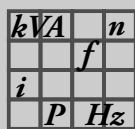

MX Parameter Description

Communication parameter description

- 50 = Start synchronous operation
- 51 = Event control FCB reset
- 52 = Jog velocity selection
- 53 = Release brake with inhibited output stage
- 54 = Control bit stop with position control

Programmable control word 0 layout bit 0.

Determines the function of bit 0 of control word 0.

- **No function**

The bit is inactive.

- **FCBs**

Activating the bit selects the corresponding FCB. The corresponding FCB is active if "1" is present. The only exception is if binary inputs are the source of the control word. The stop FCB 0 is then active for wire breakage protection. See also parameter "9512.1 Source control word 0" (page 83).

- **Limit switch**

Via binary inputs:

Signal 0 → Positive limit switch reached

Signal 1 → Limit switch not approached

Via IN buffer:

Signal 0 → Limit switch not approached

Signal 1 → Positive limit switch reached

- **External error**

Signal 0 → External error is present

Signal 1 → External error not present → enable

- **Error reset**

The axis is performing an error reset. A CPU reset, system restart or warm start is performed depending on the type of error. An error of the type display only (warning) will also be reset.

- **Reference cam**

Is required for reference travel.

- **Parameter selection bit 0**

Selecting another parameter set switches to a second or third connected motor. For this purpose, the motors have to be specified in the startup routine.

Bit 0 = 0 and bit 1 = 0 → No function

Bit 0 = 1 and bit 1 = 0 → motor 1

Bit 0 = 0 and bit 1 = 1 → motor 2

Bit 0 = 1 and bit 1 = 1 → motor 3

- **Parameter selection bit 1**

See parameter selection bit 0

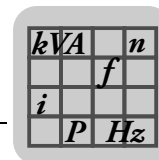

- **IEC input**

This bit can be used for a master MOVI-PLC®.

- **Jog negative**

This bit is only active in conjunction with *FCB 20 Jog* (page 153) active and jogging occurs in the corresponding direction when a "1" is present at the input.

- **Jog positive**

This bit is only active in conjunction with *FCB 20 Jog* (page 153) active and jogging occurs in the corresponding direction when a "1" is present at the input.

- **Jog velocity selection**

Switching between jog speeds 1 and 2.

- **Feed enable**

This bit is only active in conjunction with *FCB 09 positioning* (page 134). If you have selected feed enable, it must be set to "1" during the entire positioning procedure. Revoking feed enable will decelerate the axis using the maximum deceleration of *FCB 09 Positioning* (page 134). Another enable continues the positioning travel to the last target at the acceleration specified in *FCB 09 Positioning* (page 134). Feed enable must be activated in parameter *9885.1 Use control bit "feed enable"* (page 135).

- **Accept position**

This bit is only active in conjunction with *FCB 09 Positioning* (page 134) and is particularly useful for relative operating modes. This bit must have received a positive edge once in order to trigger the positioning process. This can be used to relatively synchronize forward without changing the target. This function is also effective in absolute operating modes. Accepting the position must be activated in parameter *9885.2 Control bit "accept -position"* (page 135).

- **Event control FCB reset**

This bit resets a FCB selection of event processing for the duration of the bit selection. For information about event control, refer to the MOVIAXIS® technology manual.

This parameter is usually set in the PDO Editor.

- **Release brake with inhibited output stage**

This bit releases the brake within the *FCB 01 Output stage inhibit*. This function is edge-triggered, i.e. the brake is only released with a positive edge while *FCB 01 Output stage inhibit* has already been selected.

9513.xx Bit 1 – 15 See description of parameter *9513.xx Bit 0*.

9510.1 Actual value source Displays the current control word 0.

Control word 1 See control word 0 (page 83) for a description of the parameter.

Control word 2 See control word 0 (page 83) for a description of the parameter.

Control word 3 See control word 0 (page 83) for a description of the parameter.

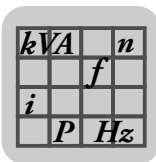

1.3.5 Error message words

Error message word can forward error states across different axes. For example, an error in the main drive can cause all auxiliary drives to go to error status. This is realized via lateral axis communication and for this reason only possible with the CAN system bus.



1242556683

9979.1 Source error message word 0

Value range:

- 0=No source
- 8334=Standard binary inputs
- 75339=Local control word
- 730515=Option 1
- 730521=Option 2
- Or "IN buffer 0 – 15" word 0 –15

This parameter is usually set in the PDO Editor.

9977.1 Response error message word 0

Value range:

- No response
- Display only
- Stop at application limit/waiting
- Emergency stop / waiting
- Stop at system limit/waiting
- Output stage inhibit/waiting
- System-internal/waiting (no function)

The error message word response defines the response upon receiving an error message.

This parameter is usually set in the PDO Editor.

9978.1 Response error message word 0

The error message word is triggered when the high byte of the current value is not equal to zero. This allows for direct transmission of a status word of another axes with the layout *FCB Error code*.

This parameter is usually set in the PDO Editor.

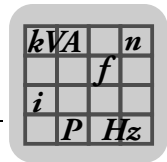

1.3.6 IN process data



1242556683

Channel 0

9822.1 Source process data channel 0

Value range:

- 0=No source
- 8334=Standard binary inputs
- 75339=Local control word
- 730515=Option 1
- 730521=Option 2
- Or "IN buffer 0 – 15" word 0 –15

Source of the IN process data channel 0

This parameter is usually set in the PDO Editor.

9530.1 Access channel 0 32-bit

Value range:

- 0=16-bit
- 1=32 Bit Big Endian
- 2=32 Bit Little Endian

IN process data channel 0 access 32 bit.

- **16 bit**

Access to the value set in parameter 9822.1 Source process data channel 0 (page 89) is transferred.

- **32 Bit Big Endian**

The access to the value set in parameter 9822.1 Source process data channel 0 (page 89) is accepted as high word (16 high bits) and and source +1 as low word.

For example: IN BUFFER 1 set as source.

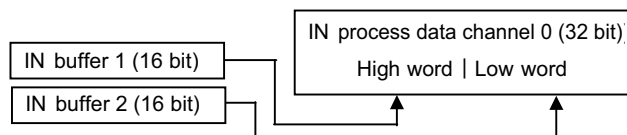

1242559115

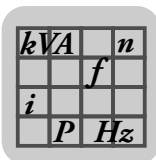

MX Parameter Description

Communication parameter description

- **32 Bit Little Endian**

The access to the value set in parameter *822.1 Source process data channel 0* (page 89) is accepted as low word (16 high bits) and and source +1 as high word.

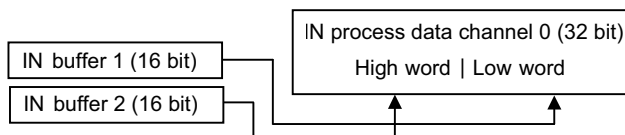

1242561547

This parameter is usually set in the PDO Editor.

9531.1 System unit channel 0

Value range:

- 0=Position
- 1=Speed
- 2=Acceleration
- 3=Torque
- 4=Not interpreted
- 5=System position

The system unit selection has to be set to specify the interpretation of channel 0 (what numerator / denominator factor should be used) so that the IN process data channels can be processed as user-defined units in the system.

This parameter is usually set in the PDO Editor.

9876.1 Actual value channel 0

Value range: -2147483648 – 0 – 2147483648, step 1.

The actual value of the IN process data channel 0 has a size of 32 bits in user-defined units.

This parameter is usually set in the PDO Editor.

Channel 1 – 15

9822.2 – 16 Source process data channel 1

Value range: See parameter *9822.1 Source process data channel 0* (page 89).

9530.2 – 16 Access channel 1 – 15 32-bit

Value range: See parameter *9530.1 Access channel 0 32-bit* (page 89).

9531.2 – 16 System variable channel 1 – 15

Value range: See parameter *9531.1 Channel 0 system variable* (page 90).

9876.2 – 16 Actual value

Value range: -2147483648 – 0 – 2147483647, step 1.

The actual value of IN process data channel 1 has a size of 32 bits in user-defined units.

This parameter is usually set in the PDO Editor.

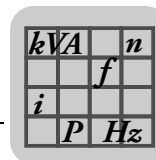

1.3.7 Status words 0 – 3

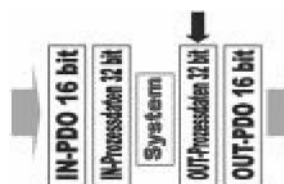

1242771211

Status word 0

9511.1 Actual value Value range: 0 – 4294967295, step 1.
Displays the current value of status word 0.

Basic settings

9851.1 Source Value range:

- 0=No source
- 1=System
- 2=Local status word

Several sources can be set for status word 0:

- **No source**
The status word is inactive.
- **System**
The status word is composed of system variables that are based on the parameter *9856.1 Layout and function* (page 92).
- **Local control word**
Parameter *9844.1 Local value* (page 91) specifies the status word.
This parameter is usually set in the PDO Editor.

9844.1 Local value Value range: 0 – 65535, step 1.
If the status word 0 source is set to "local control word", this parameter will be status word 0. This must only be used for test purposes, as the parameter is set to 0 after a reset.
This parameter is usually set in the PDO Editor.

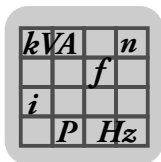

MX Parameter Description

Communication parameter description

9856.1 Layout

Value range:

- 0 = Programmable layout
- 1 = FCB/ instance
- 2 = FCB / error code
- 3 = Programmable layout / error code

Layout status word 0

- **No layout**

The status word is inactive

- **Programmable layout**

Each bit of the status word is freely configurable.

- **FCB/instance**

The status word has a fixed assignment. The 8 low bits (low byte) are used for displaying the currently active FCB and the 8 high bits (high byte) for displaying the currently active instance.

- **FCB/error code**

The status word has a fixed assignment. The 8 low bits (low byte) are used for displaying the currently active FCB and the 8 high bits (high byte) for displaying the current error. If the axis is not in error status, a 0 will be displayed in the upper error byte.

- **Programmable layout / error code**

The status word only has partial fixed assignment. The lower 8 bits (low byte) are freely configurable. The upper 8 bits (high byte) have fixed assignment with the error code in the event of an error.

This parameter is usually set in the PDO Editor.

Programmable layout

9559.1 Bit 0

Value range:

- 0=No function
- 1=Ready for operation
- 2=Output stage ON
- 3=Brake released
- 4=Brake applied
- 5=Motor standstill
- 6=Negative limit switch
- 7=Positive limit switch
- 8=Drive 1 referenced
- 9=Drive 2 referenced
- 10=Drive 3 referenced
- 11=Active drive referenced

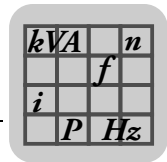

- 12=In position
- 13=Parameter set bit 0
- 14=Parameter set bit 1
- 15=Setpoints active
- 16=Torque limit reached
- 17=Current limit reached
- 18=IEC control error
- 19=IEC output
- 20=Fault
- 21=Displayed fault signal
- 22=Error without immediate output stage inhibit
- 23=Error with immediate output stage inhibit
- 24=FCB speed control active
- 25=FCB interpolated speed control active
- 26=FCB torque control active
- 27=FCB interpolated torque control active
- 28=FCB positioning active
- 29=FCB interpolated positioning active
- 30=FCB electronic gear unit
- 31=FCB hold control active
- 32=FCB jog mode active
- 33=FCB brake test function active
- 34=Calibrate FCB encoder
- 36=FCB electronic cam active
- 37=FCB Output stage inhibit active
- 38=FCB system stop active
- 39=FCB emergency stop active
- 40=FCB application stop active
- 41=FCB standard (FCB13)
- 42=Safe stop 1
- 43=Safe stop 2
- 44=Prewarning motor temperature (KTY)
- 45=FCB dual drive active
- 46=External fault reset
- 47=Software limit switch positive
- 48=Software limit switch negative

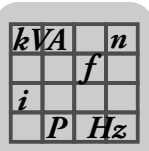

MX Parameter Description

Communication parameter description

- 49=Process data valid (no function)
- 51=Brake tested OK
- 52=Brake tested not OK
- 53=DI-00 output stage enable
- 54 = FCB 25 Rotor position identification active
- 55 = FCB 26 Stop at user limits active
- 56 = FCB 26 Stop at user limits position controlled
- 57 = Motor commutated
- 58 = 24 V standby operation
- 59 = Process data not ready

Programmable status word 0 layout bit 0.

- **No function**

The bit is inactive.

- **Ready**

Signal 0 → The axis is currently not ready for operation. Reasons can be error states or operating states outside FCB processing (supply voltage off, supply module not ready).

Signal 1 → The axis is in FCB processing. If no FCB is selected, the default FCB 13 Stop at application limits will be active. The 7-segment display will show the number 13.

- **Output stage ON**

"Output stage enabled" is a subset of "Ready for operation" which is set to "1" in all FCBs except for FCB 01 Output stage inhibit.

- **Brake released**

Signal 0 → Brake output activated

Signal 1 → Brake output not activated

- **Brake applied**

Signal 0 → Brake output not activated

Signal 1 → Brake output activated

- **Motor standstill**

Signal 0 → Motor is turning

Signal 1 → Motor at standstill

The threshold from which motor standstill is indicated as such is set in parameters

– 10056.1 *Velocity threshold motor at standstill - status bit* (page 47)

– 10057.1 *Filter time motor at standstill - status bit* (page 47)

.

- **Limit switch negative**

Signal 0 → Limit switch not approached

Signal 1 → Limit switch approached

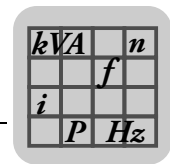

- **Limit switch positive**

Signal 0 → Limit switch not approached

Signal 1 → Limit switch approached

- **Axis 1 referenced**

This bit indicates whether axis 1 (parameter set 1) is referenced. Incremental encoders, resolvers and single-turn Hiperface® encoders lose their reference with each power-off. Absolute encoders must be referenced only once before use, or after a reset to the delivery state (parameter 9727.3 *Delivery state d1* (page 173)). An additional function is integrated in motors with Hiperface® encoders. In case of service a new motor is recognized and the referenced bit is reset.

- **Axis 2 referenced**

This bit indicates whether axis 2 (parameter set 2) is referenced. Incremental encoders, resolvers and single-turn Hiperface® encoders lose their reference with each power-off. Absolute encoders must be referenced only once before use, or after a reset to the delivery state (parameter 9727.3 *Delivery state d1* (page 173)). An additional function is integrated in motors with Hiperface® encoders. In case of service a new motor is recognized and the referenced bit is reset.

- **Axis 3 referenced**

This bit indicates whether axis 3 (parameter set 3) is referenced. Incremental encoders, resolvers and single-turn Hiperface® encoders lose their reference with each power-off. Absolute encoders must be referenced only once before use, or after a reset to the delivery state (parameter 9727.3 *Delivery state d1* (page 173)). An additional function is integrated in motors with Hiperface® encoders. In case of service a new motor is recognized and the referenced bit is reset.

- **Active drive referenced**

This bit indicates whether the active axis is referenced. Incremental encoders, resolvers and single-turn Hiperface® encoders lose their reference with each power-off. Absolute encoders must be referenced only once before use, or after a reset to the delivery state (parameter 9727.3 *Delivery state d1* (page 173)). An additional function is integrated in motors with Hiperface® encoders. In case of service a new motor is recognized and the referenced bit is reset.

- **In position**

The "In position signal" must only be used in conjunction with *FCB 09 Positioning* (page 134).

Signal from 0 to 1 → The axis is "In position" when it enters the range defined in -parameter 9885.3 *Window width for in position message* (page 136) relative to the specified target. If a travel command was aborted with an FCB changeover but the drive still arrives in the position window by chance, then **no** "In position" message will be generated.

Signal 1 to 1 → The axis **loses** "In position" when it is outside parameter 9885.3 - "*Window width for in position message* (page 136) + parameter 9885.4 *Hysteresis range* (page 136) relative to the specified target. This avoids bouncing of the bit.

The IN position message does not disappear when changing from *FCB 09 Positioning* (page 134) as long as you are in the position window + hysteresis. However, the IN position message is only set within *FCB09 Positioning* (page 134).

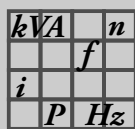

MX Parameter Description

Communication parameter description

FCB change

When changing to another FCB (e.g. FCB 13 Stop at application limits to activate the brake), the "In position" message at standstill will **not get lost**. When re-entering *FCB 09 Positioning* (page 134), the bit has remained unchanged.

The message is only removed when the position window + hysteresis range is exceeded relative to the last target. This applies to all FCBs. This means the message can **only** be generated within *FCB 09 Positioning* (page 134). The message is only removed when the position window + hysteresis range is left regardless of the current FCB.

- **Parameter set bit 0**

This bit is used for parameter set changeover (see also "Parameter set bit 1").

Bit 0 = 1 and bit 1 = 0 → Parameter set 1 active

Bit 0 = 0 and bit 1 = 1 → Parameter set 2 active

Bit 0 = 1 and bit 1 = 1 → Parameter set 3 active

MOVIAXIS® supports 3 physically connected motors with encoder feedback. An additional "XGK11A encoder card" option is required each for the second and third motor to connect the additional encoder feedback systems. The motor power cables must be distributed through a changeover switch (not included in the SEW scope of delivery) to the individual motors. The individual motors/parameter sets must first be entered in the startup routine.

- **Parameter set bit 1**

See "Parameter set bit 0"

- **Setpoints active**

This message is active in all setpoint processing FCBs when setpoints are being processed. These are *FCB 05 (page 122) – FCB 10 (page 142)*. The message is set to 0 in all stop FCBs and the default FCB. The message is still 0 during the brake release time.

- **Torque limit reached**

This message indicates when the torque limit is reached: *9580.1 System limit maximum torque (page 51) 9740.4 Application limit maximum torque (page 53)* or maximum torque of the respective FCB.

- **IEC control error**

This message is in preparation.

- **IEC output**

This message is in preparation.

- **Fault**

This message is issued when the MOVIAXIS® unit is in error state. It is not relevant for the fault bit whether the output stage is inhibited immediately or not.

- **Message displayed fault**

This signal is a subset of "Fault" and displays error responses that are configured to "Display fault". The drive continues to operate normally.

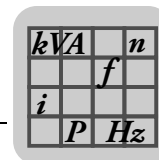

- **Fault without immediate output stage inhibit**

This signal is a subset of "Fault" and indicates that the drive can be decelerated using a ramp (motor does not coast to a halt or mechanical brake is not applied). This bit is also set when "Signal displayed error".

- **Error with immediate output stage inhibit**

This signal is a subset of "Fault" and indicates that the motor coasts to a halt or, if installed, the mechanical brake is applied.

- **FCBs**

The relevant message is set to 1 if the corresponding FCB is active.

- **Brake tested OK**

The FCB has successfully tested the brake and found it to be good according to the basic conditions set in FCB. Also see *FCB 21 brake test* (page 155).

- **Brake tested not OK**

The FCB brake test has assessed the brake as faulty. The higher-level controller now decides on the measures to be initiated. Also see *FCB 21 brake test* (page 155).

- **Output stage enable DI-00**

Displays the current status of the terminal DI00.

This parameter is usually set in the PDO Editor.

- **Motor commutated**

Shows whether the motor is commutated or not. In "Not commutated" status, the drive cannot be enabled.- This bit is only useful for synchronous motors with incremental encoders. For absolute encoders, the bit is always set to "TRUE".

- **24 V standby operation**

Mirrors the bit of the same name in the unit status (9702.1 Bit 8)

- **Process data not ready**

Mirrors the bit of the same name in the unit status (9702.1 Bit 13)

9559.2 – 16
Bit 1 – 15

Value range: See parameter "9559.1 Control word 0 bit 0" (page 92).

Programmable status word 0 layout bits 1 – 15.

Status word 1 – 3

Description of status words 1 – 3, see status word 0.

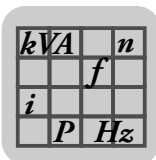

1.3.8 OUT process data

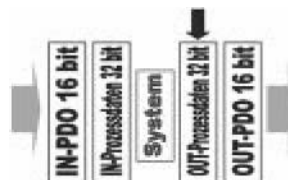

1242771211

Channel 0

9560.1 System
unit channel 0

Value range:

- 0=No unit
- 1=Actual speed
- 2=Position
- 3=Acceleration
- 4=Torque
- 5=Apparent current
- 6=Active current
- 7=Net torque
- 8=Virtual encoder position
- 9=System position

- No unit

The channel is not assigned.

- Actual speed

Shows the current actual speed in user-defined units.

- Position

Shows the current actual position in user-defined units.

- Acceleration

Shows the current actual acceleration in user-defined units.

- Torque

Displays the currently applied torque in user-defined units.

- Apparent current

Shows the currently flowing output current in A with 3 decimal places.

- Active current

Shows the currently flowing torque current in A with 3 decimal places.

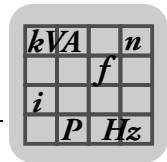

- System position
Position in increments.
Resolution: 65536/motor revolution.
- Modulo position
Displays the present modulo position.
- System position encoder 1/2/3
Shows the current position of the encoder 1/2/3 in increments.
Resolution: 65536/motor revolution.
This parameter is usually set in the PDO Editor.

9561.1 Actual value high word channel 0
Value range: -32768 – 0 – 32767, step 1.
OUT process data buffer (16 bit, high) 0 – 15.

9562.1 Actual value low word channel 0
Value range: -32768 – 0 – 32767, step 1.
OUT process data buffer (16 bit, low) 0 – 15.

Channel 1 – 15

9560.2 – 9560.16 System variable channel 1 – 15
Value range: See parameter "9560.1 System unit channel 0" (page 98).
System unit OUT process data buffer 1 – 15.

9561.2 – 9561.16 Actual value high word channel 1 – 15
Value range: -32768 – 0 – 32767, step 1.
OUT process data buffer (16 bit, high) 0 – 15.

9562.2 – 9562.16 Actual value low word channel 1 – 15
Value range: -32768 – 0 – 32767, step 1.
OUT process data buffer (16 bit, low) 0 – 15.

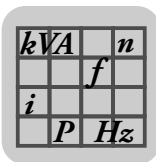

1.3.9 OUT buffer 0 – 7



1242773643

OUT buffer 0

Basic settings

9563.3 Data sink OUT buffer 0

Value range:

- 0=No sink
- 1=CAN2
- 2=CAN1
- 3=Communication option

The data sink is used to set the bus system on which the data is to be written.

This parameter is usually set in the PDO Editor.

9563.5 Data block start

The data block start describes beginning from which word data is to be written to the bus. Whether a value unequal to 0 may be entered depends on the bus system (e.g. the data block start for CAN is always 0).

This parameter is usually set in the PDO Editor.

9563.6 Data block length

Value range: 0 – 4 – 16, step 1.

The data block length also depends on the bus system, e.g. for CAN = maximum 4.

This parameter is usually set in the PDO Editor.

9563.16 Config error

Value range: 0 – 4294967295, step 1.

The config error indicates any error.

This parameter is usually set in the PDO Editor.

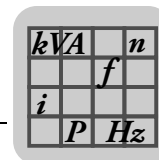

Specific CAN parameters

- 9563.4 Message ID** Value range: 0 – 1073741823, step 1.
 The message ID is a CAN-specific parameter. It numbers or prioritizes the messages.
 This parameter is usually set in the PDO Editor.
- 9563.1 Send PDO after sync** Value range:
 • 0=No
 • 1=Yes
 This parameter allows for cyclical sending of PDOs that will be sent connected to the sync. For this purpose, parameter *9563.22 Send PDO after n syncs* (page 101) needs to know after how many syncs a new PDO is to be sent.
- 9563.17 Blocking time** Unit: μs
 Value range: 0 – 100000000, step 1000.
 This parameter applies in conjunction with parameter *9563.23 Send PDO following change* (page 102); if the PDO changes permanently, the blocking time will still be maintained cyclically and the PDO will not be sent more often.
 This parameter is usually set in the PDO Editor.
- 9563.21 Endianness** Value range: See parameter *9514.20 Endianness IN buffer 0* (page 82).
 This parameter is used to set whether the first of the two bytes from the bus is interpreted as high or low byte.
 • **Big Endian**
 The first byte is interpreted as high byte.
 • **Little Endian**
 The first byte is interpreted as low byte. This is a CAN-specific parameter.
 This parameter is usually set in the PDO Editor.
- 9563.2 Send PDO cyclically** Unit: μs
 Value range: 0 – 65535000, step 1000.
 This parameter sets the cycle time if the PDO is to be sent cyclically when parameter *9563.23 Send PDO following change* (page 102) is set to "No".
 This parameter is usually set in the PDO Editor.
- 9563.22 Send PDO after n syncs** Value range: 0 – 255, step 1.
 See parameter *9563.1 Send PDO after sync* (page 101).
 This parameter is usually set in the PDO Editor.

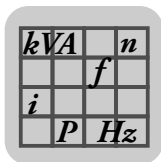

MX Parameter Description

Communication parameter description

9563.23 Send
PDO following
change

Value range:

- 0=No
- 1=Yes

The setting "Yes" means PDOs are only sent following a change, see also parameter 9563.17 *Blocking time* (page 101).

This parameter is usually set in the PDO Editor.

9563.19 Send
PDO following
change of IN buffer

Value range:

- 0=No RxPDO
- 1=from IN PDO1
- 2=from IN PDO1
- 3=from IN PDO2
- 4=from IN PDO3
- 5=from IN PDO4
- 6=from IN PDO5
- 7=from IN PDO6
- 8=from IN PDO7
- 9=from IN PDO8
- 10=from IN PDO9
- 11=from IN PDO10
- 12=from IN PDO11
- 13=from IN PDO12
- 14=from IN PDO13
- 15=from IN PDO14
- 16=from IN PDO15

This parameter allows for sending a PDO only if the IN PDO has changed. Parameter 9563.17 *Blocking time* (page 101) can be used to prevent that PDOs are sent permanently.

This parameter is usually set in the PDO Editor.

Specific communication option parameters

9563.18 PDO ID

Value range: 0 – 255, step 1.

This parameter only applies to the K-Net bus system and sets the PDO address.

This parameter is usually set in the PDO Editor.

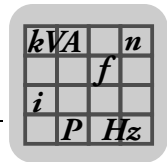

9563.24 Transmission cycle

Value range:

- 0=Bus cycle
- 1=Gateway cycle

In preparation.

This parameter is usually set in the PDO Editor.

Data sources

9770.1 Data source word 0

This parameter is usually set in the PDO Editor because of the many setting options.

9864.1 – 9864.16 Actual value word 0 – 15

Value range: 0 – 65535, step 1.

Actual data word 0 – 15 OUT buffer 0.

9770.2 – 9770.16 Data source word 1 – 15

Value range: See parameter *9770.1 Data source word 0* (page 103).

OUT buffer 1 – 7

Description see OUT buffer 0

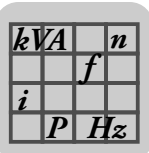

1.3.10 I/O basic unit

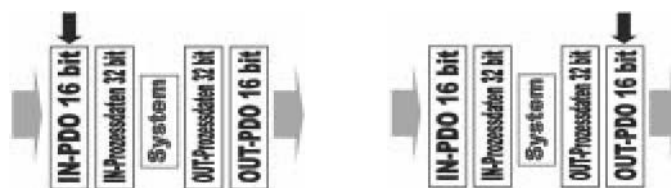

1242776075

9585.1 Source

Value range: This parameter is usually set in the PDO Editor because of the many setting options.

Source binary outputs basic unit.

8334.0 Actual value digital inputs

Actual value digital inputs.

8349.0 Actual value digital outputs

Actual value digital outputs.

1.3.11 I/O option 1



1242778507

9619.1 I/O PDO 1 slot

Value range:

- 0=Not connected
- 1=Option 1
- 2=Option 2
- 3=Option 3

I/O PDO 1 slot

9619.111 PDO source

Value range: This parameter is usually set in the PDO Editor because of the many setting options.

I/O PDO 1 PDO 1 source

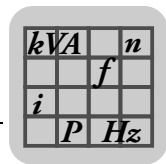

Analog inputs

<i>9619.21 AI0 input voltage</i>	Unit: mV IO PDO 1 AI0 input voltage.
<i>9619.31 AI1 input voltage</i>	Unit: mV I/O PDO 1 AI1 input voltage.
<i>9619.22 AI0 offset</i>	Unit: mV Value range: -10000 – 0 – 10000, step 1. I/O PDO 1 AI0 offset
<i>9619.32 AI1 offset</i>	Unit: mV Value range: -10000 – 0 – 10000, step 1. I/O PDO 1 AI1 offset
<i>9619.23 AI0 scaling numerator</i>	Value range: 1 – 2097151, step 1. I/O PDO 1 AI0 scaling numerator.
<i>9619.33 AI1 scaling numerator</i>	Value range: 1 – 2097151, step 1. I/O PDO 1 AI1 scaling numerator.
<i>9619.24 AI1 scaling denominator</i>	Value range: 1 – 2097151, step 1. I/O PDO 1 AI1 scaling denominator.
<i>9619.34 AI2 scaling denominator</i>	Value range: 1 – 2097151, step 1. I/O PDO 1 AI2 scaling denominator.
<i>9619.25 AI1 scaled value 32 bit</i>	I/O PDO 1 AI1 scaled value 32 bit.
<i>9619.35 AI2 scaled value 32 bit</i>	I/O PDO 1 AI2 scaled value 32 bit.
<i>9619.27 AI1 scaled value high word</i>	I/O PDO 1 AI1 scaled value high word.
<i>9619.37 AI2 scaled value high word</i>	I/O PDO 1 AI2 scaled value high word.
<i>9619.26 AI1 scaled value low word</i>	I/O PDO 1 AI1 scaled value low word.
<i>9619.36 AI2 scaled value low word</i>	I/O PDO 1 AI2 scaled value low word.

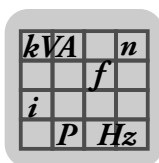

MX Parameter Description

Communication parameter description

Analog outputs

9619.122 AO1 high word source	Value range: See parameter 9770.1 <i>Data source word 0</i> (page 103). I/O PDO 1 AO1 high word source.
9619.132 AO2 high word source	Value range: See parameter 9770.1 <i>Data source word 0</i> (page 103). I/O PDO 1 AO2 high word source.
9619.121 AO1 low word source	Value range: See parameter 9770.1 <i>Data source word 0</i> (page 103). I/O PDO 1 AO1 low word source.
9619.131 AO2 low word source	Value range: See parameter 9770.1 <i>Data source word 0</i> (page 103). I/O PDO 1 AO2 low word source.
9619.123 AO1 value source 32 bit	I/O PDO 1 AO1 actual value 32 bit.
9619.133 AO2 value source 32 bit	I/O PDO 1 AO2 actual value 32 bit.
9619.124 AO1 scaling to V numerator	Value range: 1 – 2097151, step 1. I/O PDO 1 AO1 scaling numerator.
9619.134 AO2 scaling to V numerator	Value range: 1 – 2097151, step 1. I/O PDO 1 AO2 scaling numerator.
9619.125 AO1 scaling to V denominator	Value range: 1 – 2097151, step 1. I/O PDO 1 AO1 scaling denominator.
9619.135 AO2 scaling to V denominator	Value range: 1 – 2097151, step 1. I/O PDO 1 AO2 scaling denominator.
9619.126 AO1 offset	Unit: mV Value range: -10000 – 0 – 10000, step 1. I/O PDO 1 AO1 offset
9619.136 AO2 offset	Unit: mV Value range: -10000 – 0 – 10000, step 1. I/O PDO 1 AO2 offset.
9619.127 AO1 output voltage	Unit: mV I/O PDO 1 AO1 output voltage.

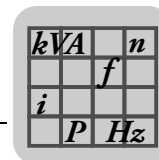

9619.137 AO2
output voltage Unit: mV
I/O PDO 1 AO2 output voltage.

1.3.12 I/O option 2



1242778507

9625.1 I/O PDO 2
slot Value range: See parameter "9585.1 Source I/O basic unit" (page 104).
I/O PDO 2 slot

9625.111 PDO
source Value range: This parameter is usually set in the PDO Editor because of the many
setting options.
I/O PDO 2 PDO 2 source

Analog inputs

9625.21 AI1 input
voltage Unit: mV
I/O PDO 2 AI1 input voltage.

9625.31 AI2 input
voltage Unit: mV
I/O PDO 2 AI2 input voltage.

9625.22 AI1 offset Unit: mV
Value range: -10000 – 0 – 10000, step 1.
I/O PDO 2 AI1 offset

9625.32 AI2 offset Unit: mV
Value range: -10000 – 0 – 10000, step 1.
I/O PDO 2 AI2 offset

9625.23 AI1
scaling numerator Value range: 1 – 2097151, step 1.
I/O PDO 2 AI1 scaling numerator.

9625.33 AI2
scaling numerator Value range: 1 – 2097151, step 1.
I/O PDO 2 AI2 scaling numerator.

9625.24 AI1 scal-
ing denominator Value range: 1 – 2097151, step 1.
I/O PDO 2 AI1 scaling denominator.

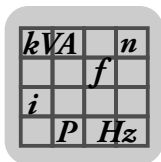

MX Parameter Description

Communication parameter description

9625.34 AI2 scaling denominator	Value range: 1 – 2097151, step 1. I/O PDO 2 AI2 scaling denominator.
9625.25 AI1 scaled value 32 bit	I/O PDO 2 AI1 scaled value 32 bit.
9625.35 AI2 scaled value 32 bit	I/O PDO 2 AI2 scaled value 32 bit.
9625.27 AI1 scaled value high word	I/O PDO 2 AI1 scaled value high word.
9625.37 AI2 scaled value high word	I/O PDO 2 AI2 scaled value high word.
9625.26 AI1 scaled value low word	I/O PDO 2 AI1 scaled value low word.
9625.36 AI2 scaled value low word	I/O PDO 2 AI2 scaled value low word.
<i>Analog outputs</i>	
9625.122 AO1 high word source	Value range: See parameter 9770.1 Data source word 0 (page 103). I/O PDO 2 AO1 high word source.
9625.132 AO2 high word source	Value range: See parameter 9770.1 Data source word 0 (page 103). I/O PDO 2 AO2 high word source.
9625.121 AO1 low word source	Value range: See parameter 9770.1 Data source word 0 (page 103). I/O PDO 2 AO1 low word source.
9625.131 AO2 low word source	Value range: See parameter 9770.1 Data source word 0 (page 103). I/O PDO 2 AO2 low word source.
9625.123 AO1 value source 32 bit	I/O PDO 2 AO1 actual value 32 bit.
9625.133 AO2 value source 32 bit	I/O PDO 2 AO2 actual value 32 bit.
9625.124 AO1 scaling to V numerator	Value range: 1 – 2097151, step 1. I/O PDO 2 AO1 scaling numerator.
9625.134 AO2 scaling to V numerator	Value range: 1 – 2097151, step 1. I/O PDO 2 AO2 scaling numerator.

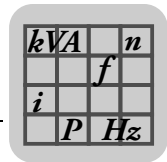

<i>9625.125 AO1 scaling to V denominator</i>	Value range: 1 – 2097151, step 1. I/O PDO 2 AO1 scaling denominator.
<i>9625.135 AO2 scaling to V denominator</i>	Value range: 1 – 2097151, step 1. I/O PDO 2 AO2 scaling denominator.
<i>9625.126 AO1 offset</i>	Unit: mV Value range: -10000 – 0 – 10000, step 1. I/O PDO 2 AO1 offset
<i>9625.136 AO2 offset</i>	Unit: mV Value range: -10000 – 0 – 10000, step 1. I/O PDO 2 AO2 offset.
<i>9625.127 AO1 output voltage</i>	Unit: mV I/O PDO 2 AO1 output voltage.
<i>9625.137 AO2 output voltage</i>	Unit: mV I/O PDO 2 AO2 output voltage.

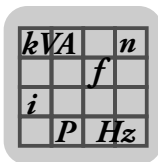

1.4 Encoder parameter description

The following encoders can be evaluated using the encoder evaluation function integrated in the MOVIAXIS[®] basic unit:

- HIPERFACE[®] encoder
- Sin/cos encoder
- TTL encoder
- Resolver (2 – 12 pole pairs)

With resolver, sin/cos and TTL encoders, MOVIAXIS[®] monitors the failure of track signals caused by faults or cable problems (amplitude monitoring).

If MOVIAXIS[®] detects an error, the output stage inhibit and brake are activated.

With the "Encoder calibration and adjustment" function, a fixed rotating field space vector is impressed in the motor. If the rotor aligns itself according to this space vector, the encoder angle is "0" with the SEW encoder setting.

If this is not the case, the encoder offset can be calibrated with MOVIAXIS[®] and/or

- Entered in encoder offset parameter,
- The encoder can be aligned accordingly (resolver),
- The encoder offset can be written to the encoder (Hiperface[®]).

1.4.1 Encoder input of basic unit

9818.34 / 9818.24 Value range: 0 – 2³² step 1

/ 9818.20 Encoder Encoder part number; encoder 1 / encoder 2 / encoder 3

part number/
encoder name

The part number of the selected encoder is displayed in parameter 9818.34.

MotionStudio generates the encoder name from this. Encoders that are not from SEW are assigned a part number smaller than 8 digits.

9733.1 / 9733.2 /
9733.3 Encoder
type

Value range:

- 0 = No encoder
- 1 = RS422
- 3 = Sin / cos XXXS
- 4 = Hiperface[®] XXXH
- 5 = Resolver RHXX

Type encoder 1 / encoder 2 / encoder 3.

With encoder 1 (encoder input X13 on the axis module), only settings 0 – 5 are possible.

The multi encoder card (MGK) can select all settings except for the Resolver (5) setting.

kVA	n
	f
i	
P	H_z

9719.1 / 9719.2 /
9719.3 Counting
direction

Value range:

- 0 = Up
- 1 = Down

Counting direction encoder 1 / encoder 2 / encoder 3.

The parameter depends on the installation position of the encoder and is independent of the setting of parameter 8537.0 *Direction of rotation reversal* (page 23). Do not confuse the two parameters. The counting direction of the encoder is reversed which means also the actual values of position, speed and acceleration for this encoder are reversed.

This parameter can be used to support encoders that are installed other than the standard installation. Changing the counting direction generally causes de-referencing of the drive.

The encoder system is reinitialized when this parameter is changed.

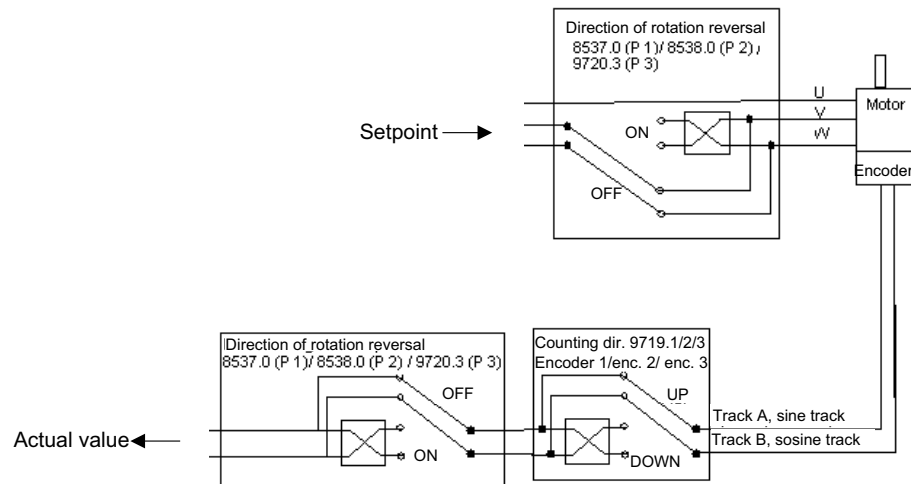

1242927115

• Setting the parameter

The following notes for setting the parameters apply provided that the parameter 8537.0 *Direction of rotation reversal* (page 23) is set to "OFF". If the parameter for changing the direction of rotation is set to "ON", the direction of rotation of the motor shaft is inverted.

• Setting for rotary motors

- If the encoder provides a positive increasing position when the motor shaft turns in CW (right) direction (SEW definition as viewed onto the motor shaft), then the counting direction must be set to "UP" (default setting).
- If the encoder provides a negative decreasing position when the motor shaft turns in CW (right) direction, then the counting direction must be set to "DOWN".

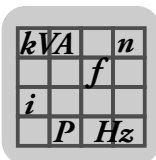

MX Parameter Description

Encoder parameter description

- **Setting for linear motors**

- If the encoder provides a positive increasing position when the motor moves in positive direction (SEW definition: first movement for commutation travel following motor alignment), the counting direction must be set to "UP" (default setting).
- If the encoder provides a negative increasing position when the motor moves in positive direction (SEW definition: first movement for commutation travel following motor alignment), the counting direction must be set to "DOWN" (default setting).

9749.11 / 9749.12 /
9749.13 Encoder
monitoring

Value range:

- 0 = OFF
- 1 = ON

Monitoring encoder 1/2/3.

- **SIN / COS signal:**

The C track is not monitored for MOVIAXIS®.

Monitoring responds when the amplitude falls below 10 % of the measuring range. Wire breakage monitoring is not completely possible when the motor is at standstill. The error criterion is not fulfilled if the undamaged track has a high positive or negative value. Monitoring will always trigger if both tracks are damaged.

- **TTL signal:**

The track signals are monitored by measuring the differential voltages of the two tracks A and B.

When the motor is at standstill, wire breakage monitoring is not possible when only one wire pair of a track is damaged.

- **Hiperface® signal:**

During operation, a positioning request is sent to the Hiperface® encoder every second. The position value in the response message is compared with a TTL track signal. If the position deviates by more than 20 increments, an error ("error 15") will be issued. The encoder status is queried after every position request (see section "Encoder status" (page 115)).

A check is still made to assess whether an encoder is physically present when the encoder setting "0 = OFF".

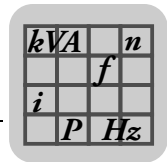

9593.1 / 9593.2 /
9593.3 Numerator
factor

Value range: 0 – 1024 – 2147483647, step 1.
Factor numerator encoder 1 encoder 2 / encoder 3.

Numerator / denominator factor

This factor determines the encoder resolution. Enter the value in parameter 9733.1 -Encoder type (page 110):

- Encoder (encoder type = 1, 3, 4)

$$\frac{\text{Factor numerator encoder 1}}{\text{Factor denominator encoder 1}} = \frac{\text{Encoder resolution}}{\text{Revolution}}$$

1243032843

Example: SinCos AS1H encoder
Factor numerator encoder 1 = 1024
Factor denominator encoder 1 = 1

- Resolver (encoder type = 5)

$$\frac{\text{Factor numerator encoder 1}}{\text{Factor denominator encoder 1}} = \frac{\text{Pole pair number resolver}}{1}$$

1243035275

Example: Resolver, number of pole pairs = 1
Factor numerator encoder 1 = 1
Factor denominator encoder 1 = 1

- Linear motor (encoder type = 1, 3, 4)

$$\frac{\text{Factor numerator encoder 1}}{\text{Factor denominator encoder 1}} = \frac{\text{Signal period [mm]}}{\text{Pole pair width [mm]}}$$

1243037707

Example: AL1H (Lincoder, signal period 5 mm), with SL2 motor (pole distance 32 mm)
Factor numerator encoder 1 = 32
Factor denominator encoder 1 = 5

9593.10 / 9593.11 /
9593.12 Denomi-
nator factor

Value range: 1 – 2147483647, step 1.
Factor denominator encoder 1 / encoder 2 / encoder 3.
See parameter 9593.1 Numerator factor (page 113).

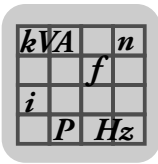

MX Parameter Description

Encoder parameter description

9828.2 / 9828.3
Numerator emulation
 Value range: 0 – 1024 – 2147483647, step 1.
 Numerator emulation encoder 2 / encoder 3.

9829.2 / 9829.3
Denominator emulation
 Value range: 1 – 2147483647, step 1.
 Denominator emulation encoder 2 / encoder 3.

1.4.2 Position mode settings

9998.1 / 9998.2 /
 9998.3 *Position mode*
 Value range:

- 0 = Without overflow counter
- 1 = With overflow counter

Position mode

The reset behavior of parameter 9998.1 *Position mode* in conjunction with absolute encoders depends on the following settings:

- If set to "**without overflow counter**", the unit will always be positioned in the absolute range of the encoder following a CPU reset and system restart, e.g. with Hiperface[®] 4096 motor revolutions. This means a position loss in the event of encoder overflow. If the position range of the absolute encoder is not exceeded, no reference travel is required when replacing MOVIAXIS[®] because no overflows can be stored in the MOVIAXIS[®]. Reference travel is only required when the motor is replaced. With this setting, the parameter 9999.11 *Relative position of reference point* (page 115) must be set.
- When set to "**With overflow counter**", the complete ± 32768 motor revolutions are utilized despite overflow. MOVIAXIS[®] stores absolute encoder overflows internally. This also functions when the axis is moved to overflow without electrical current. This is ensured by checking the travel range. Reference travel must always be performed when replacing MOVIAXIS[®] or the motor.

The maximum target position must not exceed the total from the current target position ± 16000 revolutions.

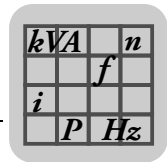

9999.11 / 9999.12 / 9999.13 *Relative position of the reference point*

Value range: 0 – 50000 – 100000, step 1.

Relative position of reference point encoder 1/2/3.

The parameter is required if parameter 9998.1 *Position mode* (page 114) is set to "without overflow counter".

With parameter *Relative position of reference point*, the position of the reference point (e.g. reference cam) should be specified in relation to the required total travel range in percent.

The valid travel range depends on the absolute encoder range and the relative position of the reference point.

Leaving the valid travel range is reported for MOVIAXIS® units supplied by 24 V.

- **Required travel range < 50 % absolute encoder range:**

You can use the default setting (50 %) if the required travel range is less than half the absolute range of the encoder.

- **Required travel range > 50 % absolute encoder range:**

If the reference point is located within the first quarter of the travel distance, then the value should be set to 25%. Never set the value to 0% or 100% even if the reference point is located at the start/end of the travel distance as this might result in travel range monitoring errors. In this case, the values should be set to 5% or 95%.

1.4.3 Actual values

9596.1 / 9596.2 / 9596.3 *Referenced (encoder status bit 7)*

Reference status encoder 1/2/3.

The encoder status bit 7 indicates whether an encoder is referenced or not. This value is read only and is set when reference travel is complete. The status bit is cleared when 24 V supply is off and no multi-turn encoder is used.

The status is also cleared in the event of write access to parameters that have an influence on the positions.

These are:

- Encoder type
- Direction of rotation of the motor
- Counting direction of the encoder
- Machine zero offset
- Position detection mode (encoder referencing only for multi-turn absolute encoder)
- Position offset (only if position detection mode 1 is active and the encoder is a multi-turn absolute encoder).
- Numerator factor (system unit) / denominator factor (system unit)
- Numerator factor (system unit) / denominator factor (system unit) for encoder emulation
- Numerator factor (user-defined unit) / denominator factor (user-defined unit)
- Modulo overflow / underflow value
- All SSI setting parameters and Endat setting parameters.

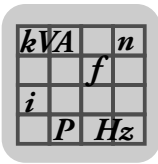

MX Parameter Description

Encoder parameter description

9595.1 / 9595.2 /
9595.3 *Connected
to drive no.*

Value range: 0 – 1 – 7, step 1.

Parameter set selection for encoder 1/2/3.

This parameter is used to assign a parameter set number to encoder 1/2/3. This means the user-defined unit for this encoder information is also defined.



INFORMATION

The parameters *9744.1/2/3 Actual position source* (page 117) and *9597.1/2/3 Actual speed source* (page 117) can only be switched to the encoder that was assigned to the parameter set here.

9782.1 / 9782.2 /
9782.3 *Encoder
identification*

Value range: 0 – 4294967295, step 1.

Encoder identification of encoder 1/2/3.

With Hiperface® encoders, the encoder identification is read from the electronic nameplate.

The number identifies the encoder type and is described in the Hiperface® documentation from SICK Stegmann.

9751.11 / 9751.12 /
9751.13 *Machine
zero offset*

Value range: -2147483648 – 0 – 2147483647, step 1.

Zero point correction encoder 1/2/3.

When using multi-turn encoders, another offset value (machine zero offset) has to be calculated and stored non-volatile following referencing. This offset allows for recovering all positions after a power failure. No reference travel is necessary in this case.

The controller sets this parameter by itself during referencing.

9704.1 *Actual
position*

Displays the actual position in user defined units for the position controller.

Is suited for output in the scope but is not consistent with the motor control parameters.

Corresponds to parameters *9704.2/3 or 4* according to which one was switched with parameter *9744.1 Source actual position* (page 117) for the position controller.

10444.1 / 10444.2
/ 10444.3 *Actual
position*

Displays actual position of encoder 1/2//3 in system units.

Is suited for output in the scope but is not consistent with the motor control parameters.

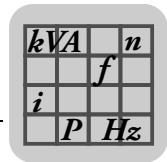

- 9704.2 / 9704.3 / 9704.4 Actual position
Display actual position of encoder 1/2/3 in user-defined units.
Is suited for output in the scope but is not consistent with the motor control parameters.
- 9839.2 / 9839.3 / 9839.4 Actual position modulo
Value range: -2147483648 – 0 – 2147483647, step 1.
Display of Modulo position encoder 1/2/3 in user-defined units.
The display is filtered in MotionStudio.
- 9744.1 / 9744.2 / 9744.3 Actual position source
Value range:
 - 0 = No encoder
 - 1 = Encoder 1
 - 2 = Encoder 2
 - 3 = Encoder 3
 Actual position source P1/P2/P3.
 The parameter is set in the parameter tree folder "Motor data".
 This parameter is used to select the encoder that provides the actual position information for the position controller of the motor control.
 The source of the actual position can also be switched to another source **during** controller enable.
 Only the encoder assigned to the parameter set number can be chosen as source.
 This is verified as long as the controller is enabled.
 See also parameter 9595.2 *Connected to drive no.* (page 116).
- 9597.1 / 9597.2 / 9597.3 Actual speed source
Value range:
 - 0 = No encoder
 - 1 = Encoder 1
 - 2 = Encoder 2
 - 3 = Encoder 3
 Source actual speed P1/P2/P3
 The parameter is set in the parameter tree folder "Motor data".
 This parameter is used to select the encoder that provides the information for the speed controller, current controller and commutation of the motor control.
 The source of the actual speed **cannot** be switched to another source during controller enable.

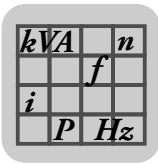

MX Parameter Description

Encoder parameter description

Only the encoder assigned to the parameter set number can be chosen as source.

This is verified when activating controller enable.

See also parameter 9595.2 *Connected to drive no.* (page 116).

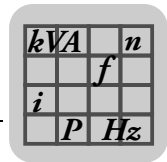

10068.1 Actual position

Displays the actual position of motor control for the position controller. Is suited for output in the scope and is consistent with the motor control parameters.

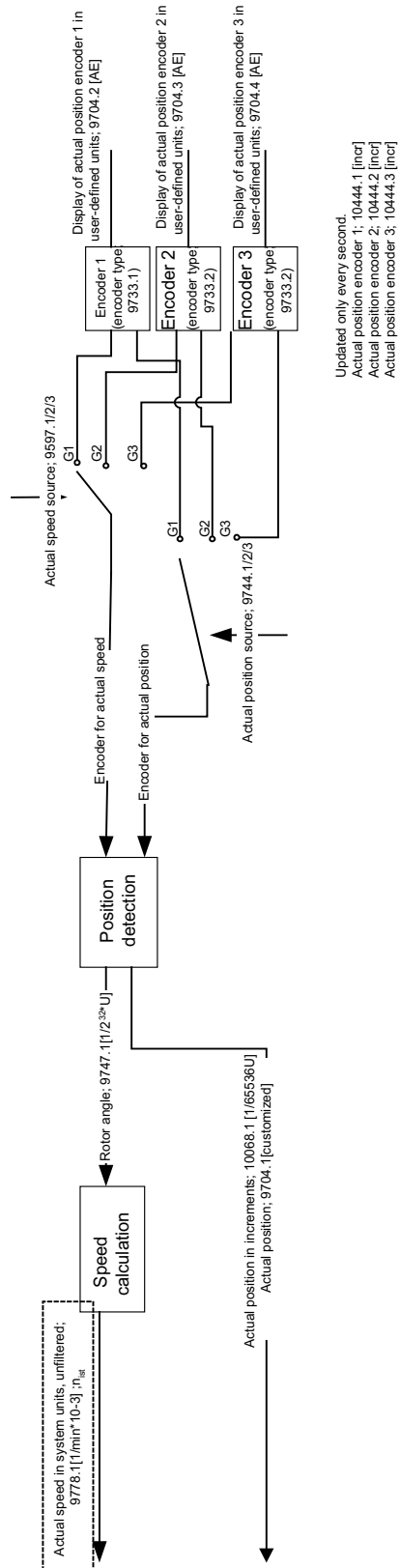

1243116939

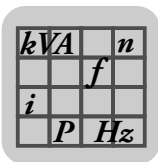

1.5 Parameter description for FCB parameter setting

1.5.1 FCB Function Control Block

The term "FCB concept" describes the modular firmware design of MOVIAXIS®. This feature ensures that a wide range of functions can be selected or deselected quickly and easily using control words without having to perform any programming.

All primary functions, i.e. functions that move or control the motors, are designed as individual FCBs that only have to be selected, for example, to perform positioning tasks.

The user can switch between FCBs at any time depending on the requested function.

1.5.2 Basic settings

9702.3 *Current FCB*

Currently active FCB number.

9702.6 *Current FCB instance*

Currently active FCB instance.

9804.1 *Select FCB with instance*

Low word definition (bits 0-15)

- 00 = FCB 00 Standard
- 01 = FCB 01 Output stage inhibited
- 05 = FCB 05 Speed control (page 122)
- 06 = FCB 06 Interpolated speed control (page 125)
- 07 = FCB 07 Torque control (page 131)
- 08 = FCB 08 Interpolated torque control (page 132)
- 09 = FCB 09 Position control instance 00 (page 134)
- 10 = FCB 10 Interpolated position control (page 142)
- 11 = Not assigned
- 12 = FCB 12 Reference travel (page 144)
- 13 = FCB 13 Stop
- 14 = FCB 14 Emergency stop
- 15 = FCB 15 Stop at system limits
- 16 = FCB 16 Electronic cam
- 17 = FCB 17 Electronic gear unit
- 18 = FCB 18 Encoder adjustment (page 145)
- 19 = FCB 19 Hold control
- 20 = FCB 20 Jog mode (page 153)
- 21 = FCB 21 Brake test function (page 155)
- 22 = FCB22 Multi-drive
- 25 = FCB25 Rotor position identification
- 26 = FCB26 Stop at user limits

High word definition (bits 16 – 31).

Instance 0 - 63 is selected in the high word.

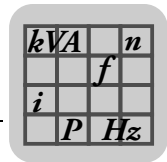

Direct selection of FCB number and FCB instance.

This parameter is one of several ways to select an FCB or instance. If several FCBs are selected at the same time, the FCB with highest priority will be activated.

The FCBs have the following priorities (starting with the highest priority):

- FCB 01 Output stage inhibited
- FCB 15 Stop at system limits
- FCB 14 Emergency stop
- FCB 13 Stop at application limits
- FCB 18 Encoder adjustment (page 145)
- FCB 25 Rotor position identification
- FCB 12 Reference travel (page 144)
- FCB 11 Limit switch operation
- FCB 20 Jog mode (page 153)
- FCB 19 Hold control
- FCB 21 Brake test function (page 155)
- FCB 22 Multi-drive
- FCB 17 Electronic gear unit
- FCB 16 Electronic cam
- FCB 10 Interpolated position control (page 142)
- FCB 09 Position control (page 134)
- FCB 06 Interpolated speed control (page 125)
- FCB 05 Speed control (page 122)
- FCB 08 Interpolated torque control (page 132)
- FCB 07 Torque control (page 131)
- FCB 26 Stop at user limits
- FCB 00 Standard (-> FCB 13 Stop at application limits)

If two instances are selected at the same time, the higher instance will be activated.

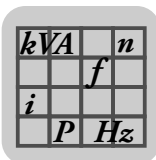

MX Parameter Description

Parameter description for FCB parameter setting

The following FCBs can be assigned to an instance:

- FCB 09 Positioning (page 134)
- FCB 05 Speed control
- FCB 07 Torque control

This parameter is reset to *FCB 00 Standard* at a CPU reset or system restart, which is equivalent with *FCB 13 Stop at application limits*. At warm start, the set parameter is maintained.

9982.11 Stop FCB initialization

Value range: 0 – 3

This parameter influences the jerk limitation for a transition to one of the *stop FCBs 13 / 14 / 15 / 26*.

- Acceleration = 0

When switching over to a stop FCB from a speed higher than zero, the jerk limitation is set up anew, i.e. the current acceleration or deceleration becomes zero. Depending on the extent of the set jerk limit, the deceleration is set anew. This behavior results in a longer braking distance and can only be set for compatibility reasons. During an initial startup, select the setting "current acceleration".

- Current acceleration = 3

When switching over to a stop FCB from a speed higher than zero, the jerk limitation is not set up anew, i.e. the current deceleration is forwarded to the selected stop FCB. Deceleration ramps are not interrupted and braking distances are not extended.

This setting must be selected for every initial startup.

1.5.3 FCB 05 Speed control

MOVIAXIS® can be run as a speed-controlled axis.

The user can specify limit values for acceleration, deceleration and jerk as the basic conditions for speed control. The actual speed setpoint for the drive controller is generated in the controller cycle by a ramp generator integrated in MOVIAXIS® using the specified limit values.

You can configure several data sets (instances - and therefore "speed controllers" with different settings) for the "Speed control" function. You can switch between the instances using process data or parameter access.

In this way, for example, a process, in which speed controllers with different settings are used, is simple to implement using the instance switchover function.

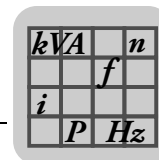

Setpoints

9598.1 / 10440.1
Velocity setpoint source

Value range:

- 0 = Local setpoint
- 1 = Process data buffer channel 0
- 2 = Process data buffer channel 1
- 3 = Process data buffer channel 2
- 4 = Process data buffer channel 3
- 5 = Process data buffer channel 4
- 6 = Process data buffer channel 5
- 7 = Process data buffer channel 6
- 8 = Process data buffer channel 7
- 9 = Process data buffer channel 8
- 10 = Process data buffer channel 9
- 11 = Process data buffer channel 10
- 12 = Process data buffer channel 11
- 13 = Process data buffer channel 12
- 14 = Process data buffer channel 13
- 15 = Process data buffer channel 14
- 16 = Process data buffer channel 15

This parameter sets the source for the setpoint speed of FCB speed control.

If the parameter is set to "Local setpoint", the setpoint source will be parameter **9598.2 Local velocity setpoint** (page 123).

9598.2 / 10440.2
Local velocity setpoint

Unit: 10⁻³/min.

Value range: -10000000 – 0 – 10000000, step 1.

If the parameter **9598.1 Velocity setpoint source** (page 123) is set to "Local setpoint", this parameter will be the setpoint speed for *FCB 05 Speed control* (page 122).

Limit values

9598.3 / 10440.3
Torque limit source

Value range: See parameter **9598.1 Setpoint source velocity** (page 123).

This parameter sets the source for the torque limit of *FCB speed control*.

If the parameter is set to "Local setpoint", the torque limit will be parameter **9598.4 Local torque limit** (page 123).

9598.4 / 10440.4
Local setpoint torque limit

Unit: %.

Resolution: 10⁻³.

Value range: 0 – 10000 – 1000000, step 1.

If parameter **9598.3 Torque limit source** (page 123) is set to "local setpoint", this parameter will be the torque limit for *FCB 05 Speed control* (page 122).

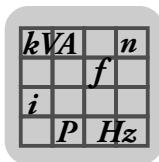

MX Parameter Description

Parameter description for FCB parameter setting

<p>9598.5 / 10440.5 <i>Acceleration source</i></p>	<p>Value range: See parameter 9598.1 <i>Setpoint source velocity</i> (page 123). This parameter sets the source for the acceleration of <i>FCB speed control</i>. If the parameter is set to "Local setpoint", the acceleration ramp will be parameter 9598.6 <i>Acceleration local</i> (page 124).</p>
<p>9598.6 / 10440.6 <i>Local acceleration setpoint</i></p>	<p>Unit: $10^{-2}/\text{min}\times\text{s}$. Value range: 0 – 300000 – 2147483647, step 1. If parameter 9598.5 <i>Acceleration source</i> (page 124) is set to "local setpoint", this parameter will be the acceleration ramp for <i>FCB 05 Speed control</i> (page 122).</p>
<p>9598.7 / 10440.7 <i>Deceleration source</i></p>	<p>Value range: See parameter 9598.1 <i>Setpoint source velocity</i> (page 123). This parameter sets the source for the deceleration of <i>FCB speed control</i>. If the parameter is set to "Local setpoint", the deceleration ramp will be parameter 9598.8 <i>Deceleration local</i> (page 124).</p>
<p>9598.8 / 10440.8 <i>Local deceleration setpoint</i></p>	<p>Unit: $10^{-2}/\text{min}\times\text{s}$. Value range: 0 – 300000 – 2147483647, step 1. If parameter 9598.7 <i>Deceleration source</i> (page 124) is set to "local setpoint", this parameter will be the deceleration ramp for <i>FCB 05 Speed control</i> (page 122).</p>
<p>9598.9 / 10440.9 <i>Jerk source</i></p>	<p>Value range: See parameter 9598.1 <i>Setpoint source velocity</i> (page 123). This parameter sets the source for the maximum jerk of <i>FCB speed control</i>. If the parameter is set to "local setpoint", the maximum jerk will be parameter 9598.10 <i>Local jerk</i> (page 124).</p>
<p>9598.10 / 10440.10 <i>Local jerk setpoint</i></p>	<p>Unit: $1/(\text{min}\times\text{s}^2)$. Value range: 0 – 2147483647, Step 1. If parameter 9598.9 <i>Jerk source</i> (page 124) is set to "local setpoint", this parameter will be the maximum jerk for <i>FCB 05 Speed control</i> (page 122).</p>
<p><i>Actual values</i> 9703.1 / 10120.1 <i>Velocity</i></p>	<p>Unit: $10^{-3}/\text{min}$ Current actual velocity (in user-defined units, filtered for display).</p>

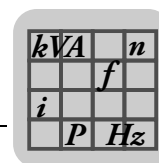

1.5.4 FCB 06 Interpolated speed control

FCB 06 interpolated speed control is used for cyclic preselected speed setpoints of higher-level controllers. The higher-level controller is responsible for the following limits:

- Jerk,
- Acceleration,
- Speed.

Only the speed and torque system limits take effect in MOVIAXIS®.

Prerequisite is a synchronized bus system. This means that incoming process data has a fixed time reference for the control system of the axis.

The new process data is sent within a fixed cycle time. This time must be a multiple of the cycle time of the speed control loop (parameter *9821.1 Scanning frequency n/X-control* (page 32); 250 µs, 500 µs or 1 ms).

MOVIAXIS® now has the task of forwarding the incoming speed setpoints with a rough time reference to the speed controller that operates with the shortest time reference. Intermediate values must be interpolated for this purpose. The setpoint flow is delayed by one communication cycle to carry out this interpolation.

The incoming position over two process data is interpreted in user-defined units.

General parameters

9963.1 Setpoint cycle control

Unit: µs.

Value range: 500 – 20000, step 500.

The setpoint cycle of the controller indicates the time intervals used by the higher-level controller to send speed setpoints. The time intervals must be a multiple of the cycle time of the speed control loop (parameter *9821.1 Scanning frequency n/X control* (page 32)).

Setpoints

9965.1 Speed setpoint source

This parameter sets the source for the speed setpoint of *FCB 06 Interpolated speed-control* (page 125).

If the parameter is set to "local setpoint", the source will be parameter *9965.2 Local speed setpoint* (page 125).

9965.2 Local speed setpoint

Unit: 10⁻³/min

Value range: -10000000 – 0 – 10000000, step 1.

If parameter *9965.1 Speed setpoint source* (page 125) is set to "local setpoint", this parameter will be the speed setpoint for *FCB 06 Interpolated speed control* (page 125).

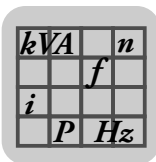

MX Parameter Description

Parameter description for FCB parameter setting

Limit values

9965.5 Torque limit mode

Value range:

- 0 = Single channel
- 1 = Two channels
- 2 = Four channels

The following modes can be set for limiting the torque:

- **0 = Single channel**

A limit value for all quadrants of the N-M diagram (parameter 9965.6 Torque limit Q1 absolute source (page 127)).

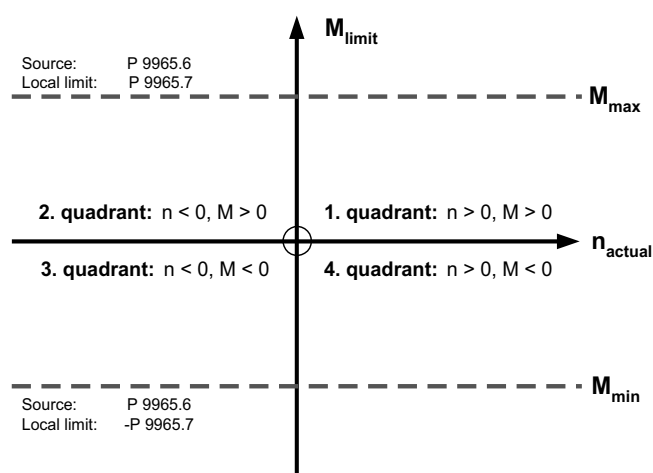

1243119883

- **1 = Two channels**

One value each for regenerative and motive range (parameter 9965.6 Torque limit Q1 abs. source (page 127) and parameter 9965.8 Torque limit Q2 abs. source (page 127)).

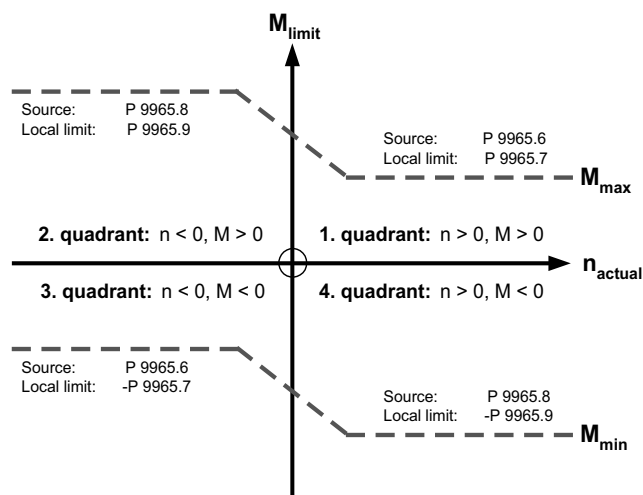

1243122315

• **2 = Four channels**

Every quadrant, whether regenerative, motor, positive or negative direction of rotation receives its own limit value.

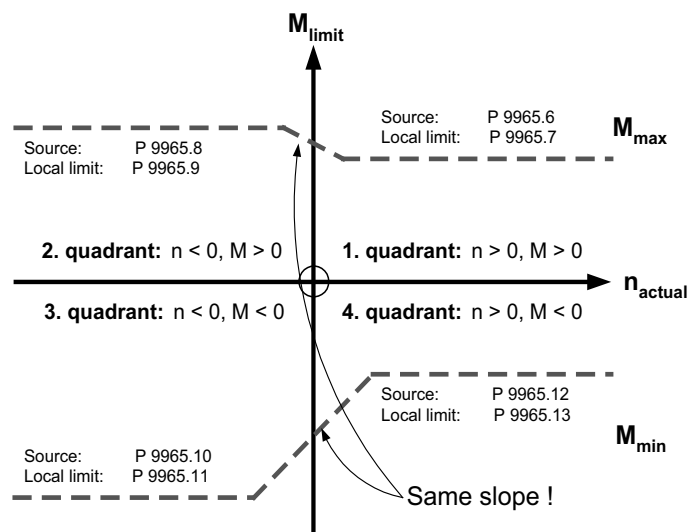

1243274123

9965.6 Abs.
source torque limit
Q1

Value range: see parameter 9598.1 Velocity setpoint source (page 123) FCB Speed control.

This parameter sets the source for the torque limit of the first quadrant (positive direction of rotation, motor mode) of FCB 06 Interpolated speed control (page 125).

If the parameter is set to "local setpoint", the source will be parameter 9965.7 Torque limit Q1 abs. local (page 127).

9965.7 Abs. local
torque limit Q1

Unit: %

Resolution: 10^{-3} .

Value range: 0 – 10000 – 1000000, step 1.

If the parameter 9965.6 Torque limit Q1 abs. source (page 127) is set to "Local setpoint", this parameter will be the torque limit for FCB 06 Interpolated speed control (page 125) in the relevant quadrant.

9965.8 Abs.
source torque limit
Q2

Value range: see parameter 9598.1 Velocity setpoint source (page 123) FCB Speed control.

This parameter sets the source for the torque limit of the second quadrant (negative direction of rotation, motor mode) of FCB 06 Interpolated speed control (page 125).

If the parameter is set to "local setpoint", the source will be parameter 9965.9 Torque limit Q2 abs. local (page 128).

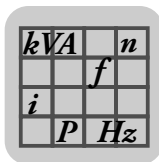

MX Parameter Description

Parameter description for FCB parameter setting

- 9965.9 Abs. local torque limit Q2**
- Unit: %
Resolution: 10^{-3} .
Value range: 0 – 10000 – 1000000, step 1.
If the parameter *9965.8 Torque limit Q2 abs. source* (page 127) is set to "Local setpoint", this parameter will be the torque limit for *FCB 06 Interpolated speed control* (page 125) in the relevant quadrant.
- 9965.10 Abs. source torque limit Q3**
- Value range: see parameter *9598.1 Velocity setpoint source* (page 123) *FCB Speed control*.
This parameter sets the source for the torque limit of the third quadrant (negative direction of rotation, regenerative mode) of *FCB 06 Interpolated speed control* (page 125).
If the parameter is set to "local setpoint", the source will be parameter *9965.11 Torque limit Q3 abs. local* (page 128).
- 9965.11 Abs. local torque limit Q3**
- Unit: %
Resolution: 10^{-3} .
Value range: 0 – 10000 – 1000000, step 1.
If the parameter *9965.10 Torque limit Q3 abs. source* (page 128) is set to "Local setpoint", this parameter will be the torque limit for *FCB 06 Interpolated speed control* (page 125) in the relevant quadrant.
- 9965.12 Abs. source torque limit Q4**
- Value range: see parameter *9598.1 Velocity setpoint source* (page 123) *FCB Speed control*.
This parameter sets the source for the torque limit of the fourth quadrant (positive direction of rotation, regenerative) of *FCB 06 Interpolated speed control* (page 125).
If the parameter is set to "local setpoint", the source will be parameter *9965.13 Torque limit Q4 abs. local* (page 128).
- 9965.13 Abs. local torque limit Q4**
- Unit: %
Resolution: 10^{-3} .
Value range: 0 – 10000 – 1000000, step 1.
If the parameter *9965.12 Torque limit Q4 abs. source* (page 128) is set to "Local setpoint", this parameter will be the torque limit for *FCB 06 Interpolated speed control* (page 125) in the relevant quadrant.

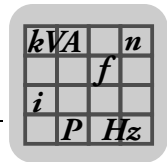

9965.16 Positive transition mode

- 0 = Center
- 1 = Motor mode
- 2 = Regenerative mode

The transition cannot take place suddenly between quadrants 1 and 2, or 3 and 4. For this reason, a linear transition is used with the slope of the P-component of the speed controller, see formula on the following page.

The transition will usually take place between quadrants 1 and 2, or 3 and 4 with speed 0. The effective limit torque for speed 0 is the average of the set limit torques of the adjacent quadrants (central transition mode and transition speed 0).

It may be required not to place the transition in the center with speed zero. In this case, the speeds can be set using parameters for which the limit torques merge. The parameter *9965.14 Transition speed positive (page 130)* defines the transition speed for the positive torque limit, which means between quadrants 1 and 2. Parameter *9965.15 Transition speed negative (page 131)* is used to set the transition speed for the negative torque limit between quadrants 3 and 4.

The specified transition speed can refer to the center of the transition area or to the motor or generative transition point of the transition area. The parameter *9965.16 Positive transition mode* determines the mode for the transition of the positive torque limit between quadrants 1 and 2. *9965.17 Negative transition mode (page 130)* refers to the transition between quadrants 3 and 4.

You can leave one of the two transition points at a specified speed by changing the amount of the torque limits and the resulting change of width of the transition area.

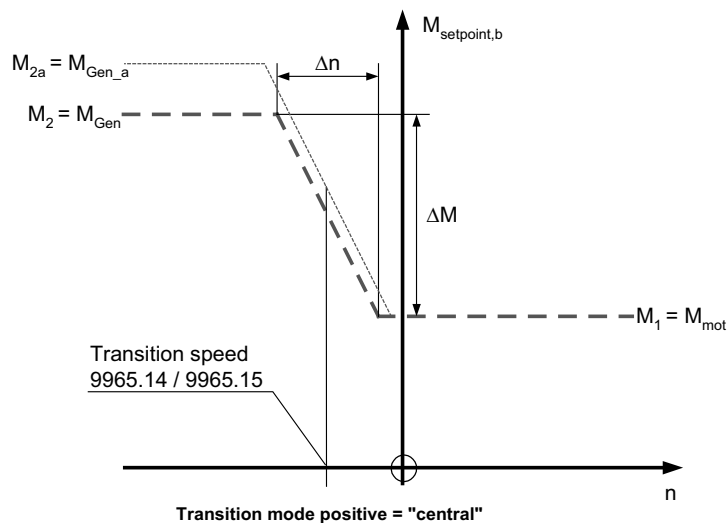

1243278347

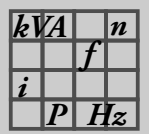

MX Parameter Description

Parameter description for FCB parameter setting

When increasing from M2 to M2a, the transition line moves up (Δn becomes larger), while the slope remains the same.

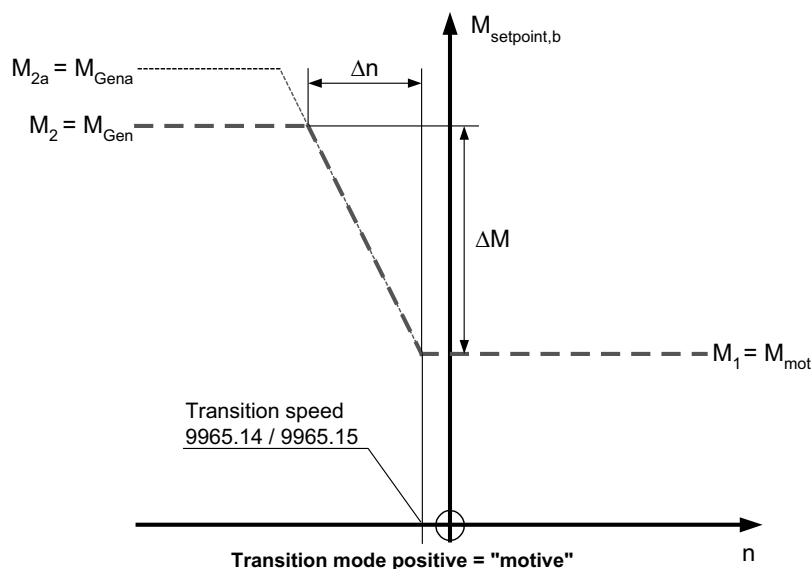

1243280779

When increasing from M2 to M2a, only the transition curve is extended (Δn also becomes larger) while the slope remains the same.

Calculating Δn :

$$\Delta n = \frac{(M_1 - M_2) \times Z \times M_{\text{motor_nominal}}}{N \times 200 \times \pi \times J_{\text{total}} \times P_{\text{inverter}}}$$

1243308811

M_1 = Parameter 9965.6 Torque limit Q1 abs. source (page 127) or parameter 9965.12 Torque limit Q4 abs. source (page 128) taking the decimal places into account.

M_2 = Parameter 9965.8 Torque limit Q2 abs. source (page 127) or parameter 9965.10 Torque limit Q3 abs. source (page 128) taking the decimal places into account.

Z = Parameter 9556.1 Torque numerator (page 57) (conversion of user-defined units to nominal motor torque)

$M_{\text{Motor_nominal}}$ = Parameter 9610.1 Nominal motor torque (page 37)

N = Parameter 9557.1 Torque denominator (page 58) (conversion of user-defined units to nominal motor torque)

J_{total} = Parameter 9817.1 Total moment of inertia (page 35)

P_{gain} = Parameter 9797.1 P-gain speed controller (page 32)

9965.14 Positive transition speed

Unit: $10^{-3}/\text{min}$

Value range: -10000000 – 0 – 10000000, step 1.

Positive transition speed (quadrants 1 and 2).

9965.17 Negative transition mode

Value range: See parameter 9965.16 Positive transition mode (page 129).

Negative transition mode (quadrants 3 and 4).

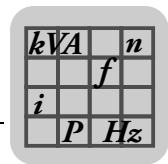

9965.15 Negative transition speed Unit: 10⁻³/min
Value range: -10000000 – 0 – 10000000, step 1.
Negative transition speed (quadrants 3 and 4).

Actual values

9703.1 Velocity Unit: 10⁻³/min
Current actual velocity; in user-defined units, filtered for display.

1.5.5 FCB 07 Torque control

MOVIAXIS® can be run as a torque-controlled axis.

The user can specify limit values for speed, acceleration and jerk as the basic conditions for torque control. The actual torque setpoint for the drive controller is generated in the controller cycle by a ramp generator integrated in MOVIAXIS® using the specified limit values.

The maximum speed can be limited during torque control. The speed limit can be changed dynamically using process data.

Setpoints

9599.1 / 10441.1 Torque setpoint source Value range: see parameter *9598.1 Velocity setpoint source* (page 123) *FCB Speed control*.
This parameter sets the source for the setpoint torque of FCB torque control.
If the parameter is set to "local setpoint", the source will be parameter *9599.2 Local torque setpoint* (page 131).

9599.2 / 10441.2 Local torque setpoint Unit: %
Resolution: 10⁻³.
Value range: -1000000 – 0 – 1000000, step 1.
If parameter *9599.1 Torque setpoint source* (page 131) is set to "local setpoint", this parameter will be the torque setpoint for *FCB 07 Torque control* (page 131).

Limit values

9599.3 / 10441.3 Source velocity limit Value range: see parameter *9598.1 Velocity setpoint source* (page 123) *FCB Speed control*.
This parameter sets the source for the velocity limit of *FCB 07 Torque control* (page 131).
If the parameter is set to "local setpoint", the torque limit will be parameter *9599.4 Local velocity limit* (page 132).

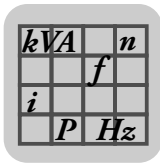

MX Parameter Description

Parameter description for FCB parameter setting

<p>9599.4 / 10441.4 <i>Local velocity limit</i></p>	<p>Unit: 10⁻³/min. Value range: 0 – <u>1000000</u>, Step 1. If parameter 9599.3 <i>Velocity limit source</i> (page 131) is set to "local setpoint", this parameter will be the velocity limit for <i>FCB 07 Torque control</i> (page 131).</p>
<p>9599.5 / 10441.5 <i>Jerk source</i></p>	<p>Value range: see parameter 9598.1 <i>Velocity setpoint source</i> (page 123) <i>FCB Speed control</i>. This parameter sets the source for the maximum jerk of the <i>FCB 07 Torque control</i> (page 131). If the parameter is set to "local setpoint", the maximum jerk will be parameter 9599.6 <i>Local jerk</i> (page 132).</p>
<p>9599.6 / 10441.6 <i>Local jerk</i></p>	<p>Unit: 1/(min×s²). Value range: 0 – 2147483647, step 1. If parameter 9599.5 <i>Jerk source</i> (page 132) is set to "local setpoint", this parameter will be the maximum jerk for <i>FCB 07 Torque control</i> (page 131).</p>
<p><i>Actual values</i></p>	
<p>9985.1 <i>User-defined unit torque</i></p>	<p>Unit: % Resolution: 10⁻³. Value range: -2147483648 – 2147483647, step 1. Current torque; in user-defined units, filtered for display.</p>

1.5.6 FCB 08 Interpolated torque control

For applications with a higher-level (motion control) controller, this controller usually calculates a track profile (x, y, z) for several drive axes. The axis is then assigned one setpoint (position, speed, torque) that it has to follow. MOVIAXIS[®] only limits the setpoints using the unit's internal system limits. The application limits for speed, acceleration and jerk must be taken from the track curve and are then controlled by the controller.

The cycle in which the controller sends the setpoints to the axes does not usually correspond with the setpoint processing cycle of MOVIAXIS[®] (500 μs). If MOVIAXIS[®] were to "see" the same controller setpoint for several cycles, a step-shaped actual torque value would result. To prevent this from happening, the axis can calculate intermediate values (interpolate) if it knows the controller cycle – interpolated speed control. MOVIAXIS[®] can be set to different cycles of higher-level controllers.

The FCB 08 interpolated torque control is used for cyclic preselected speed setpoints of higher-level controllers. The higher-level controller is responsible for the following limits:

- Jerk,
- Acceleration,
- Speed.

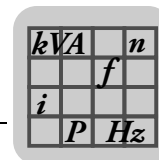

Only the speed and torque system limits take effect in MOVIAXIS®. Prerequisite is a synchronized bus system. This means that incoming process data has a fixed time reference for the control system of the axis.

The new process data is sent within a fixed cycle time. This time must be a multiple of the cycle time of the speed control loop (parameter *9821.1 Scanning frequency n/X-control* (page 32); 250 µs, 500 µs or 1 ms).

MOVIAXIS® now has the task of forwarding the incoming torque setpoints with a rough time reference to the speed controller that operates with the shortest time reference. Intermediate values must be interpolated for this purpose. The setpoint flow is delayed by one communication cycle to carry out this interpolation.

The incoming position over two process data is interpreted in user-defined units.

General parameters

9963.1 Setpoint cycle control

Unit: µs.

Value range: 500 – 20000, step 500.

The setpoint cycle of the controller indicates the time intervals used by the higher-level controller to send torque setpoints. The time intervals must be a multiple of the cycle time of the speed control loop (parameter *9821.1 Scanning frequency n/X control*" (page 32)).

Setpoints

9964.1 Torque setpoint source

Value range: see parameter *9598.1 Velocity setpoint source* (page 123) *FCB Speed control*.

This parameter sets the source for the torque setpoint of *FCB 08 interpolated torque control* (page 132).

If the parameter is set to "local setpoint", the source will be parameter *9964.2 Local torque setpoint* (page 133).

9964.2 Local torque setpoint

Unit: %

Resolution: 10⁻³.

Value range: -1000000 – 0 – 1000000, step 1.

If parameter *9964.1 Speed torque source* (page 133) is set to "local setpoint", this parameter will be the speed setpoint for *FCB 06 Interpolated speed control* (page 125).

9964.4 Velocity limit source

Unit:

Resolution:

Value range:

9964.3 Local velocity limit

Unit: rpm

Resolution:

Value range:

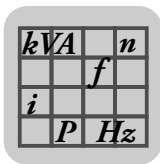

MX Parameter Description

Parameter description for FCB parameter setting

Actual values

9985.1 User-defined unit torque Unit: %
 Resolution: 10^{-3} .
 Value range: -2147483648 – 0 – 2147483647, step 1.
 Current torque; in user-defined units, filtered for display.

1.5.7 FCB 09 Positioning

MOVIAXIS® has a number of positioning mode types. These types are described briefly in the following section. FCB "Positioning" can be instanced to a maximum of 64 times.

Absolute positioning

The position setpoint in user-defined units is interpreted as an absolute target and is converted and executed in system units.

The travel range in system units is $\pm (2^{31} - 2)$. If this travel range is exceeded after the conversion, the FCB issues an error.

Relative positioning

The position setpoint in user units is interpreted as the offset for the last setpoint that was transferred. After it has been converted into system units, it is added to the last setpoint.

If the time calculated in system units is outside the travel range of $\pm (2^{32} - 2)$, the FCB issues an error.

Modulo in positive direction with absolute position specification

The position setpoint in user-defined units is interpreted as the absolute position. It must be within the modulo range of the active drive:

Lower limit = "Modulo underflow"

Upper limit = "Modulo overflow"

If the position setpoint is outside this range, an error is issued. The drive always turns in a positive direction to reach the specified position.

Modulo in positive direction with relative position specification

The position setpoint in user units is interpreted as the offset to the last setpoint that was transferred. After it has been converted into system units, it is added to the last setpoint.

The position setpoint must be **positive**, otherwise an error is issued.

The drive always turns in a positive direction to reach the new position.

Modulo in negative direction with absolute position specification

The position setpoint in user-defined units is interpreted as the absolute position. It must be within the modulo range of the active drive:

Lower limit = "Modulo underflow"

Upper limit = "Modulo overflow"

If the position setpoint is outside this range, an error is issued. The drive always turns in a negative direction to reach the new position.

Modulo in negative direction with relative position specification

The position setpoint in user units is interpreted as the offset to the last setpoint that was transferred. After it has been converted into system units, it is added to the last setpoint.

The position setpoint must be **negative**, otherwise an error is issued.

The drive always turns in a negative direction to reach the new position.

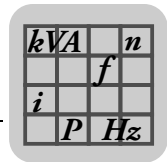

Modulo with shortest distance with absolute position specification

The position setpoint in user-defined units is interpreted as the absolute position. It must be within the modulo range of the active drive:

Lower limit = "Modulo underflow"

Upper limit = "Modulo overflow"

If the position setpoint is outside this range, an error is issued.

The direction of the drive is determined using the last setpoint position (= current actual position after activation without an "In position" message) and the current setpoint position. This value is used to determine the shortest possible route and, therefore, the direction of rotation for positioning.

Modulo with relative position specification

The position setpoint in user units is interpreted as the offset to the last setpoint that was transferred. After it has been converted into system units, it is added to the last setpoint.

The sign of the position setpoint determines the direction of rotation of the drive.

9885.1 Use control bit "feed enable"

Value range:

- 0 = No
- 1 = Yes

This parameter specifies whether "Feed enable" is to be used in the control word or not.

If this parameter is set to "Yes", a "Feed enable" bit must also be set in the layout of the control word. If the control word does not contain such a bit, this parameter must be set to "No", else the drive will not start.

The "Feed enable" bit in the control word must be set during the entire positioning distance. Deactivating feed enable results in standstill of the drive with the maximum deceleration of *FCB 09 positioning* (page 134) (*parameters 9886.8 – 9949.8*, depending on the instance). *FCB 09* (page 134) is not exited. Positioning is continued by setting feed enable again.

9885.2 Control bit "Accept position"

Value range:

- 0 = No
- 1 = Yes

This parameter specifies whether the "Accept position" bit is to be used in the control word or not.

If this parameter is set to "Yes", an "Accept position" bit must also be set in the layout of the control word. If the control word does not contain such a bit, this parameter must be set to "No", else the drive will not start.

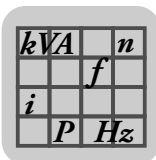

MX Parameter Description

Parameter description for FCB parameter setting

The "Accept position" bit must receive a positive edge for each new positioning procedure to accept the position. This is especially advantageous in the relative operating modes (index operating mode 9886.1 – 9949.1) → Relative cycles of the same position widths. The number of positive edges is saved and immediately processed. Example: Setpoint position relative to 100 revolutions. 220 revolutions are traveled by two quick successive changeovers (toggle) of the "Accept position" bit in the control word.

9885.3 In Position window

The window width for the "In position" message indicates when MOVIAXIS® sends back the information that the target position is reached to the PLC in the status word. The position window can now also be provided with a hysteresis using the parameter 9885.4 *In position message hysteresis range* (page 136). The actual position can dip into the hysteresis range when it has entered the position window without losing the "In position". This prevents the bit from "bouncing".

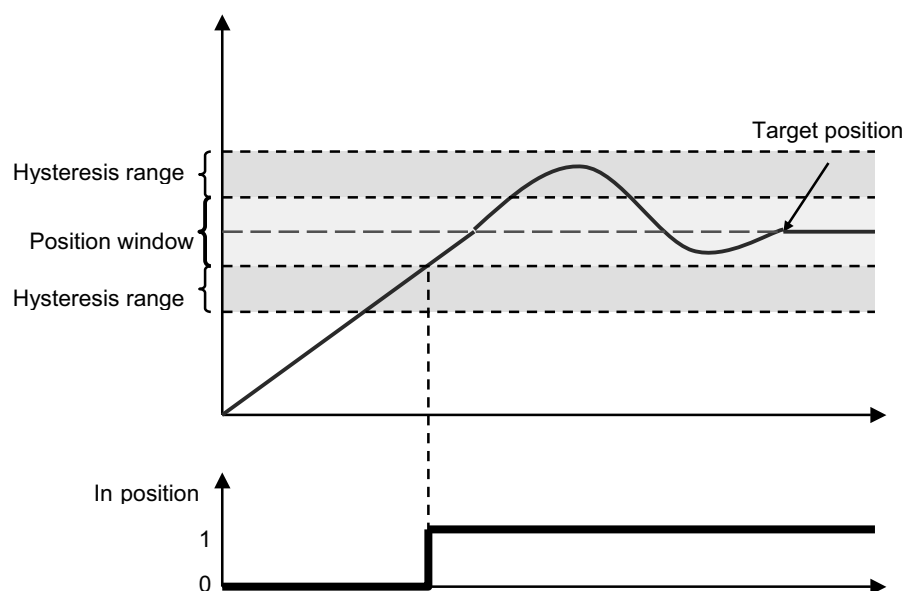

1243311243

The "In position" message operates in the FCB according to the following rules:

- It is only set by *FCB 09 Positioning* (page 134) or *FCB 12 Referencing* (page 144) when traveling to start position.
- It will not be lost if there is a change from *FCB 09* (page 134) to any other FCB, e.g. have brake applied with *FCB 13 Stop at application limit*. The change must occur within the position window and the hysteresis range.
- Goes to "0" when:
 - Leaving the position window and the hysteresis range
 - There is a new travel instruction within *FCB 09* (page 134)
 - There is a change to another FCB and it leaves the window

9885.4 In Position hysteresis

See parameter 9885.3 *In Position window* (page 136).

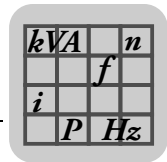

9885.5 Positioning lag error window

The positioning lag error specifies as of which lag distance (offset of setpoint position to actual position) an error should be triggered. The maximum lag distance is then divided by 2 in the positioning lag error window. The parameter only takes effect in *FCB 09 -Positioning* (page 134).

9729.18 Response to positioning lag error

Value range:

- 0 = No response
- 1 = Display only
- 5 = Output stage inhibit / waiting
- 6 = Stop at emergency stop limit / waiting
- 8 = Stop at application limit / waiting
- 10 = Stop at system limit / waiting

• **No response**

Error is ignored

• **Display only**

The 7-segment display shows the status but the axis does not respond.

• **Output stage inhibit/waiting**

The axis changes to the state output stage inhibited and applies a mechanical brake, if installed. If no brake is installed, the motor will coast to a halt. After a reset, the axis performs a warm start and is ready to operate again without delay.

• **Stop at emergency stop limit / waiting**

The motor is stopped along the emergency stop ramp. After a reset, the axis performs a warm start and is ready to operate again without delay.

• **Stop at application limit/waiting**

The motor is stopped at the application limit. After a reset, the axis performs a warm start and is ready to operate again without delay.

• **Stop at system limit/waiting**

The motor is stopped at the system limit. After a reset, the axis performs a warm start and is ready to operate again without delay.

The response is set to position lag error window exceeded.

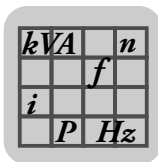

MX Parameter Description

Parameter description for FCB parameter setting

Instance data

FCB Positioning (page 134) can be assigned to an instance 64 times, e.g. for table positioning. Each instance can be then selected in the control word. This means all subsequent parameters exist 64 times in ascending order sorted by index.

This means

- instance 0 has the basic index 9886,
- instance 63 has the basic index 9949.

9886.1 – 9949.1 Operating mode

Value range:

- 0 = Absolute
- 1 = Relative
- 2 = Modulo absolute positive direction
- 3 = Modulo relative positive direction
- 4 = Modulo absolute negative direction
- 5 = Modulo relative negative direction
- 6 = Modulo shortest distance absolute
- 7 = Modulo shortest distance relative

Absolute: In this operating mode, an incoming setpoint position is approached in an absolute manner. In this case, the maximum travel range is ± 32768 motor revolutions. If higher values are specified, MOVIAXIS® will issue error 18 (internal software error).

Relative: In this operating mode, an incoming setpoint position is traveled to in a relative manner. It is recommended to use the "Accept position" bit on the control word. In this way, the position is approached in a relative manner for each edge even when the relative setpoint position does not change.

In this case, the maximum travel range is ± 32768 motor revolutions. If higher values are specified, from an absolute perspective, MOVIAXIS® will issue error 18 (internal software error). The maximum relative setpoint position that can be specified in a travel command is 32768 motor revolutions.

Modulo operating modes: In the modulo operating modes, the travel range of *9594.1 Modulo underflow* (page 54) to *9594.10 Modulo overflow* (page 53) is mapped in parameter *9839.1 Modulo position* (page 142).

Using the user-defined units (see motor startup), odd-numbered ratios can be represented infinitely, e.g. a turntable with infinite gear ratio that always moves in one direction. The modulo absolute position is always maintained between overflow and underflow independent of the drive revolutions. Reference travel must always be performed when replacing MOVIAXIS® or the motor.

- **Modulo absolute positive direction:** In this operating mode, an incoming setpoint position is approached in an absolute manner within the modulo travel range. The travel direction is always positive (looking onto the motor shaft: positive direction of rotation). The setpoint position is only valid within the modulo limits. If higher or lower values are specified, MOVIAXIS® will issue error 18 (internal software error). No more than one revolution per travel command can be moved in this operating mode. This is not a complete revolution but a revolution minus the resolution of the set user-defined unit.

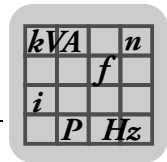

- **Modulo relative positive direction:** In this operating mode, an incoming setpoint position is approached in a relative manner within the modulo travel range. The travel direction is always positive (looking onto the motor shaft: Positive direction of rotation for parameter *8537.0 Direction of rotation reversal* (page 23) set to "OFF"). Several modulo travel ranges can be specified here (up to a maximum ± 32768 motor revolutions).
- **Modulo absolute negative direction:** Like the "Modulo absolute positive direction" operating mode but in negative direction.
- **Modulo relative negative direction:** Like the "Modulo relative positive direction" operating mode but in negative direction.
- **Modulo absolute shortest distance:** In this operating mode, the drive always travels the shortest distance within the modulo travel range. This can mean a positive or negative direction. The setpoint position is only valid within the modulo limits. If higher or lower values are specified, MOVIAXIS® will issue error 18 (internal software error).
- **Modulo relative shortest distance.**

The following settings apply to all operating modes.

The reset behavior of parameter *9998.1 Position mode* (page 114) in conjunction with absolute encoders depends on the following settings:

- If set to "**Without overflow counter**", the unit will always be positioned in the absolute range of the encoder following a CPU reset and system restart, e.g. with Hiperface® 4096 motor revolutions. This means a position loss in the event of encoder overflow. If the position range of the absolute encoder is not exceeded, no reference travel is required when replacing MOVIAXIS® because no overflows can be stored in the MOVIAXIS®. Reference travel is only required when the motor is replaced.
- When set to "**With overflow counter**", the complete ± 32768 motor revolutions are utilized despite overflow. MOVIAXIS® internally stores absolute encoder overflows. This also functions when the axis is moved to overflow without electrical current. This is ensured by checking the travel range. Reference travel must always be performed when replacing MOVIAXIS® or the motor.

9886.2 – 9949.2
*Positioning
setpoint source*

Value range: see parameter *9598.1 Velocity setpoint source* (page 123) *FCB Speed control*.

This parameter sets the source for the positioning setpoint of *FCB 09 Positioning* (page 134).

If set to "local setpoint", the source will be parameter *9886.3 – 9949.3 Positioning -setpoint local* (page 140).

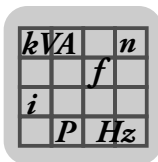

MX Parameter Description

Parameter description for FCB parameter setting

- 9886.3 – 9949.3
Local positioning setpoint
- Unit: U.
Resolution: 1/65536.
Value range: -2147483648 – 0 – 2147483647, step 1.
If the parameter 9886.2 – 9949.2 *Positioning setpoint source* (page 139) is set to "Local setpoint", this parameter will be the positioning setpoint for *FCB 09 Positioning* (page 134).
- 9886.4 – 9949.4
Max. positioning velocity positive source
- Value range: see parameter 9598.1 *Velocity setpoint source* (page 123) *FCB Speed control*.
This parameter sets the source for the positive positioning velocity of *FCB 09 -Positioning* (page 134).
If set to "local setpoint", the source will be parameter 9886.5 – 9949.5 *Local max. -positioning velocity positive* (page 140).
- 9886.5 – 9949.5
Local max. positioning velocity positive
- Unit: 10⁻³/min.
Value range: 0 – 10000000, step 1.
If parameter 9886.4 – 9949.4 *Positioning velocity positive source* (page 140) is set to "local setpoint", this parameter will be the positive velocity for *FCB 09 Positioning* (page 134).
- 9886.12 – 9949.12
Max. positioning velocity negative source
- Value range: see parameter 9598.1 *Velocity setpoint source* (page 123) *FCB Speed control*.
This parameter sets the source for the positioning velocity negative of *FCB 09 -Positioning* (page 134).
If set to "local setpoint", the source will be parameter 9886.13 – 9949.13 *Positioning -velocity negative local* (page 140).
- 9886.13 – 9949.13
Local max. positioning velocity negative
- Unit: 10⁻³/min.
Value range: 0 – 10000000, step 1.
If parameter 9886.12 – 9949.12 *Positioning velocity negative source* (page 140) is set to "local setpoint", this parameter will be the negative velocity for *FCB 09 Positioning* (page 134).
- 9886.6 – 9949.6
Max. acceleration source
- Value range: see parameter 9598.1 *Velocity setpoint source* (page 123) *FCB Speed control*.
This parameter sets the source for the positive acceleration of *FCB 09 positioning* (page 134).
If set to "local setpoint", the source will be parameter 9886.7 – 9949.7 *Acceleration -positive local* (page 141).

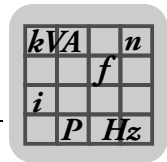

- 9886.7 – 9949.7**
Local max. velocity Unit: 10⁻²/min×s.
Value range: 0 – 300000 .. 2147483647, step 1.
If parameter **9886.6 – 9949.6** *Max. acceleration source* (page 140) is set to "local setpoint", this parameter will be the positive acceleration for *FCB 09 Positioning* (page 134).
- 9886.8 – 9949.8**
Max. deceleration source Value range: see parameter **9598.1** *Velocity setpoint source* (page 123) *FCB Speed control*.
This parameter sets the source for the deceleration of *FCB 09 positioning* (page 134).
If set to "local setpoint", the source will be parameter **9886.9 – 9949.9** *Local max. -deceleration* (page 141).
- 9886.9 – 9949.9**
Local max. deceleration Unit: 10⁻²/min×s.
Value range: 0 – 300000 .. 2147483647, step 1.
If parameter **9886.8 – 9949.8** *Deceleration source* (page 141) is set to "local setpoint", this parameter will be the deceleration for *FCB 09 Positioning* (page 134).
- 9886.10 – 9949.10**
Jerk source Value range: see parameter **9598.1** *Velocity setpoint source* (page 123) *FCB Speed control*.
This parameter sets the source for the jerk of *FCB 09 Positioning* (page 134).
If set to "local setpoint", the source will be parameter **9886.11 – 9949.11** *Local jerk* (page 141).
- 9886.11 – 9949.11**
Local jerk Unit: 1/(min×s²).
Value range: 1 – 2147483647, Step 1.
If parameter **9886.10 – 9949.10** *Jerk source* (page 141) is set to "local setpoint", this parameter will be the jerk for *FCB 09 Positioning* (page 134).
- 9704.1** *Position* Unit: U.
Resolution: 1/65536.
Value range: -2147483648 – 0 – 2147483647, step 1.
Current actual position in user-defined units, filtered for display.

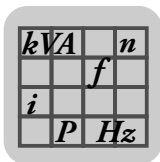

MX Parameter Description

Parameter description for FCB parameter setting

9839.1 *Modulo position*

Unit: U.

Resolution: 1/65536.

Value range: -2147483648 – 0 – 2147483647, step 1.

Current actual modulo position in user-defined units, filtered for display.

10098.2 *Lag error*

Unit: U.

Resolution:

Value range:

1.5.8 FCB 10 Interpolated positioning

The FCB 10 Interpolated positioning is used for cyclic preselected position setpoints of higher-level controllers, e.g. MotionControl.

The higher-level controller is responsible for the following limits:

- Jerk,
- Acceleration,
- Speed.

Only the speed and torque system limits take effect in MOVIAXIS®.

Prerequisite is a synchronized bus system. This means that incoming process data has a fixed time reference for the control system of the axis.

The new process data is sent within a fixed cycle time. This time must be a multiple of the cycle time of the speed control loop (parameter *9821.1 Scanning frequency n/X-control* (page 32); 250µs, 500µs or 1ms).

MOVIAXIS® now has the task of forwarding the incoming positions with a rough time reference to the operating position controller with the shortest time reference. Intermediate values must be interpolated for this purpose. The setpoint flow is delayed by one communication cycle to carry out this interpolation.

The incoming position over two process data is interpreted in user-defined units.

9963.1 *Setpoint cycle control*

Unit: µs.

Value range: 500 – 20000, step 500.

The setpoint cycle of the controller indicates the time intervals used by the higher-level controller to send position setpoints. This time must be a multiple of the cycle time of the position control loop (parameter *9821.1 Scanning frequency n/X control* (page 32)).

9966.5 *Setpoint position filter*

Unit:

Value range:

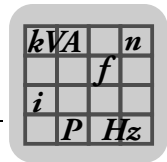

9729.18 Response to positioning lag error

- 0 = No response
- 1 = Display only
- 2 = Output stage inhibit / locked
- 3 = Stop at emergency stop limit / locked
- 5 = Output stage inhibit / waiting
- 6 = Stop at emergency stop limit / waiting
- 8 = Stop at application limit / waiting
- 9 = Stop at application limit / locked
- 10 = Stop at system limit / waiting
- 11 = Stop at system limit / locked

The response is set to position lag error window exceeded.

9966.1 Setpoint position source

Value range: see parameter *9598.1 Velocity setpoint source* (page 123) *FCB Speed control*.

This parameter sets the source for the positioning setpoint of *FCB 10 Interpolated -positioning* (page 142).

If the parameter is set to "local setpoint", the source will be parameter *9966.2 Local -position setpoint* (page 143).

9966.2 Local position setpoint

Unit: U.

Resolution: 1/65536.

Value range: -2147483648 – 0 – 2147483647, step 1.

If the parameter "Setpoint position source" is set to "local setpoint", this parameter will be the position setpoint for *FCB 10 Interpolated positioning* (page 142).

9966.4 Positioning lag error window

Unit: U.

Resolution: 1/65536.

Value range: 0 – 65536 – 2147483647, step 1.

The lag error window for positioning specifies the allowed dynamic deviation of the setpoint from the actual value in user-defined units until an error is triggered. The error response is set in parameter *9729.18 Response lag error positioning* (page 143).

9704.1 Position

Unit: U.

Resolution: 1/65536.

Value range: -2147483648 – 0 – 2147483647, step 1.

Current actual position in user-defined units, filtered for display.

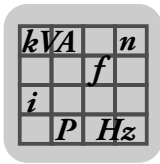

MX Parameter Description

Parameter description for FCB parameter setting

9839.1 Modulo position Unit: U.
 Resolution: 1/65536.
 Value range: -2147483648 – 0 – 2147483647, step 1.
 Current actual modulo position in user-defined units, filtered for display.

10098.2 Lag error Unit: U.
 Resolution:
 Value range:

1.5.9 FCB 12 Reference travel

Actual values

9857.1 Reference travel status Indicates the state that the reference travel is currently in.

9703.1 Velocity Unit: 10⁻³/min.
 Current actual velocity in user-defined units, filtered for display.

9704.1 Position Unit: U.
 Resolution: 1/65536.
 Value range: -2147483648 – 0 – 2147483647, step 1.
 Current actual position in user-defined units, filtered for display.

9839.1 Modulo position Current actual modulo position in user-defined units, filtered for display.
 Unit: U.
 Resolution: 1/65536.
 Value range: -2147483648 – 0 – 2147483647, step 1.

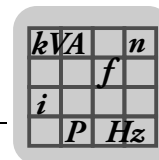

1.5.10 FCB 18 Encoder adjustment

FCB 18 Encoder adjustment is used for commutation detection for synchronous AC motors (linear and rotary). The drive must be disconnected from the load and from the gear unit. If this is not possible, or only with considerable effort, see *FCB25 Rotor position identification*. The motor must first be started up electrically.

When changing to *FCB 18 encoder adjustment*, calibration (exception: "Automatically write preset offset angle to parameter" mode) is immediately started and runs through the following states:

	<p>INFORMATION</p> <p>FCB18 should be selected directly from controller inhibit (FCB01) because all other stop FCBs (including the default FCB13) set the speed to 0. Without proper commutation, this might result in a non-controlled movement of the axis.</p>
---	--

1. **Inactive:** FCB is not selected.
2. **Current build-up:** Adjustment is started by selecting the FCB. Parameter *10054.1 Write control encoder alignment* (page 152) is set to "inactive".
3. **Wait 1:** The motor waits until the mechanical transient process at the motor shafts is finished.
4. **Turn forward:** The drive now rotates forward one revolution (as viewed from the motor shaft, positive direction of rotation). The revolution in the positive direction of rotation is very important, else the wiring may be incorrect and parameter *10054.3 Encoder adjustment status* (page 152) changes to status 10 error. The parameter *8537.0 Change direction of rotation* (page 23) reverses the direction of rotation (first negative then positive direction of rotation).
5. **Wait 2:** The motor waits until the mechanical transient process at the motor shaft is finished.
6. **Turn backward:** The motor shaft turns back to the old position.
7. **Wait 3:** The motor waits until the mechanical transient process at the motor shaft is finished.
8. **Finished:** In this condition, MOVIAXIS[®] now waits for a response from the user or higher-level controller depending on the connected motor. In the meantime, -parameter *10054.1 Measured encoder offset* (page 152) is permanently compared with the position of the motor shaft. Parameter *10054.2 Write position encoder offset* (page 152) contains the result of the measurement. There are several ways to adjust the encoder:

Mode	Description
Adjust encoder manually	→ SEW synchronous motor with resolver This mode is for manual adjustment of the encoder on the motor shaft.
Write encoder offset to Hiperface [®] encoder	→ SEW synchronous motor with Hiperface [®] After executing this mode, the data is written to the Hiperface [®] encoder. It is not necessary to open the motor.
Write encoder offset to parameter	→ Non-SEW synchronous motor After executing this mode, the measured offset is written to a parameter in MOVIAXIS [®] . This mode is independent of the encoder, as non-SEW motors are not to be changed. This ensures that it is not necessary to measure the motor again in case of service is required for the motor.

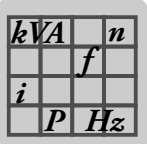

MX Parameter Description

Parameter description for FCB parameter setting

Mode	Description
Write encoder offset to parameter automatically	<p>→ Synchronous motor without absolute information (rotary and linear)</p> <p>This mode is for synchronous motors that do not have any single-turn absolute information in the encoder (e.g. Sin/Cos encoders or incremental encoders).</p> <p>The higher-level controller must select the <i>FCB18 Encoder adjustment</i> and perform a calibration run each time the unit is switched on. A prerequisite for the application is that the motor can move freely ' direct drive (rotary and linear).</p>
Automatically write preset offset angle to parameter	<p>See mode <i>Determine preset offset angle</i>.</p>
Determine preset offset angle	<p>→ Synchronous motor without absolute information (rotary and linear) with mechanically secured / always the same wake-up position (e.g. locked in place).</p> <p>This mode is for synchronous motors that do not have any single-turn absolute information in the encoder (e.g. Sin/Cos encoders or incremental encoders) and are always switched off/on in the same positions. Application examples are locking bolts upon switch-on, or hoists at the lower buffer position.</p> <p>During initial startup, the offset must be determined using the mode "Determine preset offset angle" and the subsequent calibration run.</p> <p>During each switch-on sequence, the higher-level controller must then call <i>FCB18 Encoder adjustment</i> with the mode <i>Automatically write preset offset angle to parameter</i>.</p> <p>This does not start calibration travel, but only copies a parameter.</p>

Mode description

10054.6 Mode

Mode 1: Adjust encoder manually

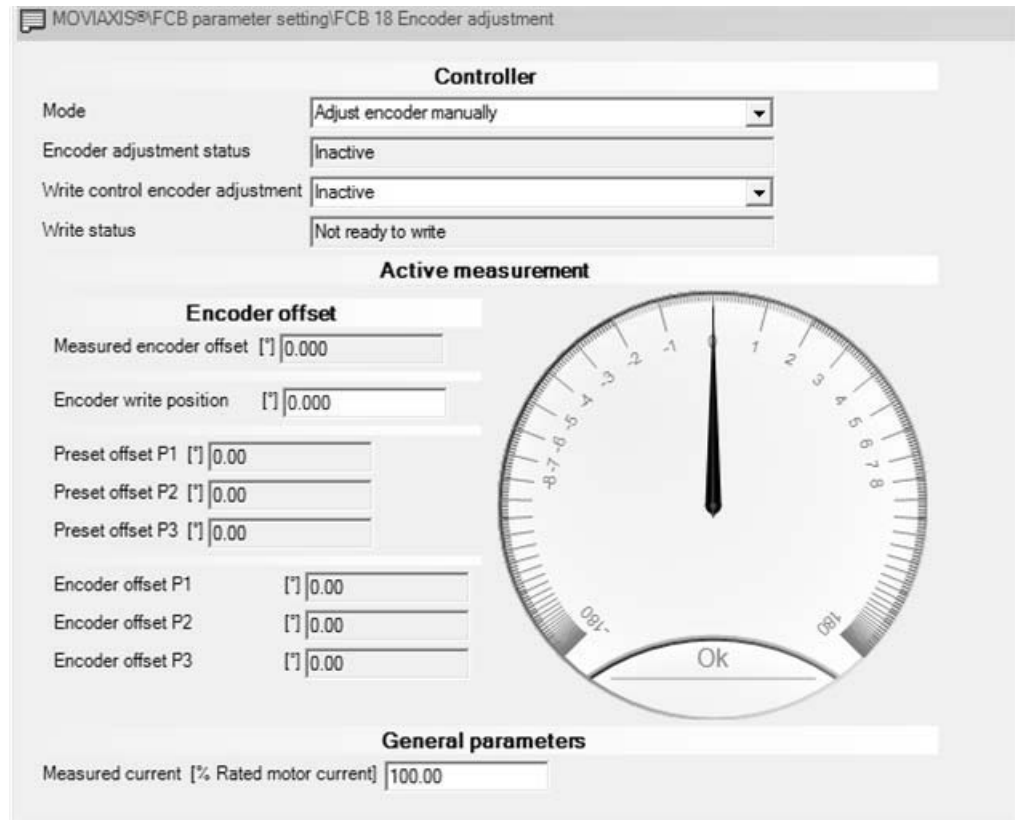

1. Set measuring current.
SEW-EURODRIVE recommends nominal motor torque as starting value (100% for basic user-defined unit torque).
Important! During the measurement, the measuring current is continuously supplied to the motor.
2. Select "Adjust encoder manually" mode
3. Select *FCB 18 Encoder adjustment* (directly from controller inhibit)
4. The encoder adjustment status runs through the states described above.
5. After the encoder adjustment status "Completed" is displayed, you can set the resolver manually to "0" using the shown clock.
6. Checking the setting by calling *FCB 18 Encoder adjustment* again.

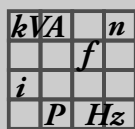

Mode 2: Write encoder offset to Hiperface® encoder

MOVIAxis® FCB parameter setting | FCB 18 Encoder adjustment

Controller

Mode: Write encoder offset to Hiperface encoder

Encoder adjustment status: Inactive

Write control encoder adjustment: Inactive

Write status: Not ready to write

Active measurement

Encoder offset

Measured encoder offset [°]: 0.000

Encoder write position [°]: 0.000

Preset offset P1 [°]: 0.00

Preset offset P2 [°]: 0.00

Preset offset P3 [°]: 0.00

Encoder offset P1 [°]: 0.00

Encoder offset P2 [°]: 0.00

Encoder offset P3 [°]: 0.00

General parameters

Measured current [% Rated motor current]: 100.00

1. Set measuring current.
SEW-EURODRIVE recommends nominal motor torque as starting value (100% for basic user-defined unit torque).
Important! During the measurement, the measuring current is continuously supplied to the motor.
2. Select "Write encoder offset to Hiperface®" mode
3. Select *FCB 18 Encoder adjustment* (directly from controller inhibit)
4. The encoder adjustment status runs through the states described above.
5. After the encoder adjustment status "Completed" is displayed, the parameter write status changes to "Ready to write".
6. Now, the parameter *Encoder adjustment write control* must be set to "Write". MOVIAxis® now writes the value displayed in parameter *Encoder write position* to the Hiperface® encoder. The value is not exactly zero. The difference is the friction caused by turning forwards and backwards.
7. MOVIAxis® starts the calibration process again to check the settings.

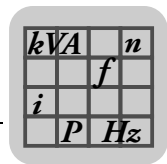

Mode 3: Write encoder offset to parameter

MOVIAXIS®FCB parameter setting|FCB 18 Encoder adjustment

Controller

Mode: Write encoder offset to parameter

Encoder adjustment status: Inactive

Write control encoder adjustment: Inactive

Write status: Not ready to write

Active measurement

Encoder offset

Measured encoder offset [°]: 0.000

Encoder write position [°]: 0.000

Preset offset P1 [°]: 0.00

Preset offset P2 [°]: 0.00

Preset offset P3 [°]: 0.00

Encoder offset P1 [°]: 0.00

Encoder offset P2 [°]: 0.00

Encoder offset P3 [°]: 0.00

General parameters

Measured current [% Rated motor current]: 100.00

1. Set measuring current.
SEW-EURODRIVE recommends nominal motor torque as starting value (100% for basic user-defined unit torque).
Important! During the measurement, the measuring current is continuously supplied to the motor.
2. Select "Write encoder offset to parameter" mode
3. Select *FCB 18 Encoder adjustment* (directly from controller inhibit)
4. The encoder adjustment status runs through the states described above.
5. After the encoder adjustment status "Completed" is displayed, the parameter write status changes to "Ready to write".
6. Now, the parameter *Encoder adjustment write control* must be set to "Write".
MOVIAXIS® now writes data to the parameter *Encoder offset P1 – P3* (depending on the parameter set).
7. MOVIAXIS® starts the calibration process again to check the settings.

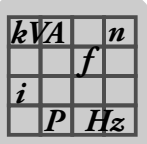

Mode 4: Write encoder offset to parameter automatically

MOVIAXIS®FCB parameter setting|FCB 18 Encoder adjustment

Controller

Mode: Automatically write encoder offset to parameter

Encoder adjustment status: Inactive

Write control encoder adjustment: Inactive

Write status: Not ready to write

Active measurement

Encoder offset

Measured encoder offset [°]: 0.000

Encoder write position [°]: 0.000

Preset offset P1 [°]: 0.00

Preset offset P2 [°]: 0.00

Preset offset P3 [°]: 0.00

Encoder offset P1 [°]: 0.00

Encoder offset P2 [°]: 0.00

Encoder offset P3 [°]: 0.00

General parameters

Measured current [% Rated motor current]: 100.00

The mode *Write encoder offset to parameter automatically* has the same function as the mode *Write encoder offset to parameter*.

The difference is point 6. Data is not written to the parameter *Encoder offset P1 – P3* by *Encoder adjustment write control*, but automatically after the calibration has been completed.

Mode 5: Write preset offset to parameter automatically

A prerequisite for this mode is that the *preset offset* has been determined once with the mode *Determine preset offset angle*. After that, *FCB 18 Encoder adjustment* must be selected once after each switch-on sequence with this mode.

See mode "Determine preset offset angle".

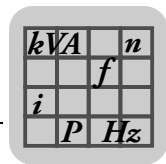

Mode 6: Determine preset offset angle

1. Move drive to wake-up position (the wake-up position should be always the same to use this mode)
2. Switch the unit on (apply 24 V)
3. Set measuring current
SEW-EURODRIVE recommends nominal motor torque as starting value (100% for basic user-defined unit torque).
Important! During the measurement, the measuring current is continuously supplied to the motor.
4. Select *Determine preset offset angle* mode
5. You can now move the drive away from the wake-up position to an area in which it can move freely for commutation travel. It is important that the axis remains switched on (distance measuring by encoder must be ensured). The commutation travel can be executed at any point.
6. Select *FCB 18 Encoder adjustment* (directly from controller inhibit)
7. The encoder adjustment status runs through the states described above.
8. The measured encoder offset is copied to the parameter *Preset offset* before the encoder adjustment status "Completed" is displayed.

It must be ensured before each switch-on that the drive is in the defined wake-up position. Then, a higher-level controller must select FCB18 Encoder adjustment with mode "Write preset offset angle to parameter automatically". Now, the axis is ready for operation.

The status bit *Motor commutated* can deliver feedback.

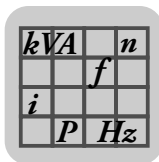

MX Parameter Description

Parameter description for FCB parameter setting

Parameter description

10054.3 Encoder adjustment status

Value range:

- 0 = Inactive
- 1 = Current generation
- 2 = Waiting 1
- 3 = Rotate forward
- 4 = Waiting 2
- 5 = Rotate backwards
- 6 = Waiting 3
- 7 = Copy
- 8 = Do not copy
- 9 = Finished
- 10 = Error

10054.4 Write control encoder adjustment

Value range:

- 0 = Inactive
- 1 = Do not copy
- 2 = Write

Inactive: The FCB basically starts with this setting. If the parameter is set to another setting, it will be reset to "inactive".

No copy: This setting is only used for special purposes to write an arbitrary encoder offset to the Hiperface® encoder.

Write: With this setting, the parameter *10054.1 Measured encoder offset* (page 152) will be written to the Hiperface® encoder.

10054.7 Write status

Value range:

- Not ready to write
- Ready to write
- Writing in progress
- Write process finished

10054.1 Measured encoder offset

Unit: U.

Resolution: $1/2^{32}$.

Currently measured encoder offset for which the encoder shaft has an incorrect setpoint setting. (360° corresponds to one mechanical revolution).

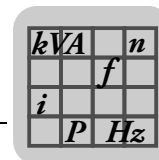

10054.2 Encoder write position Unit: U.
Resolution: 1/65536.
Value range: 0 – 4294967295, step 1.
This value is written for "Encoder adjustment write control = Write" to a Hiperface® encoder. The inaccuracy of "0" is determined by the friction compensation.

10054.11 / 12 / 13 Preset offset P1 – P3 See table above on the *Determine preset offset angle* mode.

9834.1 / 2 / 3 Encoder offset P1 – P3 See table above on the *Write encoder offset to parameter* mode.

10054.5 Measuring current Unit: %.
Resolution: 10⁻³.
Value range: 0 – 100000 – 1000000, step 1.
The measuring current must be set in the user-defined units of the torque. It must not exceed the nominal motor torque.

1.5.11 FCB 20 Jog mode

MOVIAXIS® has a position-controlled jog mode function; this means it is possible to move an axis in positive or negative direction, for example, for alignment purposes in **position-controlled** mode using two adjustable speeds for each. The advantage of this function is that it can be used with hoist applications for which the position is not permitted to change when a change in load occurs when the drive is at a standstill.

Setpoints

9604.10 Select set of jog velocities Resolution:
Value range:

9604.12 Velocity 1 positive source Resolution:
Value range:

9604.1 Velocity 1 positive local Unit: rpm
Resolution: 10⁻³.
Value range: 0 – 1000000, step 1.
Positive speed setpoint in user-defined units (as seen onto the motor shaft, positive direction of rotation).

9604.13 Velocity 1 negative source Resolution:
Value range:

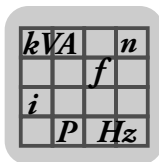

MX Parameter Description

Parameter description for FCB parameter setting

9604.2 Velocity 1 <i>negative local</i>	<p>Unit: rpm</p> <p>Resolution: 10^{-3}.</p> <p>Value range: 0 – 1000000, step 1.</p> <p>Negative speed setpoint in user-defined units (as seen onto the motor shaft, negative direction of rotation).</p>
9604.8 Velocity 2 <i>positive</i>	<p>Unit: rpm</p> <p>Resolution: 10^{-3}.</p> <p>Value range: 0 – 1000000, step 1.</p> <p>Positive speed setpoint in user-defined units (as seen onto the motor shaft, positive direction of rotation).</p>
9604.9 Velocity 2 <i>negative</i>	<p>Unit: rpm</p> <p>Resolution: 10^{-3}.</p> <p>Value range: 0 – 1000000, step 1.</p> <p>Negative speed setpoint in user-defined units (as seen onto the motor shaft, negative direction of rotation).</p>
<i>Limit values</i>	
9604.14 Acceleration source	<p>Resolution:</p> <p>Value range:</p>
9604.5 Acceleration	<p>Resolution: $10^{-2}/(\text{min}\times\text{s})$.</p> <p>Value range: 0 – 300000 – 2147483647, step 1.</p> <p>Jog acceleration in user-defined unit.</p>
9604.15 Deceleration source	<p>Resolution:</p> <p>Value range:</p>
9604.6 Deceleration	<p>Resolution: $10^{-2}/(\text{min}\times\text{s})$.</p> <p>Value range: 0 – 300000 – 2147483647, step 1.</p> <p>Jog acceleration in user-defined unit.</p>
9604.16 Jerk source	<p>Resolution:</p> <p>Value range:</p>
9604.7 Jerk	<p>Resolution: $10^{-2}/(\text{min}\times\text{s}^2)$.</p> <p>Value range: 1 – <u>2147483647</u>, Step 1.</p> <p>Jerk in user-defined unit for jog mode.</p>

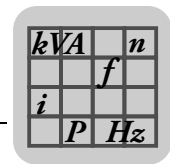

9604.17 Lag error window The *Jog* lag error window specifies as of which lag distance (offset of setpoint position to actual position) an error will be triggered. The maximum lag distance is then *lag error window divided by 2*. The parameter is only effective in *FCB20 Jog*.

9604.18 Jog lag error response Value range: 0 – 1 – 5

- 0 = No response
- 1 = Display only
- 5 = Output stage inhibit / waiting

Actual values

10120.1.1 Velocity Unit: 10⁻³/min
Current actual velocity in user-defined units, filtered for display.

9704.1 Position Unit: U.
Resolution: 1/65536.
Current actual position in user-defined units, filtered for display.

9839.1 Modulo position Unit: U.
Resolution: 1/65536.
Value range: -2147483648 – 0 – 2147483647, step 1.
Current actual modulo position in user-defined units, filtered for display.

1.5.12 FCB 21 Brake test

This function is used to check the braking capability of a brake connected to MOVIAXIS®. A test torque is applied electrically via the motor when the brake is applied.

Even when the brake has passed the brake test, it does not take on any safety functions as far as machine safety is concerned in combination with MOVIAXIS®.

The brake is only tested in accordance with the set brake test torque. The actual "brake breakaway torque" is not measured.

MOVIAXIS® supports four test modes:

1. A higher-level controller provides the setpoints and monitoring function for the test.
2. MOVIAXIS® performs a check in both directions compared to the set limit torques.
3. MOVIAXIS® performs a check in positive direction compared to the set limit torques.
4. MOVIAXIS® performs a check in negative direction compared to the set limit torques.

The test torque, test time and the direction of rotation of the test can be set. If a test is not passed, the breakaway torque is documented.

The brake is considered to be "ok" when the motor shaft does not move more than 10°. This is a fixed value.

IMPORTANT: The function does not check whether a brake is actually installed. If the brake test is activated when a brake is not installed, the drive will move depending on the brake test mode.

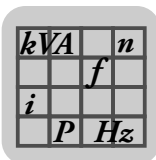

MX Parameter Description

Parameter description for FCB parameter setting

The braking torque is limited by the set *Torque system limit*. Note: The application torque must be considered for calculating the test torque, e.g. hoist test "downward".

	INFORMATION
	When the brake has passed the brake test, it does not take on any safety functions as far as machine safety is concerned in combination with MOVIAXIS®.
	A check is not made to determine whether a brake is physically present. This means that the brake test would also be performed without a brake. This allows for the testing of external brakes.

9600.1 Test

Value range:

- 1 = External setpoint selection
- 2 = Bipolar torque
- 3 = Positive torque
- 4 = Negative torque

External setpoint selection

In this mode, the brake test is completely evaluated by a higher-level controller / PLC. The brake test is running as long as the FCB is active. Possible travel movements are not monitored.

Only the parameters for the speed setpoint "9600.4 (page 157) and 9600.5 (page 157)" and test torque "9600.2 (page 157) and 9600.3 (page 157)" are used. All other parameters are used in test modes 2 to 4 only.

Bipolar, positive and negative torque mode

In this mode, the brake test is completely evaluated and reported back by MOVIAXIS®.

Brake slipping, even when minimal, generates axis movement in the test direction. When this movement exceeds one motor revolution, the brake is output as an error type in parameter *9600.8 Status* (page 157). Only the system limits are effective for the *FCB brake test* (page 155).

Use the test mode "bipolar", "positive" or "negative" depending on the application.

The duration of the set test torque can be set using parameter *9600.6 Test duration* (page 158). The test result is stored in parameter *9600.8 Status* (page 157) after successful completion of the test.

Parameter *9600.4 Setpoint speed* (page 157) is not effective.

If a brake test is interrupted, an error message will be issued. Speed monitoring is deactivated for the duration of the brake test.

- Bipolar: Positive and negative test torque (brake test is performed twice)
- Positive: Operated only with a positive test torque
- Negative: Operated only with a negative test torque

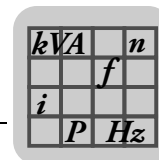

9600.7 Error response Value range: See parameter *9729.16 Response external error* (page 75).
 This parameter is used to set the error response for the axis after a faulty brake test.

9600.8 Status Value range: 0 – 4294967295, step 1.
 The following states can be displayed:

- No calibration.
- Calibration in progress.
- Calibration was aborted.
- Brake OK.
- Brake faulty.

Brake "ok" or "faulty" can also be read in the status word.

Setpoints

9600.4 Speed setpoint source Only mode 1.
 Value range: see parameter *9598.1 Velocity setpoint source* (page 123) *FCB Speed control*.
 This parameter sets the source for the speed setpoint of *FCB 21 brake test* (page 155).
 If the parameter is set to "local setpoint", the source will be parameter *9600.4 Local speed setpoint*.

9600.5 Local speed setpoint Only mode 1.
 Resolution: 10⁻³.
 Value range: -1000000 – 0 – 1000000, step 1.
 If parameter *9600.4 Speed setpoint source* (page 157) is set to "local setpoint", this parameter will be the speed setpoint for the *FCB 21 Brake test* (page 155).

Limit values

9600.2 Test torque source Value range: see parameter *9598.1 Velocity setpoint source* (page 123) *FCB Speed control*.
 This parameter sets the source for the test torque of *FCB 21 Brake test* (page 155).
 If the parameter is set to "local setpoint", the source will be parameter *9600.3 Local test torque* (page 157).
 The test torque cannot be changed during the test run. The test torque should be based on the brake torque in conjunction with the static load torque.

9600.3 Local test torque Unit: %.
 Resolution: 10⁻³.
 Value range: 0 – 100000 – 1000000, step 1.
 If parameter *9600.2 Test torque source* (page 157) is set to "local setpoint", this parameter will be the test torque for *FCB 21 Brake test* (page 155) in user-defined units.

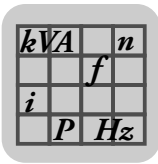

MX Parameter Description

Parameter description for FCB parameter setting

9600.6 Test duration

Only modes 2 – 4.

Unit: ms.

Value range: 0 – 1000 – 5000, step 1.

The test time is indicated in mode 2 – 4 for the duration of the test. Afterwards "ok" or "faulty" is displayed in brake status.

SEW-EURODRIVE recommends a test time of 1 second.

9600.9 Protocol torque

Only modes 2 – 4.

Unit: %.

Resolution: 10^{-3} .

Value range: 0 – 1000000, step 1.

If the brake is faulty, the protocol torque shows the slip torque in user-defined units in mode 2 – 4.

Actual values

9985.1 User-defined unit torque

Unit: %.

Resolution: 10^{-3} .

Value range: -2147483648 – 2147483647, step 1.

Current torque in user-defined units, filtered for the display.

kVA	n
	f
i	
P	Hz

1.5.13 FCB 22 Multi-drive

FCB Multi-drive is used to operate 2, 3 or 4 motors on a load in the mode "interpolated speed control" (like FCB 6). The drives can be mechanically coupled or not. The mechanical coupling can also be temporary. Working against each other like rigidly coupled synchronized drives is not possible due to the functional principle.

The FCB Multi-drive does not work according to the master-slave principle, but all drives are equal. They receive the same speed setpoint from a higher-level controller and the balance their position via lateral axis-to-axis communication. This position balancing is given priority, even in case an axis (due to an error) or several axes (due to the torque control limit) can no longer follow the preset speed setpoint. This can mean, for example, that 3 axes coast to a halt along the one axis that is in error status.

Process data exchange for two motors (dual drive)

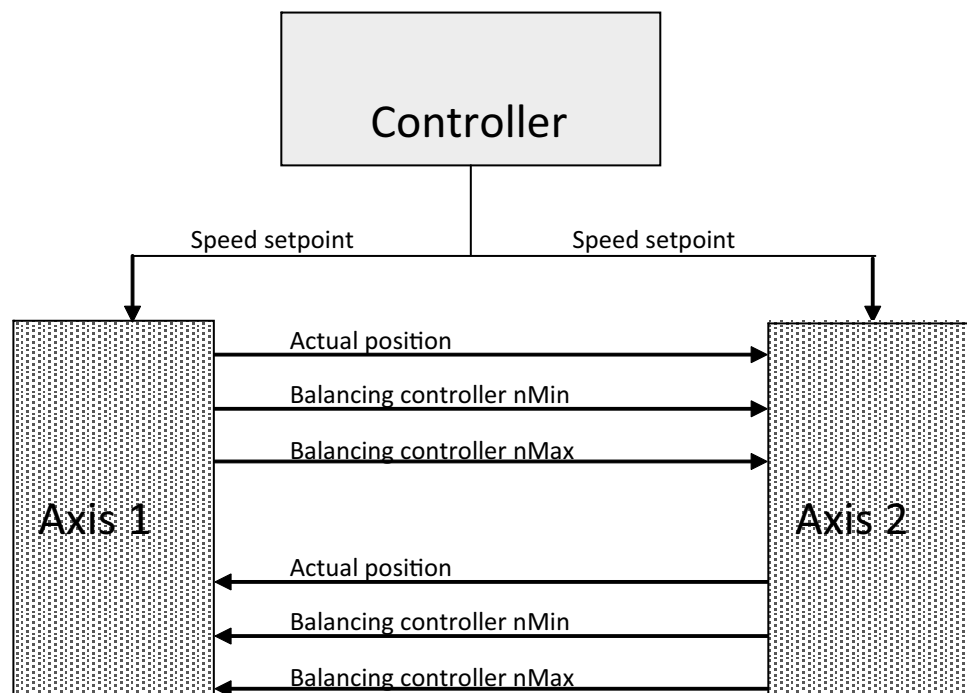

The process data exchange is configured via the PDO Editor. Each axis sends its data synchronously via the system bus. In the same cycle, each axis receives the data of the respective remote axis.

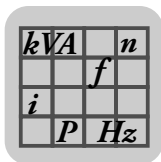

MX Parameter Description

Parameter description for FCB parameter setting

Triple or quadruple injection

The process data exchange of triple or quadruple injection is similar to that of the dual drive.

The speed setpoint is addressed to 3 or 4 axes accordingly. In contrast to double injection, the lateral communication is designed in such a way that each of the 4 axes sends and receives the "actual position", "balancing controller nMin" and "balancing controller nMax".

This means that the balancing controller data of each axis is cyclically available to all 3 other axes. For balancing control, the average is determined from this data.

Position balancing controller

A position balancing controller is implemented to ensure position synchronicity. A prerequisite for useful operation is that all axes are referenced correctly.

Each axis determines the differences between its own position and the positions of each of the other axes. The positions of the two axes can be offset from each other by a defined value via an offset parameter (10052.7). The leading axis must receive the offset as a negative value, the lagging axis as a positive value.

The parameters on both axes must receive the same amount, but a different sign. If this is not the case, the actual speed can deviate from the speed setpoint.

If more than two axes are used as multi-drive, the sum of the offset parameters (10052.7) across all axes must be zero.

Speed setpoint limit

The position balancing controller can only work properly as long as the drive are not at the control limit. If the setpoint speed deviates from the actual speed, the control variable of the position balancing controller is no longer fully effective, or not at all. Position balancing is no longer fully realized. To prevent this, the speed setpoint is limited before the control value of the position balancing controller is activated.

The speed setpoints are limited in such a way that the drive with the higher torque demand is operating exactly at the torque control limit. For this purpose, all axes determine the minima (maxima) of nmax (nmin) of the local values and the remote values.

Initialization phase of FCB 22 Multi-drive

After activating FCB22 in the control word, this FCB is in *Position balancing* mode. Here, it checks whether the position is outside the *Lag error window dual drive adjustment phase* (10052.26). If this is true, the following error is reported:

E21.1: "Lag error during adjustment phase".

If this is not true, the position deviation is corrected. The required maximum travel speed can be set in parameter *Maximum synchronization speed* (10052.27). The synchronization speed is superimposed on the specified speed setpoint.

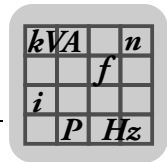

If the lag error falls below the value of the *Lag error window* parameter (10052.9), the unit changes to *Standard* mode. As of this moment, the *Lag error window dual drive adjustment phase* (10052.26) becomes inactive, and the *Lag error window* (10052.9) becomes effective.

If the position deviation exceeds this value, the following error is triggered:

E21.2: "Lag error in standard operation".

The response of the axis to this error can be parameterized via *Lag error response* (10052.8).

The parameters for defining the lag error windows are checked for plausibility. The following errors can occur:

E 16.1034: *Lag error window position adjustment* (10052.26) must be larger than *Lag error window dual drive* (10052.9).

E 16.1035: *Lag error window dual drive* (10052.9) must be larger than *Position adjustment threshold* (10052.25).

Parameter description

9963.1 Setpoint cycle control

Unit: ms
Resolution:
Value range: 0.5 – 20
Cycle of speed setpoints from the higher-level controller.

10052.1 Setpoint cycle lateral communication for position balancing

Unit: ms
Resolution:
Value range: 1 ms is fixed, cannot be selected

10052.2 P-gain position balancing controller

Unit: 1/s
Resolution: 0.001 1/s
Value range: 0 – 20 – 10000

10052.27 Maximum synchronizing speed

Unit: User-defined unit velocity
Resolution:
Value range: 0

10052.25 Threshold position adjustment

Unit: User-defined unit position
Resolution:
Value range: 0.5 motor revolutions

10052.26 Lag error window dual drive adjustment phase

Unit: User-defined unit position
Resolution:
Value range: 2 motor revolutions

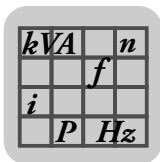

MX Parameter Description

Parameter description for FCB parameter setting

10052.3 *Velocity setpoint source*

Unit:

Resolution:

Value range:

- Local setpoint
- IN process data channel 00 – 15
- Application limit torque

10052.4 *Local velocity setpoint*

Unit: User-defined unit velocity

Resolution:

Value range: 0

10052.7 *Position difference*

Unit: User-defined unit position

Resolution:

Value range: 0

10052.28 *FCB 22 Mode*

Unit:

Resolution:

Value range:

- Deactivated
- 2-axis mode
- 3-axis mode
- 4-axis mode

10060.1 / 2 / 3
Source of minimum speed balancing controller remote axis 1/2/3

Unit:

Resolution:

Value range:

- Local setpoint
- IN process data channel 00 – 15
- Application limit torque

10059.1 / 2 / 3
Source of maximum speed balancing controller remote axis 1/2/3

Unit:

Resolution:

Value range:

- Local setpoint
- IN process data channel 00 – 15
- Application limit torque

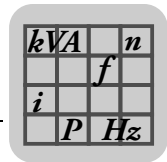

10052.5 Position balancing setpoint source

Unit:
Resolution:
Value range:

- Local setpoint
- IN process data channel 00 – 15
- Application limit torque

10052.30 / 32 FCB Position balancing source

Unit:
Resolution:
Value range:

- Local setpoint
- IN process data channel 00 – 15
- Application limit torque

10052.8 Lag error response

Unit:
Resolution:
Value range:

- No response
- Display only
- Stop at application limit/waiting
- Emergency stop/waiting
- Stop at system limit/waiting
- Output stage inhibit/waiting

10052.9 Lag error

Unit: User unit
Resolution:
Value range: 1 motor revolution

10052.10 Current lag error dual drive

Unit: User unit
Resolution:
Value range:

10052.11 Torque limitation mode

Unit:
Resolution:
Value range:

- Single channel
- Dual channel
- Quadruple channel

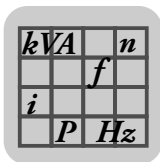

MX Parameter Description

Parameter description for FCB parameter setting

10052.12 / 14 /
16 / 18 Torque
limit 1 / 2 / 3 / 4
source

Unit:
Resolution:
Value range:

- Local setpoint
- IN process data channel 00 – 15
- Application limit torque

10052.13 / 15 /
17 / 19 Torque
limit 1 / 2 / 3 / 4
local

Unit: User-defined unit torque
Resolution:
Value range:

10052.22 Positive
transition mode

Unit:
Resolution:
Value range:

- Center
- Motor
- Regenerative

10052.20 Positive
transition speed

Unit: User-defined unit velocity
Resolution:
Value range:

10052.23 Negative
transition mode

Unit:
Resolution:
Value range:

- Center
- Motor
- Regenerative

10052.21 Negative
transition speed

Unit: User-defined unit velocity
Resolution:
Value range:

10120.1 Velocity

Unit: Current actual velocity in user-defined units
Resolution:
Value range:

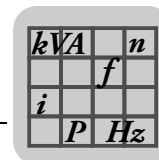

1.5.14 FCB 25 Rotor position identification

FCB25 Rotor position identification is used for commutation detection for synchronous AC motors (linear and rotary). In contrast to *FCB18 Encoder adjustment*, it is not necessary to separate the drive from the load or the gear unit. *FCB25 Rotor position identification* is a commutation at standstill that can be performed even when the brake is applied.

FCB25 can only be used with certain types of SEW-EURODRIVE motors:

- CMP71, CMP80, and CMP100
- CFM motors
- DS motors

Another requirement for using this function is that you have to determine correction factors for the individual motors which are written to MOVIAXIS® during motor startup.

The complete list of correction factors was not available when this publication went to press. Please contact SEW-EURODRIVE for a copy. However, without this information, you can simply select FCB25 for any motor.

If no correction factors are available in MOVIAXIS®, the axis will change to error status. There is no risk of an operating error.

The motor must first be started up electrically.

When switching to *FCB25 Rotor position identification*, the calibration process is started immediately!

	<p>INFORMATION</p> <p>FCB25 should be selected directly from controller inhibit (FCB01) because all other stop FCBs (including the default FCB13) set the speed to 0. Without proper commutation, this might result in a non-controlled movement of the axis.</p>
--	--

Mode	Description
Adjust encoder manually	→ SEW synchronous motor with resolver This mode is for manual adjustment of the encoder on the motor shaft
Write encoder offset to writeable encoder	→ SEW synchronous motor with Hiperface® After executing this mode, the data is written to the Hiperface® encoder. It is not necessary to open the motor.
Write encoder offset to parameter	→ Non-SEW synchronous motor After executing this mode, the measured offset is written to a parameter in MOVIAXIS®. This mode is independent of the encoder, as non-SEW motors are not to be changed. This ensures that it is not necessary to measure the motor again in case of service is required for the motor.
Write encoder offset to parameter automatically	→ Synchronous motor without absolute information (rotary and linear) This mode is for synchronous motors that do not have any single-turn absolute information in the encoder (e.g. Sin/Cos encoders or incremental encoders). The higher-level controller must select the FCB18 Encoder adjustment and perform a calibration run each time the unit is switched on. The application must allow the motor to move freely → direct drive (rotary and linear).

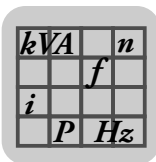

MX Parameter Description

Parameter description for FCB parameter setting

Mode description

10438.3 Mode

Mode 1: Adjust encoder manually

MOVIAXIS®\FCB parameter setting\FCB 25 Rotor position identification

Controller

Mode:

Write control:

Write status:

Wait time to write operation [s]:

Active measurement

Encoder offset

Measured encoder offset [°]:

Encoder offset P1 [°]:

Encoder offset P2 [°]:

Encoder offset P3 [°]:

System characteristics

Measured current [A]:

PIMeasureAct [%]:

Idq [%]:

Y0 [AVs]:

DeltaY / Y0 [%]:

1. Select *Adjust encoder manually* mode
2. Select *FCB25 Rotor position identification* (directly from controller inhibit)
3. After the status *Encoder adjustment completed* is displayed, you can set the resolver manually to "0" using the shown clock.
4. Checking the setting by calling *FCB25 Rotor position identification* again.

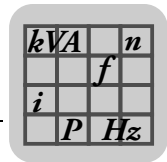

Mode 2: Write encoder offset to writeable encoder

Controller	
Mode	Write encoder offset to writeable encoder
Write control	Do not write
Write status	Not ready to write
Wait time to write operation [s]	5.0

Encoder offset	
Measured encoder offset [°]	0.00
Encoder offset P1 [°]	0.00
Encoder offset P2 [°]	0.00
Encoder offset P3 [°]	0.00

System characteristics	
Measured current [A]	0.00
PIMeasureAct [%]	0.0
Idq [%]	0.0
Y0 [AVs]	0.0
DeltaY / Y0 [%]	0.0

1. Select *Write encoder offset to writeable encoder* mode
2. Select *Adjust encoder manually* mode
3. Select *FCB25 Rotor position identification* (directly from controller inhibit)
4. After the status *Encoder adjustment completed* is displayed, you can set the resolver manually to "0" using the shown clock.
5. Checking the setting by calling *FCB25 Rotor position identification* again.

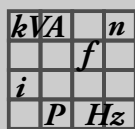

MX Parameter Description

Parameter description for FCB parameter setting

Mode 3: Write encoder offset to parameter

MOVIAXIS®FCB parameter setting\FCB 25 Rotor position identification

Controller		
Mode		Write encoder offset to parameter
Write control		Do not write
Write status		Not ready to write
Wait time to write operation [s]		5,0

Active measurement		
Encoder offset		
Measured encoder offset [°]		0,00
Encoder offset P1 [°]		0,00
Encoder offset P2 [°]		0,00
Encoder offset P3 [°]		0,00
System characteristics		
Measured current [A]		0,00
PIMeasureAct [%]		0,0
Idq [%]		0,0
Y0 [A/Vs]		0,0
DeltaY / Y0 [%]		0,0

- Select *Write encoder offset to parameter* mode
- Select *Adjust encoder manually* mode
- Select *FCB25 Rotor position identification* (directly from controller inhibit)
- After the status *Encoder adjustment completed* is displayed, you can set the resolver manually to "0" using the shown clock.
- Checking the setting by calling *FCB25 Rotor position identification* again.

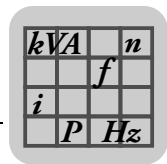

Mode 4: Write encoder offset to parameter automatically

The screenshot shows the MOVIAxis FCB parameter setting interface. The title bar reads "MOVIAxis®FCB parameter setting|FCB 25 Rotor position identification".

Controller

- Mode: Automatically write encoder offset to parameter
- Write control: Do not write
- Write status: Not ready to write
- Wait time to write operation [s]: 5.0

Active measurement

Encoder offset

- Measured encoder offset [°]: 0.00
- Encoder offset P1 [°]: 0.00
- Encoder offset P2 [°]: 0.00
- Encoder offset P3 [°]: 0.00

System characteristics

- Measured current [A]: 0.00
- PIMeasureAct [%]: 0.0
- Idq [%]: 0.0
- Y0 [AVs]: 0.0
- DeltaY / Y0 [%]: 0.0

The mode *Write encoder offset to parameter automatically* has the same function as the mode *Write encoder offset to parameter*.

The difference is that data is not written to the parameter *Encoder offset P1 – P3* by *Encoder adjustment write control*, but automatically after the calibration has been completed.

Parameter description
10438.4 Write control

Unit:

Resolution:

Value range:

- 0 = Inactive

The FCB always starts with this setting. If the parameter is set to another setting, it will be reset to "inactive".

- 1 = Do not copy

This setting is only used for special purposes to write an arbitrary encoder offset to the writeable encoder.

- 2 = Write

With this setting, the parameter "10438.1 Measured encoder offset" will be written to the writeable encoder.

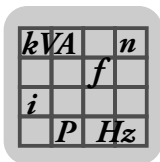

MX Parameter Description

Parameter description for FCB parameter setting

10438.10 Write status

Unit:
Resolution:
Value range:

- Not ready to write
- Ready to write
- Writing in progress
- Write process finished

10438.3 Wait time to write operation

Unit: s
Resolution:
Value range:

10438.1 Measured encoder offset

Unit: °
Resolution:
Value range:
Currently measured encoder offset for which the encoder shaft has an incorrect setpoint setting (360° corresponds to one mechanical turn).

9834.1 / 2 / 3
Encoder offset P1
– P3

Unit:
Resolution:
Value range:
See *Write encoder offset to parameter mode*.

1.5.15 FCB 26 Stop at user limits

FCB26 Stop at user limits is used for stops at user limits that initiate the deceleration ramp, either as a local setpoint or set via fieldbus.

You can choose between a speed-controlled ramp and a position-controlled ramp. In contrast to other stop FCBs, this *FCB26 Stop at user limits* has a very low priority.

This allows you to select FCB26 as standard (e.g. bit in the control word that selects this FCB is always TRUE). If all other FCBs are deactivated, FCB26 always becomes active. This makes it possible to always stop with position control.

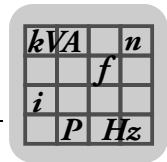

Parameter description

10445.5 Stop with position control

Unit:
Resolution:
Value range:

- Yes
The drive decelerates with position control and then stops in hold control mode
- No
The drive decelerates with position control and then stops at zero speed.

10445.1 Deceleration source

Unit:
Resolution:
Value range:
This parameter sets the source for the deceleration of *FCB Stop at user limits*.
If the parameter is set to "Local setpoint", the deceleration ramp will be parameter *10445.2 Deceleration local*.

10445.2 Deceleration local

Unit: 1/min×s
Resolution:
Value range:
Maximum deceleration in user-defined units.

10445.3 Jerk source

Unit:
Resolution:
Value range:
This parameter sets the source for the jerk of *FCB 26 Stop at user limits*.
If set to "local setpoint", the source will be parameter *10445.4 Local jerk*.

10445.4 Local jerk

Unit: 1/min×s×s
Resolution:
Value range:
Maximum jerk.

10445.6 Bit 0 stop with position control active

Unit:
Resolution:
Value range:
Status information about parameter *10445.5 Stop with position control* (mirror).

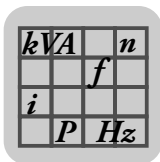

MX Parameter Description

Parameter description for unit functions

- 10120.1 Velocity** Unit: User-defined units for speed
 Resolution:
 Value range:
 Current actual speed.
- 9704.1 Position** Unit: User-defined units for actual position
 Resolution:
 Value range:
 Current actual position.
- 9839.1 Position modulo** Unit: User-defined units for actual modulo position
 Resolution:
 Value range:
 Current actual modulo position with the set modulo limits:
- Parameter "9594.10 Modulo overflow"
 - Parameter "9594.1 Modulo underflow"

1.6 Parameter description for unit functions

1.6.1 Setup

- 9702.4 Active parameter set** Value range:
- 0 = None
 - 1 = Parameter set 1
 - 2 = Parameter set 2
 - 3 = Parameter set 3
- Displays current parameter set.
- 10065.1 Select parameter set** Value range:
- 0 = No action
 - 1 = Data set 1
 - 2 = Data set 2
 - 3 = Data set 3
- Select parameter set.
- 9982.1 Software activation** Value range:
- 0 = Standard
 - 1 = Special function
- Software activation.
- This parameter is currently without function. Preparations are being made to differentiate between different software functions in the future.
- The aim is to switch functions, which require a lot of computer processor power, on and off.

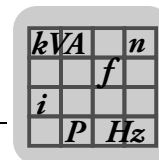

Reset unit parameters

9873.1 Active factory setting

Value range:

- 0 = None
- 1 = Basic initialization
- 2 = Delivery state
- 3 = Factory setting
- 4 = Customer set 1
- 5 = Customer set 2

Active factory setting.

This parameter shows the currently processed reset setting.

9727.3 Delivery state "d1"

Value range:

- 0 = No
- 1 = Yes

Delivery state

Activating this function will restore the delivery state of all parameters.

9727.4 Factory setting "d2"

Value range:

- 0 = No
- 1 = Yes

Factory setting.

Same as parameter "9727.3 Delivery state d1" (page 173) however, the parameters set at motor startup are not set to default values.

The factory setting does not include:

- Motor data (for example, inductances)
- Both lists of the customer-specific factory setting, see parameter "9727.2 Customer-specific factory setting d3/d4" (page 173).

The setting can be used to not having to start up the motor again.

8596.0 Reset statistics data

Value range: 0 – 3

- 0 = No action
- 3 = Operating hours

The parameter *Reset statistics data* resets the two parameters *8328.0 ON hours* and *8329.0 Enable hours* back to zero.

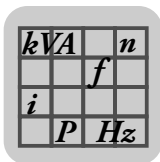

MX Parameter Description

Parameter description for unit functions

Passwords

MOVIAXIS® offers a range of access levels for access to the unit parameters. These levels include write and read authorization or, for example, read only authorization. The different levels can be protected by passwords.

The passwords can be changed, for example, to allow end customers access to specific parameters only.

At present, the following access levels are available:

1. Observer

The parameters can only be read and displayed.

2. Planning engineer

A PLANNING ENGINEER is a specialist who has complete access to all unit functions.

3. OEM

The authorization level OEM-SERVICE can be used, for example, to reset internal counters, program serial numbers, or import new firmware.

9591.50 Current password level

Value range: 0 – 4294967295, step 1.

- 20 = Lowest (observer)

Is activated if the "planning engineer" password is active, see parameter 9591.20 *Change planning engineer password* (page 174).

- 40 = Medium level (operator = planning engineer)

If the "planning engineer" password is not activated or the "planning engineer" password was entered after a reset.

- 60 = Highest (OEM service)

Is reached by entering the OEM password. The OEM password can also be used to change a forgotten "planning engineer" password, see parameter 9591.20 *Change planning engineer password* (page 174).

Current password level.

This level is used to influence the write capability of parameters. When the product leaves the plant, the "planning engineer" password is deactivated. This means that the password level is automatically set to "40" = "planning engineer".

9591.40 – 43 Enter password to set current level

Password level selection.

Once you have entered the password, the current password level is set according to the password. After a reset, the system always selects the highest level which is not password protected.

9591.20 - 23 Password for level 40 (set planning engineer)

The "planning engineer" password can only be written when the current password level of parameter 9591.50 (page 174) is ≥ 40 . This means that the "planning engineer" password can only be set if parameter 9591.50 *Password level* (page 174) is at least set to "planning engineer" using the password selection parameter 9591.40 (page 174).

The "planning engineer" password is deactivated by entering an empty field.

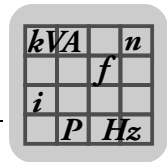

1.6.2 Output stage error response

Axis module

9729.1

Overtemperature response

Value range:

- 2 = Output stage inhibit / locked
- 3 = Stop at emergency stop limit / locked
- 5 = Output stage inhibit / waiting
- 6 = Stop at emergency stop limit / waiting
- 8 = Stop at application limit / waiting
- 9 = Stop at application limit / locked
- 10 = Stop at system limit / waiting
- 11 = Stop at system limit / locked

The overtemperature error of the axis will be triggered if parameter 9811.5 *Total -utilization* (page 9) exceeds 100%.

Overtemperature response of the axis module.

- **Output stage inhibit / locked**

The axis changes to controller inhibit state and activates the mechanical brake, if installed. If no brake is installed, the motor will coast to a halt. After a reset, the axis performs a system restart.

- **Stop at emergency stop limit / locked**

The motor is stopped along the emergency stop ramp. After a reset, the axis performs a system restart.

- **Output stage inhibit/waiting**

The axis changes to controller inhibit state and activates the mechanical brake, if installed. If no brake is installed, the motor will coast to a halt. After a restart, the axis performs a warm start. This means that the axis is immediately ready to operate again (without delay).

- **Stop at emergency stop limit / waiting**

The motor is stopped along the emergency stop ramp. After a restart, the axis performs a warm start. This means that the axis is immediately ready to operate again (without delay).

- **Stop at application limit/waiting**

The motor is stopped at the application limit. After a restart, the axis performs a warm start. This means that the axis is immediately ready to operate again (without delay).

- **Stop at application limit / locked**

The motor is stopped at the application limit. After a reset, the axis performs a system restart.

- **Stop at system limit/waiting**

The motor is stopped at the system limit. After a restart, the axis performs a warm start. This means that the axis is immediately ready to operate again (without delay).

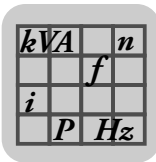

MX Parameter Description

Parameter description for unit functions

- **Stop at system limit / locked**

The motor is stopped at the system limit. After a reset, the axis performs a system restart.

For more information, refer to the operating instructions section "Operation and service".

Supply module

9729.2

Temperature
prewarning
response

Value range:

- 0 = No response
- 1 = Display only
- 2 = Output stage inhibit / locked
- 3 = Stop at emergency stop limit / locked
- 5 = Output stage inhibit / waiting
- 6 = Stop at emergency stop limit / waiting
- 8 = Stop at application limit / waiting
- 9 = Stop at application limit / locked
- 10 = Stop at system limit / waiting
- 11 = Stop at system limit / locked

Response temperature prewarning supply module.

The temperature prewarning error is triggered when the temperature of the supply module exceeds 85 °C.

The cut-off threshold is reached at 95 °C.

- **No response**

Error is ignored

- **Display only**

The 7-segment display shows the error but the axis does not respond (continues to operate).

- **Output stage inhibit / locked**

The axis changes to controller inhibit state and activates the mechanical brake, if installed. If no brake is installed, the motor will coast to a halt. After a reset, the axis performs a system restart.

- **Stop at emergency stop limit / locked**

The motor is stopped along the emergency stop ramp. After a reset, the axis performs a system restart.

- **Output stage inhibit/waiting**

The axis changes to controller inhibit state and activates the mechanical brake, if installed. If no brake is installed, the motor will coast to a halt. After a restart, the axis performs a warm start. This means that the axis is immediately ready to operate again (without delay).

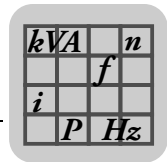

- **Stop at emergency stop limit / waiting**

The motor is stopped along the emergency stop ramp. After a restart, the axis performs a warm start. This means that the axis is immediately ready to operate again (without delay).

- **Stop at application limit/waiting**

The motor is stopped at the application limit. After a restart, the axis performs a warm start. This means that the axis is immediately ready to operate again (without delay).

- **Stop at application limit / locked**

The motor is stopped at the application limit. After a reset, the axis performs a system restart.

- **Stop at system limit/waiting**

The motor is stopped at the system limit. After a restart, the axis performs a warm start. This means that the axis is immediately ready to operate again (without delay).

- **Stop at system limit / locked**

The motor is stopped at the system limit. After a reset, the axis performs a system restart.

For more information, refer to the operating instructions section "Operation and service".

9729.5 Response
I×t prewarning

Value range: See parameter 9729.2 *Temperature prewarning response* (page 176)

Response I×t prewarning supply module.

The prewarning level is reached when the "current DC link current" ×"time" equals 80% of the product "nominal DC link current" ×"time".

	INFORMATION
	The error threshold is reached when the "current DC link current" ×"time" equals 110% of the product "nominal DC link current" ×"time".

9729.12 Response
I×t prewarning
internal braking
resistor

Value range: See parameter 9729.9 *Response TF / TH / KTY message* (page 50).

Response to I×t prewarning of the integrated braking resistor (with 10 kW supply module).

9729.4 Response
mains phase
failure

Value range: See parameter 9729.9 *Response TF / TH / KTY message* (page 50)

Response to mains phase failure.

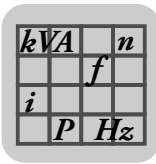

MX Parameter Description

Parameter description for unit functions

9746.1 Response mains OFF

Value range:

- 0 = DC link evaluation
- 1 = Mains control with controller inhibit
- 2 = Mains control and stop
- 3 = Mains control and application stop
- 4 = Mains control and system stop
- 5 = Mains control and emergency stop
- 6 = DC link control and no response
- 7 = Rapid mains control with output stage inhibit
- 8 = Rapid mains control with stop
- 9 = Rapid mains control with application stop
- 10 = Rapid mains control and system stop
- 11 = Rapid mains control and emergency stop
- 12 = Rapid mains control and internal response

Mains OFF response.

General definition of terms:

DC link control (ignore supply system failures):

See error response "0 = DC link evaluation" and "6 = DC link control and no response"

'Normal' mains control:

The 9702.1 Bit 30 "Power on" signal of the supply module is set when the DC link voltage is 240 V for the duration of 200 ms.

The 9702.1 Bit 30 "Power on" signal of the supply module is deleted when 2 half waves of the mains supply are absent. This will cause a delay of > 10 ms.

Rapid mains control:

As the DC link will loose nearly the entire load within milliseconds in the event of supply system disconnection and full motor load, you have the option to use rapid mains control.

Rapid mains control directly refers to the threshold parameter "9973.1 Mains off limit value" (page 180). The set response will be triggered immediately if the value falls below this limit. The response will take effect within 0.5 ms. The status bit 9702.1 Bit 30 "Power on" is set to "FALSE" within 0.5 ms.

This function enables power-off responses that are gentle on the mechanical components. This is realized by switching motors to regenerative operation very quickly. The energy generated by the motors then backs up the DC link, which causes an electrical deceleration ramp.

The brake is only applied when the actual speed is close to zero (bit "Motor at stand-still"). It is also monitored whether the drive truly decelerates. If not, the brake is applied immediately.

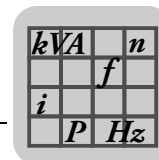

- **0 = DC link evaluation**

If the DC link voltage drops below the limit value 80 V and the unit is in "Power_on" state, the DC link voltage will be averaged during 100 ms.

If the averaged DC link voltage reaches the limit value of 240 V after expiry of 100 ms, the status will revert to 9702.1 Bit 30 "Power on". A system failure is compensated in this way.

If the averaged DC link voltage drops below the limit value of 240 V after expiry of 100 ms, the state will change to "Power_off".

The ready signal changes to "not ready" when the 9702.1 Bit 30 "Power on" signal of the supply module is not present any longer and the "Power_off" state is detected.

The output stage is also inhibited as response to Power_off.

- **1 = Mains control with controller inhibit**

Once the 9702.1 Bit 30 "Power on" signal of the supply module disappears, the brake is applied and the output stage is inhibited immediately. The ready signal changes to "not ready".

- **2 = Mains control and stop**

When the 9702.1 Bit 30 "Power on" signal disappears, the drive is stopped immediately at the set normal limits for torque and deceleration of the active FCB. The ready signal is removed when the drive has come to a stop.

If the 9702.1 Bit 30 "Power on" signal appears again while the drive decelerates to a stop, the stopping process will not be continued. The drive remains in "READY" state and the current FCB will be active again.

- **3 = Mains control and application stop**

When the 9702.1 Bit 30 "Power on" signal disappears, the drive is stopped immediately at the set application limits for torque and deceleration. The ready signal is removed when the drive has come to a stop.

If the 9702.1 Bit 30 "Power on" signal appears again while the drive decelerates to a stop, the stopping process will not be continued. The drive remains in "READY" state and the current FCB will be active again.

- **4 = Mains control and system stop**

When the 9702.1 Bit 30 "Power on" signal disappears, the drive is stopped immediately at the set system limits for torque and deceleration. The ready signal is removed when the drive has come to a stop.

If the 9702.1 Bit 30 "Power on" signal appears again while the drive decelerates to a stop, the stopping process will not be continued. The drive remains in "READY" state and the current FCB will be active again.

- **5 = Mains control and emergency stop**

When the 9702.1 Bit 30 "Power on" signal disappears, the drive is stopped immediately with the set emergency stop ramp for torque and deceleration. The ready signal is removed when the drive has come to a stop.

If the 9702.1 Bit 30 "Power on" signal appears again while the drive decelerates to a stop, the stopping process will not be continued. The drive remains in "READY" state and the current FCB will be active again.

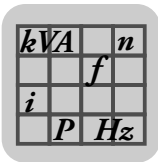

MX Parameter Description

Parameter description for unit functions

- **6 = DC link control and no response**

The DC link voltage is monitored as described under "0 = DC link evaluation". However, the level 80 V is not used for mains off detection but a level of 20 V. The monitoring type can be used when the mains off detection is to occur for a DC link that is almost empty.

- **7 = Rapid mains control with output stage inhibit**

The output stage is inhibited immediately if the DC link voltage falls below the value set in parameter *9973.1 Adjustable power off limit value* (page 180).

- **8 = Rapid mains control and stop**

If the DC link voltage falls below the value set in *parameter "9973.1 Adjustable power off limit value"* (page 180), the drive will be stopped immediately using the limit set for torque and deceleration of the active FCB. The ready signal is removed when the drive has come to a stop.

- **9 = Rapid mains control and application stop**

If the DC link voltage falls below the value set in *parameter "9973.1 Adjustable power off limit value"* (page 180), the drive will be stopped immediately using the set application limit. The ready signal is removed when the drive has come to a stop.

- **10 = Rapid mains control and system stop**

If the DC link voltage falls below the value set in parameter *9973.1 Adjustable power off limit value* (page 180), the drive will be stopped immediately using the set system limit. The ready signal is removed when the drive has come to a stop.

- **11 = Rapid mains control and emergency stop**

If the DC link voltage falls below the value set in parameter *9973.1 Adjustable power off limit value* (page 180), the drive will be stopped immediately using the deceleration set for emergency stop. The ready signal is removed when the drive has come to a stop.

- **12 = Rapid mains control and internal response**

If the DC link voltage falls below the parameter *9973.1 Adjustable power off limit value* (page 180), there will be no direct response. The status bit *9702.1 Bit 30 "Power on"* must be evaluated by a higher-level controller (note bus run times).

9973.1 Power off limit value "U_z threshold for rapid mains control"

Resolution: 10⁻³.

Value range: 0 – 450 – 2048.

Rapid mains control is triggered at the set value.

See response parameter *9746.1 Power off* (page 178).

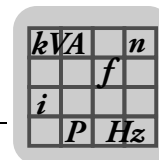

1.6.3 Reset behavior

8617.0 Manual
reset

Value range:

- 0 = No
- 1 = Yes

The current error is acknowledged when manual reset is set to Yes.

The error response of this current error defines the response to be triggered after a reset.

The error response can be "warm start", "system restart" and "CPU reset". For a detailed description of these responses, refer to the operating instructions.

Automatically reset to "No" after performing reset (by setting to "Yes").

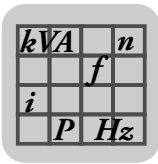

2 MXR Parameter Description

2.1 Parameter description for display values

2.1.1 Process values output stage

8325.0 DC link voltage	Unit: V Current value of the DC link voltage V_{DC}
9786.1 Output current	Unit: % Current value of the output current of MXR in relation to the rated device current.
8326.0 Filtered output current	Unit: A Current filtered value of the output current.
10467.40 Effective power	Unit: kW Current active power of the MXR supply and regenerative module; negative values specify the regenerative power that is fed back into the supply system. Positive values specify the active power input from the supply system.
10467.42 Filtered effective power	Unit: kW Current filtered power of the MXR supply and regenerative module; negative values specify the regenerative power that is fed back into the supply system. Positive values specify the active power input from the supply system.
10467.41 Regenerated energy	Unit: kWh Displays the amount of energy regenerated since the last reset. The last parameter value will be stored in a non-volatile memory. The parameter can be reset by writing the value "0" to it. In the parameter tree of MotionStudio, the value is displayed with the resolution [kWh]. If the value is read directly from the unit, e.g. via fieldbus, the resolution is [Wh].
10467.14 U_d setpoint	Unit: V Active voltage setpoint

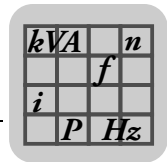

<i>10467.15 Uq setpoint</i>	Unit: V Reactive voltage setpoint
<i>10467.8 Id setpoint</i>	Unit: A Active current setpoint
<i>10467.9 Iq setpoint</i>	Unit: A Reactive current setpoint
<i>9859.1 Thermal current limit</i>	Unit: % Displays the actual thermal current limit in % of the MXR supply and regenerative module. The MXR module has a brief overload capacity up to this maximum limit (maximum operating point). The thermal current limit is dynamically adjusted according to the utilization of MXR. It starts at 250% and becomes smaller depending on utilization.
<i>9811.5 Total utilization</i>	Unit: % Current unit utilization in % of the rated unit power.
<i>9811.1 Dynamic utilization chip rise</i>	Unit: % Dynamic utilization of the chip hub in percent (Ixt utilization). The parameter is unfiltered.
<i>9811.4 Heat sink utilization</i>	Unit: % Current heat sink utilization.
<i>9795.1 Heat sink temperature</i>	Unit: °C Current heat sink temperature.
<i>9811.3 Electromechanical utilization</i>	Unit: % Current electromechanical utilization.

2.1.2 Unit status

In the "Unit status" parameter group, you can read out all information about the current unit state.

2.1.3 Unit data

In the "Unit data" parameter group, you can read out all information about the unit variant and option cards. The unit status and the version number of the firmware are displayed here.

2.1.4 Unit nameplate

In the "Unit nameplate" parameter group, you can read out information such as the serial number and status information of the hardware and software of MXR and the option subassembly.

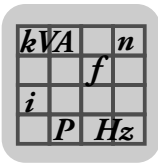

MXR Parameter Description

Parameter description of system data

2.1.5 Error history

The error history consists of 6 error ring memories, in which the most recent errors are stored. In addition, each error ring memory saves process values and the states of the binary inputs and outputs at the time of the error.

2.1.6 Line process values

10467.16 U_{alpha}	Unit: V Real part of voltage phasor.
10467.17 U_{beta}	Unit: V Imaginary part of voltage phasor.
10467.3 I_{alpha}	Unit: A Real part of current phasor.
10467.4 I_{beta}	Unit: A Imaginary part of current phasor.
10467.12 U_d	Unit: V Active voltage
10467.13 U_q	Unit: V Reactive voltage
10467.50 I_d	Unit: A Active current
10467.51 I_q	Unit: A Reactive current

2.2 Parameter description of system data

2.2.1 Startup

10470.10 Line frequency	Unit: Hz Value range: <u>50</u> Hz, 60 Hz This parameter can be used to set the line frequency of the supply system.
10470.14 Line voltage	Unit: V Value range: 380 – <u>400</u> – 480 This parameter can be used to set the line voltage of the supply system.

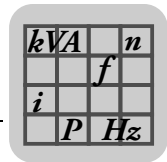

10470.2 PWM frequency

Unit: kHz

Value range: 50 kW: 8 kHz, 75 kW: 4 kHz

The parameter sets the PWM frequency [kHz] for the MXR supply and regenerative module. The parameter must be set depending on the projected unit power of 50 or 75 kW:

50 kW: 8 kHz

75 kW: 4 kHz

Due to the upstream choke and the line filter, the PWM frequency cannot be selected freely, but is determined by the design.

See also page 41 and subsequent pages.

To change the PWM frequency, it is necessary to replace these upstream units and in some cases to adapt the installed cable cross sections, the fuses and the line contactor.

10469.4 Mains OFF tolerance

Unit: ms

Value range: 0 – 20000

The mains off tolerance can be used to set the time after which an error is triggered in the event of a line voltage failure.

Note that during regenerative operation an error can be triggered before the set mains off tolerance time has elapsed if the DC link capacitors are fully charged, no more regenerative power can be absorbed, and no optional braking resistor is connected.

10472.11 Timeout when opening the line contactor

Unit: ms

Value range: 0 – 1000

Monitors the time after the enable signal is revoked until the "Line contactor feedback" signal is no longer pending. When the monitoring time set here is exceeded, an error is triggered.

10472.1 Timeout monitoring of charging process

Unit: ms

Value range: On/off

After the enable signal is issued, this function monitors whether the DC link voltage reaches 300 V within the timeout interval of 10 s. The function also monitors whether the DC link voltage reaches the setpoint value within a timeout interval of 5 s after the controller has been enabled.

2.2.2 Controller parameters

9813.1 Activate I_xt current reduction

Unit:

Value range: On/off

A current limit is set using the parameter setting "On/off" to ensure reliable operation of the axes even in the case of an overload.

The switch is only implemented in "Controller inhibit active" status.

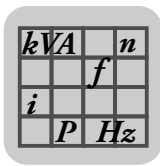

MXR Parameter Description

Communication parameter description

10467.2 V_{DC} link
setpoint

Unit: V

This parameter shows the setpoint for the controlled DC link voltage.

2.2.3 Basic settings

See "MOVIAXIS® Multi-Axis Servo Inverter" system manual, chapter "Description of communication parameters"

2.3 Communication parameter description

2.3.1 Control word CAN1 / CAN2 / communication options

9514.1 CAN1 /
9515.1 CAN2 /
9516.1

Value range: None/CAN1

Here, you can set the source of the control word information.

Communication
option data source

9514.3 CAN1 /
9515.3 CAN2 /
9516.3

See "MOVIAXIS® Multi-Axis Servo Inverter" system manual, parameter 9514.3

Communication
option data block
start

9514.4 CAN1 /
9515.4 CAN2 /
9516.4

Unit: Number of words

Value range: 0 – 4 – 16

This parameter can be used to set the length of the data block.

Communication
option data block
length

9514.19 CAN1 /
9515.19 CAN2 /
9516.19

Unit: ms

Value range: 0 – 20 – 10000

Here, you can set the monitoring time after which an error is triggered if no telegrams are received any longer. The setting 0 deactivates the monitoring function.

Communication
option timeout
interval

9514.5 CAN1 /
9515.5 CAN2 /
9516.5

See "MOVIAXIS® Multi-Axis Servo Inverter" system manual, parameter 9514.5

Communication
option update

9514.16 CAN1 /
9515.16 CAN2 /
9516.16 Communi-
cation option
configuration error

See "MOVIAXIS® Multi-Axis Servo Inverter" system manual, parameter 9514.16

9514.2 CAN1 /
9515.2 CAN2
message ID

Here, you can set the ID of the received CAN message.

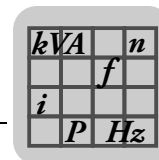

9514.14 CAN1 /
9515.14 CAN2
data acceptance
with sync

Here, you can set whether the data is accepted with a sync message.

9514.14 CAN1 /
9515.14 CAN2
nEndianness

Value range: Big endian (Motorola format) / little endian (Intel format)
Indicates the data format set for the CAN messages.

2.3.2 Status word CAN1 / CAN2 / communication options

9563.3 CAN1 /
9564.3 CAN2 /
9565.3
Communication
option data sink

Value range: None/CAN1 system bus
This parameter determines the communication channel used for transmitting status information.

9563.5 CAN1 /
9564.5 CAN2 /
9565.5 Communi-
cation option data
block start

See "MOVIAXIS® Multi-Axis Servo Inverter" system manual, parameter 9563.5

9563.6 CAN1 /
9564.6 CAN2 /
9565.6 Communi-
cation option data
block length

Unit: Number of words
Value range: 0 – 4 – 16
This parameter can be used to set the length of the data block.

9563.16 CAN1 /
9564.16 CAN2 /
9565.16 Communi-
cation option
configuration error

Indicates a configuration error.

9563.4 CAN1 /
9564.4 CAN2
message ID

Shows the ID of the sent CAN message.

9563.1 CAN1 /
9564.1 CAN2
Send PDO after
sync

Indicates whether messages with status information are sent after the sync message.

9563.17 CAN1 /
9564.17 CAN2
Blocking time

See "MOVIAXIS® Multi-Axis Servo Inverter" system manual, parameter 9563.17

9563.21 CAN1 /
9564.21 CAN2
Endianness

Indicates the data format set for the CAN messages: Big endian (Motorola format) / little endian (Intel format).

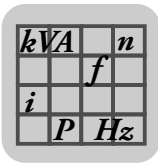

MXR Parameter Description

Communication parameter description

<p>9563.2 CAN1 / 9564.2 CAN2 Send PDO cyclically</p>	<p>Unit: ms</p> <p>Indicates the intervals for sending the process data objects (PDOs).</p>
<p>9563.22 CAN1 / 9564.22 CAN2 Send PDO after n sync</p>	<p>Indicates the number of sync messages after which PDOs are sent.</p>
<p>9563.23 CAN1 / 9564.23 CAN2 Send PDO following change</p>	<p>Indicates whether PDOs are only sent after the data to be sent has been changed.</p>
<p>9563.19 CAN1 / 9564.19 CAN2 Send PDO following receipt of IN-PDO</p>	<p>Indicates whether Out-PDOs are sent after PDOs have been received.</p>
<p>9856.2 CAN1 / 9856.3 CAN2 layout</p>	<p>Determines the layout to be used for the status word:</p> <p>Programmable layout:</p> <p>The assignment of the individual status bits is determined by the user.</p> <p>Progr. layout/error code:</p> <ul style="list-style-type: none"> • Bits 0 – 7 are determined by the user • Bits 8 – 15 transmit the error code
<p>8334.0 / 8334.1 / 8349.0 / 8349.1 / 9559.3 / 9559.4 I/O basic unit</p>	<p>The assignments and states of the binary inputs/outputs are displayed. The function of the binary outputs DO-2 and DO-3 can also be set. The assignment of the following inputs/outputs is fixed:</p> <ul style="list-style-type: none"> • DI-0: Output stage enable DI-1: Enable (Index 8334.0,0) • DI-3: Line contactor feedback (Index 8334.0,1) • DO-0: Ready for operation (Index 8349.0,0) • DO-1: Ready for power on (Index 8349.0,1) • DO-2: N. fct. (default) / function can be set by the user (Index 9559.3) • DO-3: N. fct. (default) / function can be set by the user (Index 9559.4)

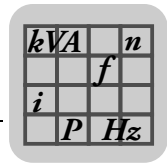

2.4 Parameter description for unit functions

2.4.1 Setup

See "MOVIAXIS® Multi-Axis Servo Inverter" system manual, chapter "Description of unit parameters".

2.4.2 Reset behavior

See "MOVIAXIS® Multi-Axis Servo Inverter" system manual, chapter "Description of unit parameters".



Index

0 ... 9

10046.11 / 10046.12 / 10046.13 Temperature sensor type	41
10052.1 Setpoint cycle lateral communication for position balancing	161
10052.10 Current lag error dual drive	163
10052.11 Torque limitation mode.....	163
10052.12 Torque limit 1 / 2 / 3 / 4 source.....	164
10052.13 Torque limit 1 local.....	164
10052.2 P-gain position balancing controller	161
10052.20 Positive transition speed	164
10052.21 Negative transition speed	164
10052.22 Positive transition mode.....	164
10052.23 Negative transition mode	164
10052.25 Threshold position adjustment	161
10052.26 Lag error window dual drive adjustment phase.....	161
10052.27 Maximum synchronizing speed.....	161
10052.28 FCB 22 Mode	162
10052.3 Velocity setpoint source	162
10052.30 FCB Position balancing source.....	163
10052.4 Local velocity setpoint.....	162
10052.5 Position balancing setpoint source.....	163
10052.7 Position difference	162
10052.8 Lag error response.....	163
10052.9 Lag error	163
10054.1 Measured encoder offset	152
10054.11 Preset offset.....	153
10054.2 Encoder adjustment write position	153
10054.3 Encoder adjustment status	152
10054.4 Write control encoder adjustment	152
10054.5 Measuring current	153
10054.6 Mode	147
10054.7 Write status	152
10056.1 / 10056.2 / 10056.3 Velocity threshold "Motor at standstill" - status bit.....	47
10057.1 / 10057.2 / 10057.3 Filter time "Motor at standstill" - status bit.....	47
10058.1 / 10058.2 / 10058.3 Switched integrator	33
10059.1 NMax source.....	36
10059.3 Source of maximum speed balancing controller remote axis 3.....	162
10060.1 NMin source.....	36
10060.1 Source of minimum speed balancing controller remote axis 1.....	162
10061.1 NMax local	36
10062.1 NMin local	36
10063.1 / 10063.2 / 10063.3 (not in parameter tree).....	48
10064.1 / 10064.2 / 10064.3 Software limit switch positive.....	46
10065.1 Select parameter set.....	172
10068.1 Actual position	119
10068.1 Position	5
10069.1 Model	19
10070.1 Model	20
10071.1 Suberror code	13
10072.1 Suberror	20
10118.1 Sync mode CAN1	77
10118.2 Sync mode CAN2	77
10120.1 Velocity	5, 155, 164, 172
10201.1 / 10201.2 / 10201.3 Setpoint limit position controller	35
10438.1 Measured encoder offset	170
10438.10 Write status.....	170
10438.3 Mode.....	166
10438.3 Wait time to write operation	170
10438.4 Write control.....	169
10444.1 / 10444.2 / 10444.3 Actual position	116
10445.1 Deceleration source	171
10445.2 Deceleration local	171
10445.3 Jerk source	171
10445.4 Local jerk	171
10445.5 Stop with position control.....	171
10445.6 Bit 0 stop with position control active.....	171
10467.12 Ud	184
10467.13 Uq	184
10467.14 Ud setpoint.....	182
10467.15 Uq setpoint.....	183
10467.16 Ualpha	184
10467.17 Ubeta	184
10467.2 DClk setpoint.....	186
10467.3 Ialpha	184
10467.4 Ibeta	184
10467.40 Effective power	182
10467.41 Regenerated energy	182
10467.42 Filtered effective power.....	182
10467.50 Id.....	184
10467.51 Iq.....	184
10467.8 Id setpoint	183
10467.9 Iq setpoint	183
10469.4 Mains OFF tolerance	185
10470.10 Line frequency	184
10470.14 Line voltage	184



10470.2 PWM frequency	185	9512.1 Source control word 0	83
10472.1 Timeout monitoring of charging process	185	9513.1 Layout	84
10472.11 Timeout when opening the line contactor	185	9513.10 Bit 0	85
8325.0 DC link voltage	8, 182	9513.11 Bit 1	87
8326.0 Filtered output current	182	9514.1 CAN1 / 9515.1 CAN2 / 9516.1 Communication option	186
8326.0 Output current	8	9514.1 Data source	81
8334.0 Actual value digital inputs	104	9514.14 CAN1 / 9515.14 CAN2 data acceptance with sync	187
8334.0 / 8334.1 / 8349.0 / 8349.1 / 9559.3 / 9559.4 I/O basic unit	188	9514.14 CAN1 / 9515.14 CAN2 nEndianness	187
8349.0 Actual value digital outputs	104	9514.14 Data acceptance with sync	82
8453.0 Fieldbus baud rate	79	9514.16 CAN1 / 9515.16 CAN2 / 9516.16 Communication option	186
8454.0 Fieldbus address	79	9514.16 Configuration error	81
8537.0 Direction of rotation reversal	23	9514.17 PDO ID	82
8557.0 Speed monitoring	41	9514.18 Address sender IN buffer 0	82
8558.0 / 8560.0 / 9722.3 Speed monitoring delay time	42	9514.19 CAN1 / 9515.19 CAN2 / 9516.19 Communications option	186
8584.0 / 8586.0 / 8587.0 Brake function	43	9514.19 Timeout interval	81
8585.0 / 8586.0 / 8587.0 Brake application time	41	9514.2 CAN1 / 9515.2 CAN2 message ID	186
8596.0 Reset statistics data	173	9514.2 Message ID	82
8600.0 CAN1 address	76	9514.20 Endianness IN buffer 0	82
8603.0 CAN1 baud rate	76	9514.3 CAN1 / 9515.3 CAN2 / 9516.3 Communication option	186
8606.0 Timeout	79	9514.3 Data block start	81
8617.0 Manual reset	13, 181	9514.4 CAN1 / 9515.4 CAN2 / 9516.4 Communication option	186
8749.0 / 8750.0 / 9745.3 Brake release time	40	9514.4 data block length	81
8904.0 / 8905.0 / 10046.1 (not in parameter tree)	48	9514.5 CAN1 / 9515.5 CAN2 / 9516.5 Communication option	186
8932.0 CAN2 address	76	9514.5 Update	81
8937.0 CAN1 protocol selection	76	9530.1 Access channel 0 32-bit	89
8938.0 CAN2 protocol selection	76	9530.2 - 16 Access channel 1 - 15 32-bit	90
8939.0 CAN2 baud rate	76	9531.1 System unit channel 0	90
9500.6 Actual speed	20	9531.2 - 16 System variable channel 1 - 15	90
9501.50 Velocity	19	9532.1 - 9532.4 Velocity unit text	55
9501.51 Velocity	19	9535.1 Velocity resolution	55
9501.52 Velocity	19	9536.1 Velocity numerator	56
9501.53 Velocity	19	9537.1 Velocity denominator	56
9502.1 Resolution	18	9538.1 KTY	19
9503.1 Numerator	19	9539.1 - 9539.4 Position unit text	54
9503.10 Denominator	19	9542.1 Position resolution	55
9504.1 Frequency	22	9543.1 Position numerator	55
9505.1 Output voltage	20	9544.1 Position denominator	55
9506.6 Actual position	21	9545.1 KTY	20
9507.50 Position	18	9546.1 - 9546.4 Acceleration unit text	56
9508.1 Resolution	18	9549.1 Acceleration resolution	56
9509.1 Numerator	18	9550.1 Acceleration numerator	56
9509.10 Denominator	18	9551.1 Acceleration denominator	56
9510.1 Actual value source	83, 87	9552.1 - 9552.4 Torque unit text	57
9511.1 Actual value	91		



9555.1 Torque resolution	57	9571.1 Maximum acceleration	52
9556.1 Torque numerator	57	9572.1 Maximum deceleration	52
9557.1 Torque denominator	58	9573.1 Maximum acceleration	51
9558.1 / 9558.2 / 9558.3 Current limit	31	9574.1 Maximum deceleration	51
9559.1 Bit 0	92	9576.1 Emergency stop deceleration	52
9559.2 - 16 Bit 1 - 15	97	9579.1 Maximum positive velocity	51
9560.1 System unit channel 0	98	9579.10 Maximum negative velocity	51
9560.2 - 9560.16 System variable channel 1 - 15	99	9580.1 Maximum torque	51
9561.1 Actual value high word channel 0	99	9582.1 Maximum jerk	53
9561.2 - 9561.16 Actual value high word channel 1 - 15	99	9583.1 Maximum jerk	52
9562.1 Actual value low word channel 0	99	9585.1 Source	104
9562.2 - 9562.16 Actual value low word channel 1 - 15	99	9591.20 - 23 Password for level 40 (set planning engineer)	174
9563.1 CAN1 / 9564.1 CAN2 Send PDO after sync	187	9591.40 - 43 Enter password to set current level	174
9563.1 Send PDO after sync	101	9591.50 Current password level	174
9563.16 CAN1 / 9564.16 CAN2 / 9565.16 Communication option configuration error	187	9593.1 / 9593.2 / 9593.3 Numerator factor	113
9563.16 Config error	100	9593.10 / 9593.11 / 9593.12 Denominator factor	113
9563.17 Blocking time	101	9594.1 Modulo underflow	54
9563.17 CAN1 / 9564.17 CAN2 Blocking time	187	9594.10 Modulo overflow	53
9563.18 PDO ID	102	9595.1 / 9595.2 / 9595.3 Connected to drive no	116
9563.19 CAN1 / 9564.19 CAN2 Send PDO following receipt of IN-PDO	188	9596.1 / 9596.2 / 9596.3 Referenced (encoder status bit 7)	115
9563.19 Send PDO following change of IN buffer	102	9597.1 / 9597.2 / 9597.3 Actual speed source	38, 117
9563.2 CAN1 / 9564.2 CAN2 Send PDO cyclically	188	9598.1 Velocity setpoint source	123
9563.2 Send PDO cyclically	101	9598.10 Local jerk setpoint	124
9563.21 CAN1 / 9564.21 CAN2 Endianess	187	9598.2 Local velocity setpoint	123
9563.21 Endianess	101	9598.3 Torque limit source	123
9563.22 CAN1 / 9564.22 CAN2 Send PDO after n sync	188	9598.4 Local setpoint torque limit	123
9563.22 Send PDO after n syncs	101	9598.5 Acceleration source	124
9563.23 CAN1 / 9564.23 CAN2 Send PDO following change	188	9598.6 Local acceleration setpoint	124
9563.23 Send PDO following change	102	9598.7 Deceleration source	124
9563.24 Transmission cycle	103	9598.8 Local deceleration setpoint	124
9563.3 CAN1 / 9564.3 CAN2 / 9565.3 Communication option data sink	187	9598.9 Jerk source	124
9563.3 Data sink OUT buffer 0	100	9599.1 Torque setpoint source	131
9563.4 CAN1 / 9564.4 CAN2 message ID	187	9599.2 Local torque setpoint	131
9563.4 Message ID	101	9599.3 Source velocity limit	131
9563.5 CAN1 / 9564.5 CAN2 / 9565.5 Communication option data block start	187	9599.4 Local velocity limit	132
9563.5 Data block start	100	9599.5 Jerk source	132
9563.6 CAN1 / 9564.6 CAN2 / 9565.6 Communication option data block length	187	9599.6 Local jerk	132
9563.6 data block length	100	9600.1 Test	156
		9600.2 Test torque source	157
		9600.3 Local test torque	157
		9600.4 Speed setpoint source	157
		9600.5 Local speed setpoint	157
		9600.6 Test duration	158
		9600.7 Error response	157



9600.8 Status.....	157	9625.1 I/O PDO 2 slot.....	107
9600.9 Protocol torque.....	158	9625.111 PDO source.....	107
9603.1 PDO timeout response.....	74	9625.121 AO1 low word source.....	108
9604.1 Positive speed setpoint.....	153, 154	9625.122 AO1 high word source.....	108
9604.17 Lag error window.....	155	9625.123 AO1 value source 32 bit.....	108
9604.18 Jog lag error response.....	155	9625.124 AO1 scaling to V numerator.....	108
9604.2 Negative speed setpoint.....	154	9625.125 AO1 scaling to V denominator.....	109
9604.5 Acceleration.....	154	9625.126 AO1 offset.....	109
9604.6 Deceleration.....	154	9625.127 AO1 output voltage.....	109
9604.7 Jerk.....	154	9625.132 AO2 high word source.....	108
9605.1 / 9605.2 / 9605.3 Maximum speed.....	37	9625.133 AO2 value source 32 bit.....	108
9606.1 / 9606.2 / 9606.3 Nominal flow.....	37	9625.134 AO2 scaling to V numerator.....	108
9609.1 / 9609.2 / 9609.3 Nominal current I _q	37	9625.135 AO2 scaling to V denominator.....	109
9610.1 / 9610.2 / 9610.3 Nominal torque.....	37	9625.136 AO2 offset.....	109
9617.1 Maximum possible output speed.....	14	9625.137 AO2 output voltage.....	109
9617.2 Maximum output current.....	14	9625.21 AI1 input voltage.....	107
9617.6 Nominal unit current.....	14	9625.22 AI1 offset.....	107
9619.1 I/O PDO 1 slot.....	104	9625.23 AI1 scaling numerator.....	107
9619.111 PDO source.....	104	9625.24 AI1 scaling denominator.....	107
9619.121 AO1 low word source.....	106	9625.25 AI1 scaled value 32 bit.....	108
9619.122 AO1 high word source.....	106	9625.26 AI1 scaled value low word.....	108
9619.123 AO1 value source 32 bit.....	106	9625.27 AI1 scaled value high word.....	108
9619.124 AO1 scaling to V numerator.....	106	9625.31 AI2 input voltage.....	107
9619.125 AO1 scaling to V denominator.....	106	9625.32 AI2 offset.....	107
9619.126 AO1 offset.....	106	9625.33 AI2 scaling numerator.....	107
9619.127 AO1 output voltage.....	106	9625.34 AI2 scaling denominator.....	108
9619.131 AO2 low word source.....	106	9625.35 AI2 scaled value 32 bit.....	108
9619.132 AO2 high word source.....	106	9625.36 AI2 scaled value low word.....	108
9619.133 AO2 value source 32 bit.....	106	9625.37 AI2 scaled value high word.....	108
9619.134 AO2 scaling to V numerator.....	106	9626.1 Error memory pointer.....	18
9619.135 AO2 scaling to V denominator.....	106	9627.1 Error.....	20
9619.136 AO2 offset.....	106	9628.1 Inputs.....	18
9619.137 AO2 output voltage.....	107	9629.1 Inputs.....	18
9619.21 AI0 input voltage.....	105	9629.2 Inputs.....	18
9619.22 AI0 offset.....	105	9630.1 Outputs.....	18
9619.23 AI0 scaling numerator.....	105	9631.1 Outputs.....	18
9619.24 AI1 scaling denominator.....	105	9631.2 Outputs.....	18
9619.25 AI1 scaled value 32 bit.....	105	9632.1 Device status.....	21
9619.26 AI1 scaled value low word.....	105	9633.1 Output current.....	21
9619.27 AI1 scaled value high word.....	105	9634.1 Active current.....	22
9619.31 AI1 input voltage.....	105	9635.1 Device.....	20
9619.32 AI1 offset.....	105	9636.1 DC link voltage.....	20
9619.33 AI1 scaling numerator.....	105	9654.1 Acceleration reference travel.....	72
9619.34 AI2 scaling denominator.....	105	9654.2 Deceleration reference travel.....	73
9619.36 AI2 scaled value low word.....	105	9654.3 Jerk reference travel.....	73
9619.37 AI2 scaled value high word.....	105	9654.4 Torque reference travel.....	73
9622.1 Heat exchanger.....	19	9655.1 Reference dwell time fixed stop.....	73
9623.1 Abs.....	19	9656.1 Travel to start position.....	71
9624.1 Thermal.....	20	9657.1 HW limit switch for velocity changeover.....	72



9658.2 Reference travel type	59	9702.5 Error code	13
9701.1 - 5 Axis type	14	9702.6 Current FCB instance	11, 120
9701.10 Unit series	14	9703.1 Velocity	124, 131, 144
9701.11 Unit variant	14	9704.1 Position	5, 141, 143, 144, 155, 172
9701.110 Status 1	17	9704.2 / 9704.3 / 9704.4 Actual position	116, 117
9701.111 Status 2	17	9705.1 / 9705.2 / 9705.3 KTY sensor motor utilization	49
9701.113 Status 4	17	9706.1 Output voltage	8
9701.114 Status 5	17	9716.1 Maximum positive velocity	52
9701.115 Status 6	17	9716.10 Maximum negative velocity	53
9701.116 Status 7	17	9718.1 / 9718.2 / 9718.3 Speed monitoring reset time factor	42
9701.117 Status 8	17	9719.1 / 9719.2 / 9719.3 Counting direction	111
9701.118 Status 9	17	9727.3 Delivery state "d1"	173
9701.125 Option 1 software status	17	9727.4 Factory setting "d2"	173
9701.126 Option 1 hardware status	17	9729.1 Overtemperature response	175
9701.13 Nominal unit voltage	14	9729.12 Response lxt prewarning internal braking resistor	177
9701.135 Option 2 software status	17	9729.13 / 9729.14 / 9729.15 Software limit switch response	46
9701.136 Option 2 hardware status	17	9729.16 Response to external error	75
9701.14 Number of input phases	14	9729.17 Fieldbus timeout response	79
9701.145 Option 3 software status	17	9729.18 Response to positioning lag error ..	137, 143
9701.146 Option 3 hardware status	17	9729.2 Temperature prewarning response	176
9701.15 Radio interference suppression on mains end	14	9729.4 Response mains phase failure	177
9701.155 Option 4 software status	17	9729.5 Response lxt prewarning	177
9701.156 Option 4 hardware status	17	9729.6 / 9729.7 / 9729.8 Hardware limit switch response	45
9701.165 Option 5 software status	17	9729.9 TF / TH / KTY signal response	50
9701.166 Option 5 hardware status	17	9730.1 Reference offset	72
9701.17 Standard encoder system	14	9730.2 Start position	72
9701.18 Device serial number	14	9730.3 Reference offset modulo	72
9701.30 Firmware part number basic unit	15	9731.1 Start position velocity reference speed 3 ...	72
9701.31 Firmware status basic unit	15	9731.2 Clear velocity reference speed 2	72
9701.32 Firmware version number basic unit	15	9731.3 Search velocity reference speed 1	72
9701.33 DSP firmware part number	15	9732.1 / 9732.2 / 9732.3 Number of pole pairs	36
9701.34 DSP firmware status	15	9733.1 / 9733.2 / 9733.3 Encoder type	110
9701.35 DSP firmware version number	15	9734.1 LI controller	31
9701.37 FPGA status	15	9737.1 / 9737.2 / 9737.3 Flow time constant ...	37, 38
9701.41 Signal electronics	16	9738.1 / 9738.2 / 9738.3 Rotor resistance	37
9701.50 Option in slot 1	16	9740.4 Maximum torque	53
9701.53 Option in slot 1, firmware part number	16	9744.1 / 9744.2 / 9744.3 Actual position source ...	38, 117
9701.54 Option in slot 1, firmware status	16	9746.1 Response mains OFF	178
9701.60 Option in slot 2	16	9748.1 / 9748.2 / 9748.3 PWM frequency	25
9701.63 Option in slot 2, firmware part number	16	9749.11 / 9749.12 / 9749.13 Encoding monitoring ...	112
9701.64 Option in slot 2, firmware status	16	9750.1 Referencing to zero pulse	71
9701.70 Option in slot 3	16	9751.11 / 9751.12 / 9751.13 Machine zero offset	116
9701.73 Option in slot 3, firmware part number	16		
9701.74 Option in slot 3, firmware status	16		
9702.1 Status display	11		
9702.2 Axis status	11		
9702.3 Current FCB	11, 120		
9702.4 Active parameter set	11, 172		



9754.1 - 16 data word 0 - 15	83	9834.1 / 2 / 3 Encoder offset P1 – P3	170
9770.1 Data source word 0	103	9834.1 / 9834.2 / 9834.3 Encoder offset	38
9770.2 - 9770.16 Data source word 1 - 15	103	9835.1 Time interval between sync signals	80
9782.1 / 9782.2 / 9782.3 Encoder identification	116	9836.1 Synchronization source	80
9784.1 Torque	6	9838.1 Acceleration precontrol filter	33
9786.1 Output current	7, 182	9839.1 Modulo position	5, 142, 144, 155
9787.1 Torque current	7	9839.1 Position modulo	142, 144
9788.1 Magnetization current	7	9839.2 / 9839.3 / 9839.4 Actual position modulo	117
9791.1 Torque voltage	8	9841.1 / 9841.2 / 9841.3 Speed setpoint filter	33
9792.1 Magnetization voltage	8	9842.1 Actual speed value filter	33
9793.1 Output frequency	7	9843.1 / 9843.2 / 9843.3 P-gain	35
9795.1 Heat sink temperature	9, 183	9844.1 Local value	91
9797.1 / 9797.2 / 9797.3 P-gain	32	9851.1 Source	91
9798.1 / 9798.2 / 9798.3 Monitor software limit switch negative	46	9852.1 Phase failure detection	21
9800.1 Thermal motor model temperature	49	9853.1 Torque current	8
9801.1 / 9801.2 / 9801.3 Monitor software limit switch positive	46	9855.1 Magnetization current	8
9803.1 Local value	84	9856.1 Layout	92
9804.1 Select FCB with instance	120	9856.2 CAN1 / 9856.3 CAN2 Layout	188
9806.1 / 9806.2 / 9806.3 Acceleration precontrol gain	33	9857.1 Reference travel status	144
9811.1 Dynamic utilization chip rise	9, 183	9859.1 Thermal current limit	8, 183
9811.2 Dynamic utilization chip absolute	9	9861.1 / 9861.2 / 9861.3 Maximum torque	37
9811.3 Electromechanical utilization	10, 183	9864.1 - 9864.16 Actual value word 0 - 15	103
9811.4 Heat sink utilization	9, 183	9872.1 / 9872.2 / 9872.3 Temperature KTY sensor	48
9811.5 Total utilization	9, 183	9872.255 KTY temperature motor	6
9812.1 Rel.	19	9873.1 Active factory setting	11, 173
9813.1 Activate lxt current reduction	24	9874.1 Thermal motor model motor utilization	49
9813.1 Activate lxt current reduction	185	9874.255 Motor utilization, maximum KTY model	7
9816.1 / 9816.2 / 9816.3 Rotor time constant	38	9876.1 Actual value channel 0	90
9817.1 Total mass moment of inertia	35	9876.2 - 16 Actual value	90
9818.34 / 9818.24 / 9818.20 Encoder part number/encoder name	110	9877.1 Sync period CAN1	77
9819.1 / 9819.2 / 9819.3 Nominal current Id	37	9877.2 Sync offset CAN1	78
9820.1 / 9820.2 / 9820.3 Motor type	36	9877.3 Sync start mode CAN1	78
9821.1 / 9821.2 / 9821.3 Scanning frequency	32	9877.5 Setpoint cycle CAN1	77
9822.1 Source process data channel 0	89	9878.1 Sync period CAN2	77
9822.2 - 16 Source process data channel 1	90	9878.2 Sync offset CAN2	78
9823.1 - 5 Unit signature	15	9878.3 Sync start mode CAN2	79
9824.1 / 9824.2 / 9824.3 Software limit switch monitoring source	46	9878.5 Setpoint cycle CAN2	77
9825.1 Scope ID CAN1	76	9879.1 Sync period gateway	80
9826.1 / 9826.2 / 9826.3 Voltage limit	31	9879.2 Sync offset gateway	80
9828.2 / 9828.3 Numerator emulation	114	9879.3 Sync start mode gateway	80
9829.2 / 9829.3 Denominator emulation	114	9880.3 Initial boot loader part number	15
9831.1 Stop process data	73	9880.5 Initial boot loader status	15
9833.1 / 9833.2 / 9833.3 Brake type	40	9881.3 Boot loader part number	15
9834 Encoder offset P1 - P3	153	9881.5 Boot loader status	15
		9882.1 Synchronization ID CAN2	76
		9883.1 Synchronization ID CAN1	76



9885.1 Use control bit "feed enable"	135	9965.11 Abs. local torque limit Q3	128
9885.2 Control bit "Accept position"	135	9965.12 Abs. source torque limit Q4	128
9885.3 In Position window	136	9965.13 Abs. local torque limit Q4	128
9885.4 In Position hysteresis	136	9965.14 Positive transition speed	130
9885.5 Positioning lag error window	137	9965.15 Negative transition speed	131
9886.1 - 9949.1 Operating mode	138	9965.16 Positive transition mode	129
9886.10 - 9949.10 Jerk source	141	9965.17 Negative transition mode	130
9886.11 - 9949.11 Local jerk	141	9965.2 Local speed setpoint	125
9886.12 - 9949.12 Max. positioning velocity negative source	140	9965.5 Torque limit mode	126
9886.13 - 9949.13 Local max. positioning velocity negative	140	9965.6 Abs. source torque limit Q1	127
9886.2 - 9949.2 Positioning setpoint source	139	9965.7 Abs. local torque limit Q1	127
9886.3 - 9949.3 Local positioning setpoint	140	9965.8 Abs. source torque limit Q2	127
9886.4 - 9949.4 Max. positioning velocity positive source	140	9965.9 Abs. local torque limit Q2	128
9886.5 - 9949.5 Local max. positioning velocity positive	140	9966.1 Setpoint position source	143
9886.6 - 9949.6 Max. acceleration source	140	9966.2 Local position setpoint	143
9886.7 - 9949.7 Local max. velocity	141	9966.4 Positioning lag error window	143
9886.8 - 9949.8 Max. deceleration source	141	9970.1 / 9970.2 / 9970.3 Speed precontrol gain	32
9886.9 - 9949.9 Local max. deceleration	141	9973.1 Power off limit value "Uz threshold for rapid mains control"	180
9950.1 Error end status	13	9977.1 Response error message word 0	88
9951.1 Effective minimum torque	6	9978.1 Response error message word 0	88
9951.2 Effective maximum torque	6	9979.1 Source error message word	88
9951.4 Time interval between base periods	80	9980.1 Speed	5
9961.1 / 9961.2 / 9961.3 Software limit switch negative	46	9982.1 Software activation	172
9962.1 / 9962.2 / 9962.3 Motor utilization prewarning threshold	49	9985.1 Torque	5
9963.1 Setpoint cycle control	125, 133, 142, 161	9985.1 User-defined unit torque	132, 134, 158
9964.1 Torque setpoint source	133	9987.1 / 9987.2 / 9987.3 Maximum current	37
9964.2 Local torque setpoint	133	9992.1 Sync jitter compensation CAN1	79
9965.1 Speed setpoint source	125	9993.1 Sync jitter compensation CAN2	79
9965.10 Abs. source torque limit Q3	128	9994.1 / 9994.2 / 9994.3 Integrator mode	34
		9995.1 / 9995.2 / 9995.3 Integrator initialization	35
		9996.1 / 9996.2 / 9996.3 Local integrator	35
		9998.1 Position mode	114
		9999.11 / 9999.12 / 9999.13 Relative position of the reference point	115

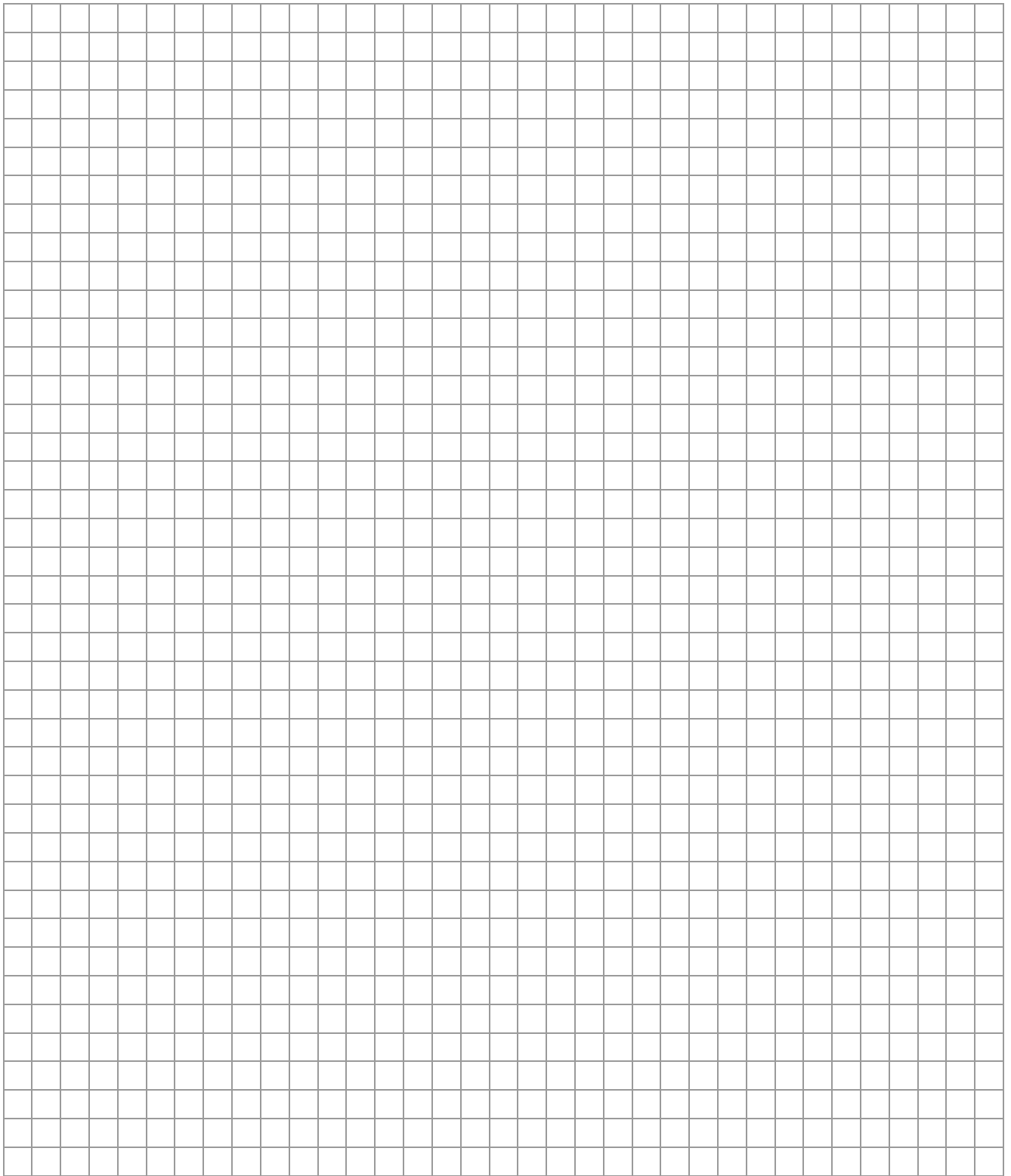



SEW-EURODRIVE
Driving the world

SEW
EURODRIVE

SEW-EURODRIVE GmbH & Co KG
P.O. Box 3023
D-76642 Bruchsal/Germany
Phone +49 7251 75-0
Fax +49 7251 75-1970
sew@sew-eurodrive.com

→ www.sew-eurodrive.com